

Rapier 48w Switch Installation and Safety Guide



Rapier 48w
Rapier 48w-B

Rapier 48w Switch **Installation and Safety Guide**

Rapier 48w
Rapier 48w-B

Download the complete document set from
www.alliedtelesis.com/support/software

Rapier 48w Switch Installation and Safety Guide
Document Number 613-000757 REV C

© 2007-2011 Allied Telesis, Inc. All rights reserved. No part of this publication may be reproduced without prior written permission from Allied Telesis, Inc.

Allied Telesis, Inc. reserves the right to change specifications and other information in this document without prior written notice. The information provided herein is subject to change without notice. In no event shall Allied Telesis, Inc. be liable for any incidental, special, indirect, or consequential damages whatsoever, including but not limited to lost profits, arising out of or related to this manual or the information contained herein, even if Allied Telesis, Inc. has been advised of, known, or should have known, the possibility of such damages.

All company names, logos, and product designs that are trademarks or registered trademarks are the property of their respective owners.

Contents

Switches Covered By This Guide	4
Package Contents	5
Selecting a Site	6
Installing the Switch	7
Applying Power to the Switch	10
Connecting Data Cables to the Switch	14
Configuring the Switch	16
Checking LEDs	18
Documentation Set	20
AC Model Standards	21
DC Model Standards	22
Safety	23
Sicherheit	24
Sikkerhed	26
Veiligheid	28
Sécurité	30
Turvallisuus	32
Norme di Sicurezza	33
Sikkerhet	35
Segurança	37
Seguridad	39
Säkerhet	41
Telecommunications Interfaces	42

Switches Covered By This Guide

This document includes information on the following switches:

- Rapier 48w (DC model)
- Rapier 48w-B (AC and DC models)

The Rapier 48w and 48w-B switches have the same features, however the physical connection between the switch and NSMs is different. The compatible NSMs for each model are:

- Rapier 48w: AT-AR040, AT-AR048
- Rapier 48w-B: AT-AR040-B, AT-AR048-B

In this guide, the product name Rapier 48w refers to both the Rapier 48w and the Rapier 48w-B models, except where an explicit reference is made.

You can download updates to this document from www.alliedtelesis.com/support/software.

NEBS Compliance

The Rapier 48w DC models meet Network Equipment Building System (NEBS) compliance under the following conditions:

- The switch is located in a network telecommunications facility.
- When rack-mounted, all bare conductors are coated with an appropriate antioxidant compound before making crimp connections.
- The supplied air filters are installed in both fan units.

For information about NEBS requirements when connecting cables to the switch, see “[Connecting Data Cables to the Switch](#)” on page 14.

The Rapier 48w AC model has not been tested for NEBS requirements.

Package Contents

These items are included with each Rapier 48w switch. Contact your authorised distributor or reseller if any items are damaged or missing.

AC model package contents

- one serial cable for connecting the switch to a terminal or PC
- one AC power cord
- two 19inch rack-mount brackets, two 23inch rack-mount brackets and eight M4 flat head screws, for mounting the switch in a rack
- this Installation and Safety Guide
- one CD-ROM with complete documentation and utilities
- one warranty card

DC model package contents

- one serial cable for connecting the switch to a terminal or PC
- two 19inch rack-mount brackets, two 23inch rack-mount brackets and eight M4 flat head screws, for mounting the switch in a rack
- one grounding stud crimp terminal
- two M5 hex nuts with lock washers for connecting the switch to primary ground
- one 4-terminal DC connector plug (MSTB) with fixing screws
- two air filters
- this Installation and Safety Guide
- one CD-ROM with complete documentation and utilities
- one warranty card

Selecting a Site

Before you install the switch, review the following considerations about its location.

- The Rapier 48w switch requires an ambient temperature from 0°C to 50°C (32°F to 122°F).
- There should be adequate front-to-back airflow around the switch and its vents.
- The site should be dust-free and without moisture.
- Humidity can be from 5% to 80% non-condensing.
- You need a reliable and earthed (grounded) power supply source, preferably dedicated and filtered.
- The switch ports are suitable for connection to intra-building or non-exposed cabling only (NEBS requirement)
- Cabling must not be exposed to sources of electrical noise, such as radio transmitters, broadband amplifiers, power lines, electric motors, and fluorescent fixtures.
- Related network devices can be connected to the switch but cannot exceed maximum cable lengths specified in the Hardware Reference.
- Ensure easy access to the switch's power and cable connections.
- You may need to remove cabinet doors to accommodate cords and cables.
- When rack mounted, the switch must be located evenly to prevent uneven mechanical loading of the rack.
- Rapier 48w DC models are NEBS compatible only when the switch is located in a network telecommunications facility.

Installing the Switch

You can install the switch on a level surface, such as a desktop or bench, in a standard 19-inch rack, or in a 23-inch rack.

The ports on the switch must not be metallicly connected to interfaces that connect to Outside Plant or its wiring (NEBS requirement).

Before you begin

- Read the safety information.

For your well-being and that of the equipment, read the safety information in this document. You can also download this document from www.alliedtelesis.com/support/software.

- Verify the package contents if you have not already done so.

See “[Package Contents](#)” on page 5. If any items are damaged or missing, contact your authorised distributor or reseller.

- Gather necessary tools and equipment.

For a **Rapier 48w AC** switch, you will need:

- a Phillips #2 screwdriver for fitting the rack-mount brackets
- four rack-mount screws and cage nuts (if required)

For a **Rapier 48w DC** switch, you will need:

- a Phillips #2 screwdriver for fitting the rack-mount brackets
- four rack-mount screws and cage nuts (if required)
- a flat screwdriver for the captive screws on the fan units and the DC power connection
- a suitable spanner for tightening the nuts on the chassis grounding stud
- an appropriate DC power source, DC supply cable, ring connectors, wire strippers, and a PANDUIT Uni-Die® dieless crimping toolset

- Prepare the cabinet in a suitable location

Follow guidelines described in “[Selecting a Site](#)” on page 6 to choose an appropriate location and modify the rack as necessary.

You can install the switch in a 19-inch rack, a 23-inch rack, or on a flat bench.

- If you have an optional Network Service Module (NSM), or Port Interface Cards (PICs), install them in the switch first.

For details, refer to the *Network Service Module Installation and Safety Guide* and the *Port Interface Card Installation and Safety Guide*. These guides are shipped with each NSM or PIC. You can also download them from www.alliedtelesis.com/support/software.

Rack-mount the switch

1. Ensure the rack has sufficient space for the switch and its cables. For the switch's requirements, see ["Selecting a Site"](#) on page 6.
2. Install cage nuts, if required, so they are ready for the rack-mount screws in the following steps. The Rapier 48w can be front, center, or rear mounted.
3. Unpack the switch.
4. Screw one bracket to each side of the switch using the M4 screws provided.

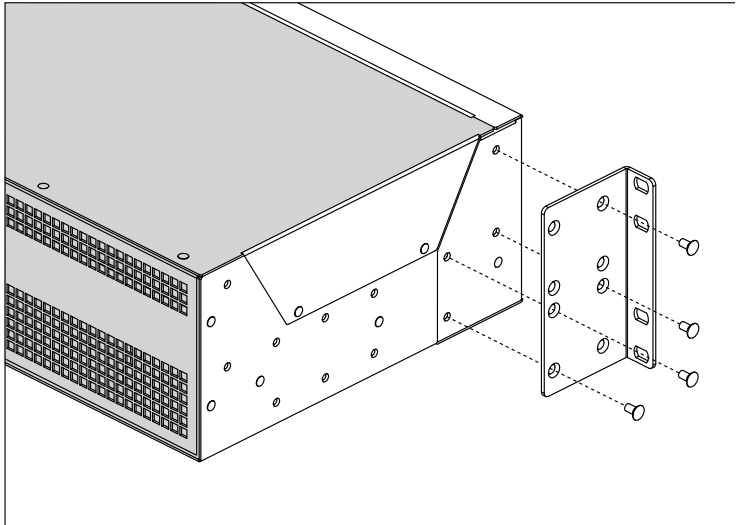

5. Mount the switch into the rack, and tighten the 4 rack-mount screws.

Install the air filters (NEBS installation only)

Rapier 48w DC switches are shipped with air filters that you must install in each of the fan units for Network Equipment Building System (NEBS) compliance.

To install an air filter:

1. Using a flat screwdriver, undo the captive screws on the front of the fan unit.
2. Slide the fan unit out of its cage. The internal power connection is quite solid, so pull firmly on the captive screws.
3. Insert the air filter into the narrow slot between the front grill of the fan unit and the fan. Position the air filter with the plastic frame towards the fan and the pull tab to the top. The air filter should fit snugly.

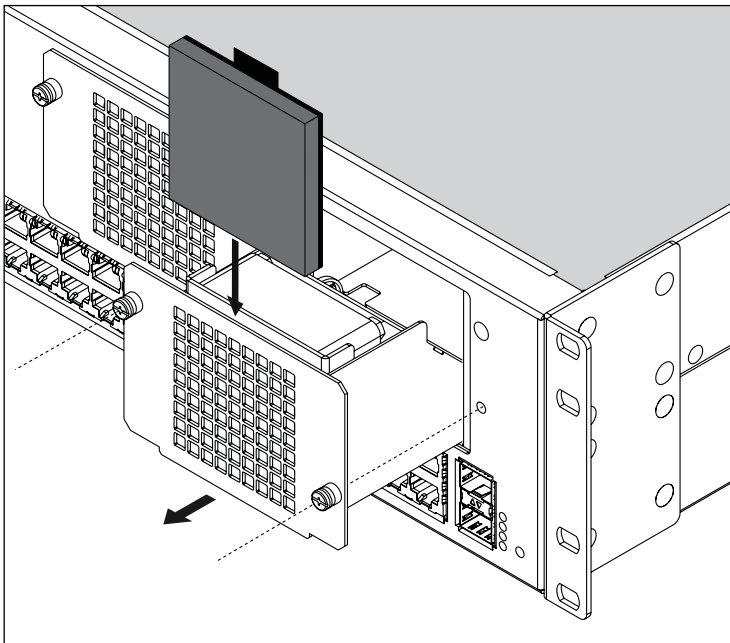

4. Slide the fan unit back into its cage, making sure that the air filter and the pull tab are clear of any contact points.
5. Press the fan unit firmly into place and tighten the captive screws on the front of the fan unit.

Applying Power to the Switch

The specific power supply requirements for the Rapier 48w are clearly displayed on the rear of the switch. If the supply is outside the accepted range for the switch, the switch may not operate or damage to the switch may result.



Warning All versions of this equipment must be earthed.

Rapier 48w AC switch

Follow these instructions when powering the AC switch variant.

1. Plug the provided AC power cord into the power inlet.
2. Connect the power cord to the main power source.
3. Check that the PSU LED on the front panel of the switch is lit green. If the LED does not light, refer to the Hardware Reference for troubleshooting information.

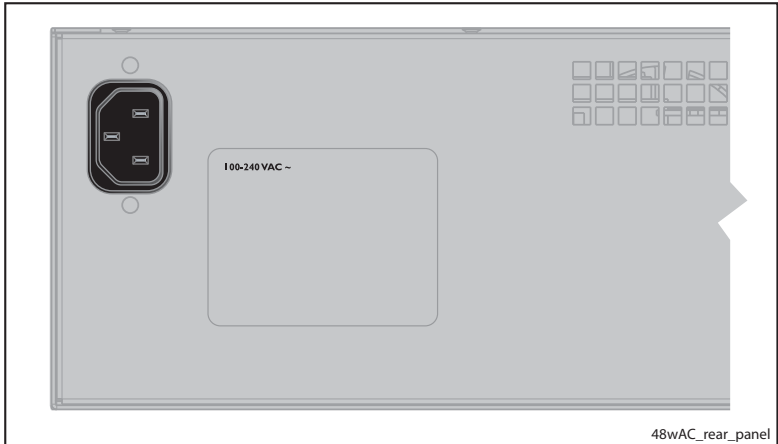

Rapier 48w DC switch

Follow these instructions when connecting the DC switch variant. Read “[Safety](#)” on [page 23](#) of this document before connecting a DC power supply.



Warning Only trained and qualified personnel should connect a DC power supply.

For centralised DC power connection, the switch should be installed in **restricted access areas only** (such as dedicated equipment rooms or equipment closets) in accordance with Articles 110-16, 110-17, and 110-18 of the National Electrical Code, ANSI/NFPA 70.

Damage to equipment may result if power is connected improperly.

Before working on equipment that is connected to power, remove jewellery including rings, necklaces, and watches. Metal objects will heat up when connected between power and ground, and can cause serious burns or weld the metal object to the terminals.

NEBS preparation when rack-mounted

To ensure rack-mounted installations are earthed for compatibility with NEBS, all bare conductors must be coated with an appropriate antioxidant compound before making crimp connections.

DC supply cable and power supply

Supply cable specifications:

- two-core cable is required
- minimum core size: 2.1mm² (14 AWG)
- minimum cable rating: 600 V, 90 degrees C

Power supply specifications:

- 48 VDC (40 to 60 VDC is acceptable)
- supports either positive grounded or negative grounded operation
- a 15Amp certified/listed circuit breaker is required for circuit protection

Connect the switch to ground

The protective earth connection should be connected before proceeding with the following power connections. The primary ground for the equipment is a two stud grounding block (bearing the grounding symbol) located on the left rear of the chassis, adjacent to the DC power connector.

To connect the switch to ground:

1. Using a 10AWG (5mm² cross sectional area) grounding cable (green with yellow stripe), connect the chassis grounding stud to the office primary ground using the two nuts with integral lock washers supplied. Tighten the nuts with an appropriate spanner.
2. Strip an 18mm (0.75 inch) length of insulation from the grounding cable and connect this to the grounding stud crimp terminal, using PANDUIT Uni-Die® dieless crimping toolset. Ensure that no stranded wires protrude from the terminal. The torque value for the chassis grounding studs is 2.57 Nm (22.8 lbf in).

Connect the DC supplies

To provide power supply resiliency, the Rapier 48w switch can receive its DC power from either of two separate sources. Each power source should supply 48V DC (40 to 60VDC) to the switch. When the switch is powered by centralized DC power, use UL Listed Type TC tray cables to connect the equipment to the power sources. Each tray cable should have two conductors in the range #14 to #12 AWG (2.0 to 2.5mm² cross sectional area), such as Belden No. 3081A.

Each DC branch circuit should connect to the Rapier switch via a 15A (maximum) circuit breaker or fuse that meets the requirements for branch circuit protection. The DC supply should be fed via a circuit breaker or switch capable of disconnecting power during servicing. The tray cable should be a UL Listed Type TC tray cable with two conductors in the range #14 to #12 AWG (2.0 to 2.5mm² cross sectional area), such as Belden No. 3081A.

To connect the DC supply:

1. Ensure that the DC power source is powered off during installation.
2. Strip 12mm (0.5 inches) of jacket material off the tray cable and strip 7mm (0.27 inches) of insulation off each individual wire.

3. Connect the A feed -48V wire to the screw terminal labelled “A -” on the rear panel of the switch, and use a flat screwdriver to tighten the screw to a torque of 0.5 to 0.8Nm (4.4 to 7.1 lbf in). Ensure no wire strands protrude from the terminal.

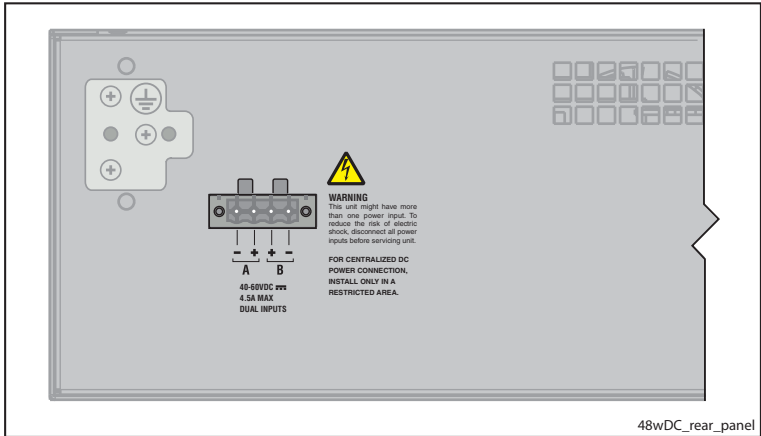

4. Connect the A feed 48V return wire to the screw terminal labelled “A +” on the rear panel of the switch, and use a flat screwdriver to tighten the screw to a torque of 0.5 to 0.8Nm (4.4 to 7.1 lbf in). Ensure no wire strands protrude from the terminal. Note that the DC return input terminal must be connected as Isolated DC return (DC-I).
5. Use the same procedure to connect an additional power source, if required, to the terminals labelled B.
6. Secure the tray cable near the rack framework using multiple cable ties to minimize the chance of the connections being disturbed by casual contact with wiring. Use at least four cable ties separated 10cm (4inches) apart with the first one located within 15cm (6inches) of the terminal block.
7. Energise the DC power source to the switch.
The Fault LED should light for approximately 3 seconds as the switch runs internal tests. If the LED remains lit, refer to the *Rapier Switch Hardware Reference* for troubleshooting information.
8. Check that the Power LED on the front panel lights green.
If the LED fails to light, refer to the *Rapier Switch Hardware Reference* for troubleshooting information.

Connecting Data Cables to the Switch

Once initial configuration is complete, connect the switch to the network.



Warning The Ethernet, DS3, T1, and management/asyn ports of the equipment are suitable for connection to intra-building or unexposed wiring or cabling only. These ports **must not** be metallically connected to interfaces that connect to the OSP or its wiring. These interfaces are designed for use as intra-building interfaces only (Type 2 or Type 4 ports as described in GR-1089-CORE, Issue 4) and require isolation from the exposed OSP cabling. The addition of Primary Protectors is not sufficient protection in order to connect these interfaces metallically to OSP wiring.

The management/asyn intra-building ports can only be directly connected to equipment within the same frame, cabinet or line-up and where the equipment is separated by a distance of 6m or less. The exception to this is when intra-building wiring (cabling) is used for maintenance purposes only and is not connected during normal operation.

Ethernet 10/100Mbps RJ-45 ports

Use either straight-through or cross-over twisted pair cables to connect network devices to the 10/100MB switch ports. The switch will autonegotiate the MDI/MDI-X polarity. Make sure that each cable connection is secure. The switch will now perform basic Layer 2 switching functions. By default, all switch ports are members of vlan 1.

Gigabit SFP ports

SFP ports 49 and 50 support optional gigabit copper and fibre SFP (Small Form-factor Pluggable) transceivers. For a list of supported SFPs, see the *Rapier Series Switch Hardware Reference*.



Warning Do not look into the optical ports of SFP cables or transceivers. Invisible laser radiation may be emitted from disconnected fibres or connectors.

The SFP transceiver must be inserted the right way in the slot:

- To install an SFP in port 49 (upper), the release lever hinge must be at the bottom.
- To install an SFP in port 50 (lower), the release lever hinge must be at the top.

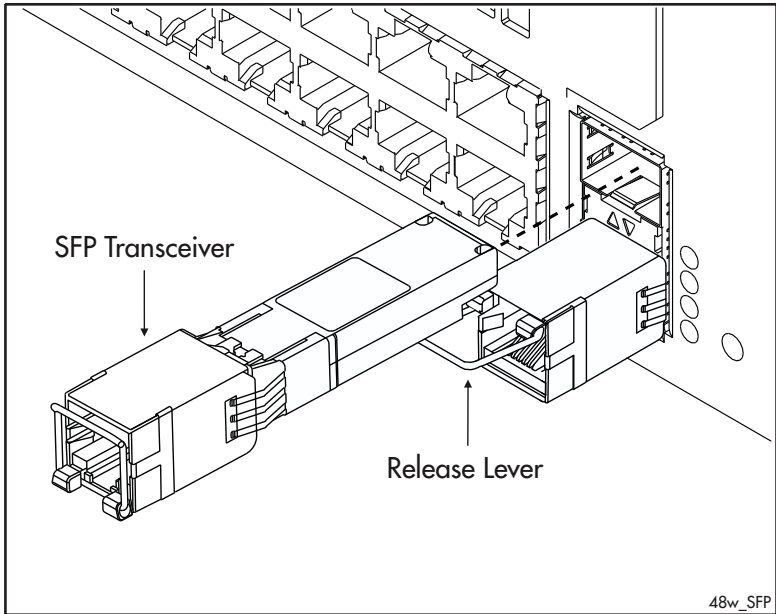

To insert an SFP transceiver, slide the transceiver into the SFP socket, and firmly press it until it engages. To remove an SFP transceiver, first release it by gently pulling the release lever, then pull it out of the socket. **Never** force a transceiver into or out of a socket.

WAN ports

If you have installed an NSM, connect the NSM ports to the WAN. For more information, see the *Network Service Module Installation and Safety Guide* and the *Network Service Module Hardware Reference*.

If you have installed an AR040 or AR040-B 4-PIC NSM with PICs, connect the PIC ports to the WAN. For more information, see the *Port Interface Card Installation and Safety Guide* and the *Port Interface Card Hardware Reference*.

Configuring the Switch

The Rapier 48w switch can be configured with the Command Line Interface (CLI). Before configuring the switch, you must make some basic connections explained in the following procedure. Before starting the procedure, ensure that the switch is installed and operating.

Using the CLI to configure the switch

1. Connect a terminal or PC to a console port.

The Rapier 48w has two identical asynchronous serial RS-232 console ports with DB9 connectors on the front panel, `asyn0` and `asyn1`. Using the supplied RS-232 straight-through cable, connect your terminal or PC to one of the console ports. For NEBS compatibility, the cable must be shielded and grounded at both ends, especially if permanently connected.

2. Set the communication parameters.

Set the communication parameters on your terminal or terminal emulation program to:

- Bit rate: 9600
- Data bits: 8
- Parity: None
- Stop bits: 1
- Flow control: Hardware

For information about terminal emulation, see *Using Windows Terminal and HyperTerminal* in the Hardware Reference.

3. Log in at the prompt.

After the switch has booted, the login prompt appears. If the login prompt does not appear, press the [Enter] key two or three times.

When the switch boots for the first time, it automatically creates an account with manager privileges. The login name for the account is *manager* and the password is *friend*.

At the login prompt, enter the login name and password as follows:

```
Login: manager
Password: friend
```

The command prompt is displayed after successful login. You can now use the CLI to configure the switch.

4. Change the password.

Change the password as soon as possible because a manager account with the default password is a serious security risk. Remember the new password because there is no way to retrieve it if you forget it.

To change the account password, use the **set password** command.

5. Configure the online help.

To use online help you must first configure the help file, by using the command:

```
set help=<filename>.hlp
```

Help files have a .hlp extension. To see a list of help files loaded on your switch, use the command:

```
show files=*.hlp
```

6. Configure the switch.

Refer to the Software Reference for more information about configuring the software. Alternatively, if you do not know the command syntax, use any of the following to help you:

- To display a list of help topics, use the **help** command.
- To display help on a specific topic, use the **help <topic>** command.
- To display a list of valid options, type a question mark or press the Tab key at the end of a partial command.
- To complete a parameter after you have typed enough letters to uniquely match the desired one, press the Tab key.

7. Save the configuration.

Save your configuration to a new file by using the command:

```
create config=<filename>.cfg
```

Then set the switch to load this file when it restarts by using the command:

```
set config=<filename>.cfg
```

Checking LEDs

The following tables describe how the switch and expansion modules report faults and operational activities. Expansion modules are optional and must be purchased separately. Contact your authorised Allied Telesis distributor or reseller, or visit www.alliedtelesis.com for more information on purchasing expansion modules.

Status LEDs

LED	State	Description
FAULT	Off	Switch operation is normal.
	Red	The switch or management software is malfunctioning.
	I flash	A switch fan has failed.
POWER	Green	The switch is receiving power and the voltage is within the acceptable range.
	Off	The switch is not receiving power.

NSM LEDs

LED	State	Description
SWAP	Green	The NSM and its PICs are ready to be hot swapped.
	Off	The Hot Swap button must be pressed before the NSM or its PICs can be hot swapped, or the software version does not support hot swapping.
IN USE	Green	The NSM is installed, is receiving power and is operational. The NSM and its PICs are NOT ready to be hot swapped.
	Off	No NSM is installed, or the NSM is not installed correctly (the switch unit has not recognised the NSM).

RJ-45 Port LEDs (Ports 1 - 48)

LED	State	Description
L/A	Green	100 M Link established
	Flashing	100 M Link activity
	Amber	10 M Link established
	Flashing	10 M Link activity
	Off	No link
D/C	Green	Full Duplex
	Flashing	N/A
	Amber	Half Duplex
	Flashing	Collisions
	Off	No link

SFP Port LEDs (Ports 49 - 50)

LED	State	Description
L/A	Green	1000 M Link established.
	Flashing	1000 M Link activity.
	Off	No link.
SFP	Amber	SFP installed.
	Flashing	SFP installed, but indicating a transmission fault.
	Off	No link.

Documentation Set

The complete document set for Rapier Series switches includes the following:

- This Installation and Safety Guide for the Rapier 48w switch
- The *Rapier 48w Switch Removable Fan Installation Guide*, which describes how to install AT-FAN04 fan-only modules (FOMs) in the Rapier 48w switch
- The *Rapier i Series Switch Safety and Statutory Information* booklet, which contains safety information for all Rapier switches except the Rapier 48w
- The *Rapier Series Switch Quick Install Guide*, which describes how to install all Rapier switches except the Rapier 48w
- The *Rapier Series Switch Hardware Reference*, which contains detailed information on the hardware features of all Rapier Series switches
- The *Rapier Series Switch AlliedWare™ Operating System Software Reference*, which contains detailed information on configuring the switch and its software
- The *Network Service Module Installation and Safety Guide*, which describes how to install a Network Service Module
- The *Network Service Module Hardware Reference*, which contains detailed information on the hardware features of Network Service Modules
- The *Port Interface Card Installation and Safety Guide*, which describes how to install a Port Interface Card
- The *Port Interface Card Hardware Reference*, which contains detailed information on the hardware features of Port Interface Cards
- The *Uplink Module Installation and Safety Guide*, which describes how to install an uplink module
- The *Uplink Module Hardware Reference*, which contains detailed information on the hardware features of uplink modules

You can download these documents and updates from www.alliedtelesis.com/support/software.

You need Adobe® Acrobat® Reader® to view, search, or print these documents. You can download it from www.adobe.com.

The Documentation Tools CD-ROM included with each Rapier 48w switch contains these documents, plus:

- AT-TFTP Server for Windows, for transferring files to and from the switch
- Supported MIBs
- How-To Notes, Microsoft® Visio® stencils and other resources

AC Model Standards

The Rapier 48w-B AC switch meets the following standards:

Category	Approval Agency and Requirement
Electrical Safety	UL60950-1 CAN/CSA-C22.2 No. 60950-1-03 EN60950-1 AS/NZS 60950.1 EN 60825-1 21 CFR 1040
Electromagnetic Compliance	FCC CFR47 Part 15 Class A EN55022 Class A VCCI Class A AS/NZS CISPR22 Class A EN61000-3-2/3 EN55024
WEEE	Meets requirements of Directive 2002/96/EC of the European Parliament and of the council of 27 January 2003
RoHS	Meets requirements of Directive 2002/96/EC of the European Parliament and of the council of 27 January 2003

U.S. Federal Communications Commission

RADIATED ENERGY

Note: This equipment has been tested and found to comply with the limits for a Class A digital device pursuant to Part 15 of the FCC Rules. These limits are designed to provide reasonable protection against harmful interference when the equipment is operated in a commercial environment. This equipment generates, uses, and can radiate radio frequency energy and, if not installed and used in accordance with this instruction manual, may cause harmful interference to radio communications.

Operation of this equipment in a residential area is likely to cause harmful interference in which case the user will be required to correct the interference at his own expense.

Note: Modifications or changes not expressly approved by the manufacturer or the FCC can void your right to operate this equipment.

Canadian Department of Communications

This Class A digital apparatus meets all requirements of the Canadian Interference-Causing Equipment Regulations.

Cet appareil numérique de la classe A respecte toutes les exigences du Règlement sur le matériel brouilleur du Canada.

この装置は、クラスA情報技術装置です。この装置を家庭環境で使用すると電波妨害を引き起こすことがあります。この場合には使用者が適切な対策を講ずるよう要求されることがあります。

VCCI- A

DC Model Standards

The DC models of the Rapier 48w and 48w-B switches meet the following standards:

Category	Approval Agency and Requirement
Electrical Safety	UL60950-1 CAN/CSA-C22.2 No. 60950-1-03 21 CFR 1040 EN60950-1 AS/NZS 60950.1 EN60825-1
Electromagnetic Compliance	FCC CFR47 Part 15 Class A
NEBS Level 3	GR-1089-Core Issue 4 GR-63-Core Issue 3
WEEE	Meets requirements of Directive 2002/96/EC of the European Parliament and of the council of 27 January 2003
RoHS	Meets requirements of Directive 2002/96/EC of the European Parliament and of the council of 27 January 2003

U.S. Federal Communications Commission

RADIATED ENERGY

Note: This equipment has been tested and found to comply with the limits for a Class A digital device pursuant to Part 15 of the FCC Rules. These limits are designed to provide reasonable protection against harmful interference when the equipment is operated in a commercial environment. This equipment generates, uses, and can radiate radio frequency energy and, if not installed and used in accordance with this instruction manual, may cause harmful interference to radio communications.

Operation of this equipment in a residential area is likely to cause harmful interference in which case the user will be required to correct the interference at his own expense.

Note: Modifications or changes not expressly approved by the manufacturer or the FCC can void your right to operate this equipment.

Canadian Department of Communications

This Class A digital apparatus meets all requirements of the Canadian Interference-Causing Equipment Regulations.

Cet appareil numérique de la classe A respecte toutes les exigences du Règlement sur le matériel brouilleur du Canada.

Safety



WARNING: In a domestic environment this product may cause radio interference in which case the user may be required to take adequate measures.



WARNING: Class I Laser product.



WARNING: Do not stare into the laser beam.



CAUTION: Use of controls or adjustments of performance or procedures other than those specified herein may result in hazardous radiation exposure.



ELECTRICAL NOTICES

WARNING: ELECTRIC SHOCK HAZARD

To prevent ELECTRIC shock, do not remove the cover. No user-serviceable parts inside. This unit contains HAZARDOUS VOLTAGES and should only be opened by a trained and qualified technician.



LIGHTNING DANGER

DANGER: DO NOT WORK on equipment or CABLES during periods of LIGHTNING ACTIVITY.



CAUTION: POWER CORD IS USED AS A DISCONNECTION DEVICE. TO DE-ENERGIZE EQUIPMENT, disconnect the power cord.



ELECTRICAL - TYPE CLASS I EQUIPMENT

THIS EQUIPMENT MUST BE EARTHED. Power plug must be connected to a properly wired earth ground socket outlet. An improperly wired socket outlet could place hazardous voltages on accessible metal parts.



PLUGGABLE EQUIPMENT, the socket outlet shall be installed near the equipment and shall be easily accessible.



CAUTION: Air vents must not be blocked and must have free access to the room ambient air for cooling.



OPERATING TEMPERATURE: This product is designed for a maximum ambient temperature of 50 degrees C.



ELECTRICAL - AC MAINS CIRCUIT OVERLOADING

When installing product, consideration must be given to the accumulative nameplate ratings when connecting the equipment to the AC supply wiring.



CAUTION: MECHANICAL LOADING - Mounting of the equipment in the rack should be such that a hazardous condition is not achieved due to uneven loading.



Lithium Battery - Should only be changed by authorised service personnel.

CAUTION: Danger of explosion if battery incorrectly replaced. Replace only with Lithium Battery, type CR2032, and dispose of in accordance with the manufacturer's recommendations and all local codes.



ALL COUNTRIES: Install product in accordance with local and National Electrical Codes.



WARNING: For centralized DC power connection, install only in a restricted access area.



WARNING: Only trained and qualified personnel are allowed to install or replace this equipment.



WARNING: As a safety precaution, a 15 Amp circuit breaker should be installed at the supply end of the cable to be used with this LAN equipment.

Always connect the wiring to the LAN equipment first before connecting the wiring to the breaker. To avoid the danger of physical injury from electrical shock, do not work with HOT feeds. Always be sure that the breaker is in the Off position before connecting the wiring to the breaker.



WARNING: Do not strip more than the recommended amount of wire. Stripping more than the recommended amount can create a safety hazard by leaving exposed wire on the terminal block after installation.



WARNING: When installing this equipment, always ensure that the frame ground connection is installed first and disconnected last.



WARNING: "Safety Hazard" - Check to see if there are any exposed copper strands coming from the installed wires. When this installation is done correctly, there should be no exposed copper wire strands extending from the terminal block. Any exposed wiring can conduct harmful levels of electricity to persons touching the wires.



DC versions of this system will work with a positive grounded or negative grounded DC system.

Sicherheit



WARNUNG: Bei Verwendung zu Hause kann dieses Produkt Funkstörungen hervorrufen. In diesem Fall müßte der Anwender angemessene Gegenmaßnahmen ergreifen.



WARNUNG Laserprodukt der Klasse I.



WARNUNG Nicht direkt in den Strahl blicken.



ACHTUNG: GEFÄHRLICHE SPANNUNG

Das Gehäuse nicht öffnen. Das Gerät enthält keine vom Benutzer wartbaren Teile. Das Gerät steht unter Hochspannung und darf nur von qualifiziertem technischem Personal geöffnet werden.



GEFAHR DURCH BLITZSCHLAG

GEFAHR: Keine Arbeiten am Gerät oder an den Kabeln während eines Gewitters ausführen.



VORSICHT: DAS NETZKABEL DIENST ZUM TRENNEN DER STROMVERSORGUNG. ZUR TRENNUNG VOM NETZ, KABEL AUS DER STECKDOSE ZIEHEN.



GERÄTE DER KLASSE I

DIESE GERÄTE MÜSSEN GEERDET SEIN. Der Netzstecker darf nur mit einer vorschriftsmäßig geerdeten Steckdose verbunden werden. Ein unvorschriftsmäßiger Anschluß kann die Metallteile des Gehäuses unter gefährliche elektrische Spannungen setzen.



STECKBARES GERÄT: Die Anschlußbuchse sollte in der Nähe der Einrichtung angebracht werden und leicht zugänglich sein.”



VORSICHT

Die Entlüftungsöffnungen dürfen nicht versperrt sein und müssen zum Kühlen freien Zugang zur Raumluft haben.



BETRIEBSTEMPERATUR: Dieses Produkt wurde für den Betrieb in einer Umgebungstemperatur von nicht mehr als 50° C entworfen.



NETZSICHERUNG

Bei der Installation muß der auf dem Typenschild angezeigte Nennwert des Gerätes für den Anschluß an das Netz beachtet werden.



VORSICHT: RAHMENEINBAU

Die Geräte müssen so in den Rahmen montiert werden, daß keine Gefahren durch unebenen inbau des Rahmens verursacht werden.



Lithium-Batterie - Sollte nur von einem geschulten qualifizierten Techniker ausgetauscht werden.

VORSICHT: Explosionsgefahr bei unsachgemäßem Austausch der Batterie. Nur mit einer gleichen Batterie oder einem gleichwertigen Batterietyp nach Empfehlung des Herstellers ersetzen. Gebrauchte Batterien nach Anweisungen des Herstellers beseitigen.



ALLE LÄNDER: Installation muß örtlichen und nationalen elektrischen Vorschriften entsprechen.



Warnung: Bei zentralisierten gleichstromverbindungen sollte die installation nur an einem standort mit beschränktem zugang erfolgen.



Warnung: INSTALLATION UND WARTUNG DIESER EINRICHTUNG NUR DURCH AUSGEBILDETES FACHPERSONAL.



Warnung: Aus Sicherheitsgründen sollte am Netzteilende des mit dieser LAN-Einrichtung verwendeten Kabels ein 15-Ampere-Leistungsschalter installiert werden.

Nehmen Sie STETS zuerst die Verkabelung der LAN-Einrichtung vor, bevor Sie die Kabel an den Leistungsschalter anschließen. Arbeiten Sie nie mit SPANNUNGSFÜHRENDEN Kabeln, um Körperverletzungen durch Stromschlag zu vermeiden. Achten Sie stets darauf, daß sich der Leistungsschalter in der Position Off (Aus) befindet, bevor Sie Kabel an den Leistungsschalter anschließen.



Warnung: Ziehen Sie nicht mehr als die empfohlene Drahtlänge ab. Wird mehr als die empfohlene Länge abisoliert, stellt dies ein Sicherheitsrisiko dar, da auf dem Anschlußklemmblock nach der Installation möglicherweise freiliegende Drähte verbleiben.



Warnung: Bei der Installation dieser Einrichtung ist stets sicherzustellen, daß der Masseanschluß jeweils zuerst installiert und zuletzt getrennt wird.



Warnung: "Sicherheitsrisiko" Prüfen Sie, daß aus dem installierten Draht keine freiliegenden Kupferlitzen herausragen. Bei korrekter Installation sollten aus dem Anschlußklemmblock keine freiliegenden Kupferlitzen vorstehen. Freiliegende Kabel führen genug Spannung, um Personen zu gefährden, die diese Drähte berühren.



Hinweis: Dieses System kann mit positiv geerdeten oder negativ geerdeten Gleichstromsystemen betrieben werden.

Sikkerhed



ADVARSEL: I et hjemligt miljø kunne dette produkt forårsage radio forstyrrelse. Bliver det tilfældet, påkræves brugeren muligvis at tage tilstrækkelige foranstaltninger.



ADVARSEL Laserprodukt av klasse I.



ADVARSEL Stirr ikke på strålen.



ELEKTRISKE FORHOLDSREGLER

ADVARSEL: RISIKO FOR ELEKTRISK STØD

For at forebygge ELEKTRISK stød, undlad at åbne apparatet. Der er ingen indre dele, der kan repareres af brugeren. Denne enhed indeholder LIVSFARLIGE STRØMSPÆNDINGER og bør kun åbnes af en uddannet og kvalificeret tekniker.



FARE UNDER UVEJR

FARE: UNDLAD at arbejde på udstyr eller KABLER i perioder med LYNAKTIVITET.



ADVARSEL: DEN STRØMFØRENDE LEDNING BRUGES TIL AT AFBRYDE STRØMMEN. SKAL STRØMMEN TIL APPARATET AFBRYDES, tages ledningen ud af stikket.



ELEKTRISK - KLASSE I-UDSTYR

DETTE UDSTYR KRÆVER JORDFORBINDELSE. Stikket skal være forbundet med en korrekt installeret jordforbunden stikkontakt. En ukorrekt installeret stikkontakt kan sætte livsfarlig spænding til tilgængelige metaldele.



UDSTYR TIL STIKKONTAKT, stikkontakten bør installeres nær ved udstyret og skal være lettilgængelig.



ADVARSEL: Ventilationsåbninger må ikke blokeres og skal have fri adgang til den omgivende luft i rummet for afkøling.



BETJENINGSTEMPERATUR: Dette apparat er konstrueret til en omgivende temperatur på maksimum 50 grader C.



ELEKTRISK-OVERBELASTNING AF SPÆNDINGSKREDSLØBET

Ved installation af produktet, bør der tages hensyn til den kumulative kapacitet der angives på navneskiltet, når udstyret forbindes med vekselstrømsledningen.



ADVARSEL: MEKANISK OPSTILLING-Udstyret skal opstilles i stativet, på en sådan måde, at der ikke opstår fare p.g.a. ujævn opstilling.



Lithium batteri - Bør kun udskiftes af uddannet og kvalificeret tekniker.

ADVARSEL : Eksplosionsfare, hvis batteriet udskiftes ukorrekt. Udskift kun med samme eller en tilsvarende type der anbefales af producenten. Kassér brugte batterier i overensstemmelse med producentens instruktioner.



ALLE LANDE: Installation af produktet skal ske i overensstemmelse med lokal og national lovgivning for elektriske installationer.



Advarsel: ETABLERES FORBINDELSEN TIL ET JÆVNSTRØMSNET, BØR INSTALLERING FORETAGES I ET OMRÅDE HVOR UVEDKOMMENDE IKKE HAR ADGANG.



Advarsel: INSTALLERING OG UDSKIFTNING AF DETTE UDSTYR BØR KUN UDFØRES AF AUT. EL-INSTALLATØR.



Advarsel: Der bør indskydes en 15 A automatsikring på forsyningsenden af kablet til dette LAN-udstyr.

Man skal **ALTID** først forbinde ledningerne med LAN-udstyret inden de forbindes med automatsikringen. Ved ledningsarbejde skal strømmen altid være AFBRUDT til forebyggelse af fare for elektrisk stød. Man skal altid SLUKKE automatsikringen inden man forbinder ledninger med den.



Advarsel: Man bør ikke afisolere mere af ledningerne end anvist, for så kan sådanne blanke ledninger udgøre et faremoment efter montering på klemmerækken.



Advarsel: Ved installering af dette udstyr skal steljord altid forbindes først og aftages sidst.



Advarsel: “Fare” Se omhyggeligt efter om der stikker blanke kobbertråde ud fra klemmeforbindelserne. Ved korrekt montering er det ikke tilfældet. Enhver afisoleret leder kan lede farlig strømstyrke til personer, som kommer til at røre ved dem.



Bemærk: Dette udstyr kan køre både på jævnstrøm med positiv og med negativ jord.

Veiligheid



WAARSCHUWING: Binnenshuis kan dit product radiostoring veroorzaken, in welk geval de gebruiker verplicht kan worden om gepaste maatregelen te nemen.



WAARSHUWING Klasse-I laser produkt.



WAARCHUWING Neit in de straal staren.



WAARSCHUWINGEN MET BETREKKING TOT ELEKTRICITEIT

WAARSCHUWING: GEVAAR VOOR ELEKTRISCHE SCHOKKEN

Verwijder het deksel niet, teneinde ELEKTRISCHE schokken te voorkomen. Binnenin bevinden zich geen onderdelen die door de gebruiker onderhouden kunnen worden. Dit toestel staat onder GEVAARLIJKE SPANNING en mag alleen worden geopend door een daartoe opgeleide en bevoegde technicus.



GEVAAR VOOR BLIKSEMINSLAG

GEVAAR: NIET aan toestellen of KABELS WERKEN bij BLIKSEM.



WAARSCHUWING: HET TOESTEL WORDT UITGESCHAKELD DOOR DE STROOMKABEL TE ONTKOPPELEN. OM HET TOESTEL STROOMLOOS TE MAKEN: de stroomkabel ontkoppelen.



ELEKTRISCHE TOESTELLEN VAN KLASSE I
DIT TOESTEL MOET GEAARD WORDEN. De stekker moet aangesloten zijn op een juist geaarde contactdoos. Een onjuist geaarde contactdoos kan de metalen onderdelen waarmee de gebruiker eventueel in aanraking komt onder gevaarlijke spanning stellen.



AAN TE SLUITEN APPARATUUR, de contactdoos wordt in de nabijheid van de apparatuur geïnstalleerd en is gemakkelijk te bereiken.”



OPGELET: De ventilatiegaten mogen niet worden gesperd en moeten de omgevingslucht ongehinderd toelaten voor afkoeling.



BEDRIJFSTEMPERATUUR: De omgevingstemperatuur voor dit produkt mag niet meer bedragen dan 50 graden Celsius.



ELEKTRISCH: OVERBELASTING VAN WISSELSTROOM HOOFDCIRCUIT

Tijdens de installatie van het produkt dient men rekening te houden met de gecombineerde waarden op de naamplaatjes bij het aansluiten van het toestel op de wisselstroom-voedingsdraden.



OPGELET: MECHANISCH LADEN - De montage van het toestel in het rek dient zo uitgevoerd te worden dat geen gevaar ontstaat door een ongelijke lading.



Lithium batterij. Mag alleen worden vervangen door een daartoe opgeleide en bevoegde technicus.

OPGELET: Gevaar voor ontploffing indien de batterij verkeerd wordt vervangen. Alleen vervangen door hetzelfde of een gelijkwaardig, door de fabrikant aanbevolen type.



ALLE LANDEN: het toestel installeren overeenkomstig de lokale en nationale elektrische voorschriften.



Waarschuwing: Bij GECENTRALISEERDE DC-AANSLUITING: INSTALLATIE UITSLUITEND UITVOEREN IN EEN GEBIED MET BEPERKTE TOEGANG.



Waarschuwing: ALLEEN GESCHOOLD EN GEKWALIFICEERD PERSONEEL MAG DEZE APPARATUUR INSTALLEREN OF VERVANGEN.



Waarschuwing: Op de kabel die op de LAN-apparatuur wordt aangesloten dient een zekering van 15 amp te worden gemonteerd aan de zijde van de aansluiting op de voeding.

Sluit bedrading **ALTIJD** eerst op de LAN-apparatuur aan en pas daarna op de zekering. Voorkom het risico op een elektrische schok en schakel eerst de voeding uit. Controleer voordat u de bedrading op de zekering aansluit altijd of de zekering zich in de stand UIT bevindt.



Waarschuwing: Verwijder niet meer dan de aanbevolen hoeveelheid isolatiemateriaal. Als u meer dan de aanbevolen hoeveelheid verwijdert, kan dit een veiligheidsrisico veroorzaken doordat draden bloot blijven liggen na aansluiting op het blok.



Waarschuwing: Zorg er tijdens installatie van de apparatuur altijd voor dat de aardeaansluiting van het frame als eerste wordt geplaatst en als laatste wordt losgemaakt.



Waarschuwing: "Veiligheidsrisico" Controleer of er bij de aangesloten bedrading geen koper blootligt. Als de installatie juist is uitgevoerd, is er bij het aansluitblok geen koperdraad zichtbaar. Blootliggende bedrading kan schadelijke elektriciteitsniveaus geleiden naar personen die met de draden in aanraking komen.



Opmerking: Dit systeem werkt met positief geaarde of negatief geaarde DC-systemen.

Sécurité



MISE EN GARDE : dans un environnement domestique, ce produit peut provoquer des interférences radioélectriques. Auquel cas, l'utilisateur devra prendre les mesures adéquates.



ATTENTION Produit laser de classe I.



ATTENTION Ne pas fixer le faisceau des yeux.



INFORMATION SUR LES RISQUES ÉLECTRIQUES

AVERTISSEMENT: DANGER D'ÉLECTROCUTION

Pour éviter toute ÉLECTROCUTION, ne pas ôter le revêtement protecteur du matériel. Ce matériel ne contient aucun élément réparable par l'utilisateur. Il comprend des TENSIONS DANGEREUSES et ne doit être ouvert que par un technicien dûment qualifié.



DANGER DE Foudre

DANGER: NE PAS MANIER le matériel ou les CÂBLES lors d'activité orageuse.



ATTENTION: LE CORDON D'ALIMENTATION SERT DE MISE HORS CIRCUIT. POUR COUPER L'ALIMENTATION DU MATÉRIEL, débrancher le cordon.



ÉQUIPEMENT DE CLASSE I ÉLECTRIQUE

CE MATÉRIEL DOIT ÊTRE MIS À LA TERRE. La prise de courant doit être branchée dans une prise femelle correctement mise à la terre car des tensions dangereuses risqueraient d'atteindre les pièces métalliques accessibles à l'utilisateur.



EQUIPEMENT POUR BRANCHEMENT ÉLECTRIQUE, la prise de sortie doit être placée près de l'équipement et facilement accessible".



ATTENTION: Ne pas bloquer les fentes d'aération, ceci empêcherait l'air ambiant de circuler librement pour le refroidissement.



TEMPÉRATURE DE FONCTIONNEMENT: Ce matériel est capable de tolérer une température ambiante maximum de ou 50 degrés Celsius.



SURCHARGE DES CIRCUITS PRINCIPAUX DE COURANT ALTERNATIF ÉLECTRIQUE

Lors de l'installation du matériel, il faut prendre en compte la somme des puissances indiquées sur les étiquettes au moment de connecter le matériel à une source de courant alternatif.



ATTENTION : RÉPARTITION DE LA CHARGE MÉCANIQUE - Le montage du matériel dans le bâti doit être effectué de telle manière que la répartition de la charge mécanique ne pose aucun danger.



Pile en Lithium-Doit uniquement être remplacée par un technicien dûment qualifié

ATTENTION : Un danger d'explosion existe en cas de remplacement incorrect de la pile. Remplacer uniquement avec une pile du même type ou d'un type recommandé par le fabricant. Mettre au rebut les piles usagées conformément aux instructions du fabricant).



POUR TOUS PAYS: Installer le matériel conformément aux normes électriques nationales et locales.



Avertissement: POUR UNE CONNEXION A UNE SOURCE D'ALIMENTATION C.C. CENTRALISEE, L'INSTALLATION DOIT ETRE UNIQUEMENT EFFECTUEE DANS UNE ZONE D'ACCES LIMITE.



Avertissement: SEUL UN PERSONNEL QUALIFIE ET ENTRAINE EST AUTORISE A INSTALLER OU REMPLACER CET EQUIPEMENT.



Avertissement: Par mesure de sécurité, un disjoncteur de 15 A doit être installé au point d'alimentation électrique du câble devant être utilisé avec cet équipement de réseau local (LAN).

Connectez **TOUJOURS** le câblage à l'équipement LAN avant de le connecter au disjoncteur. Pour éviter tout risque de blessure corporelle par électrocution, ne travaillez pas lorsque le matériel est sous tension. Assurez-vous toujours que le disjoncteur est bien en position d'ARRET avant de le connecter au câblage.



Avertissement: Ne coupez pas une quantité de câble supérieure à celle qui est recommandée. Cela pourrait constituer un risque de sécurité en laissant du câblage à nu sur le bornier après l'installation.



Avertissement: Lors de l'installation de cet équipement, vérifiez toujours que la connexion de terre du châssis est installée en premier et débranchée en dernier.



Avertissement: “Risque de sécurité” Vérifiez qu'aucun fil de cuivre dénudé ne sort du câble installé. Lorsque cette installation est effectuée correctement, aucun fil de cuivre ne devrait dépasser du bornier. Tout câblage dénudé peut être conducteur de tensions dangereuses pour les personnes touchant les câbles.



Remarque: Ce système peut fonctionner avec des systèmes C.C. dotés d'une mise à la terre positive ou négative.

Turvallisuus



VAROITUS: Kotiolosuhteissa tämä laite voi aiheuttaa radioaaltojen häiröitä, missä tapauksessa laitteen käyttäjän on mahdollisesti ryhdyttävä tarpeellisiin toimenpiteisiin.



VAROITUS Luokan I Lasertuote.



VAROITUS Älä katso säteeseen.



SÄHKÖÖN LIITTYVIÄ HUOMAUTUKSIA

VAROITUS: SÄHKÖISKUVAARA

Estääksesi SÄHKÖISKUN älä poista kantta. Sisällä ei ole käyttäjän huollettavissa olevia osia. Tämä laite sisältää VAARALLISIA JÄNNITTEITÄ ja sen voi avata vain koulutettu ja pätevä teknikko.



SALAMANISKUVAARA

HENGENVAARA: ÄLÄ TYÖSKENTELE laitteiden tai KAAPELEIDEN KANSSA SALAMOINNIN AIKANA.



HUOMAUTUS: VIRTAJOHTOA KÄYTETÄÄN

VIRRANKATKAISULAITTEENA. VIRTA KATKAISTAAN irrottamalla virtajohto.



SÄHKÖ - TYYPPILUOKAN I LAITTEET

TÄMÄ LAITE TÄYTY MAADOITTA. Pistoke täytyy liittää kunnollisesti maadoitettuun pistorasiaan. Virheellisesti johdotettu pistorasia voi altistaa metalliosat vaarallisille jännitteille.



PISTORASIAAN KYTKETTÄVÄ LAITE; pistorasia on asennettava laitteen lähelle ja siihen on oltava esteetön pääsy.”



HUOMAUTUS: Ilmavaihtoreikiä ei pidä tukkia ja niillä täytyy olla vapaa yhteys ympäröivään huoneilmaan, jotta ilmanvaihto tapahtuisi.



KÄYTTÖLÄMPÖTILA: Tämä tuote on suunniteltu ympäröivän ilman maksimilämpötilalle 50°C.



SÄHKÖ-VAIHTORVIRTASÄHKÖPIIRIN YLIKUORMITUS

Tuotetta asennettaessa on otettava huomioon osien nimikilvissä osoitettu teho silloin kun osat liitetetään vaihtovirtaverkkoon.



HUOMAUTUS: MEKAANINEN KUORMITUS--Osien asennuksen alustaan tulee tapahtua siten, että epätasainen kuormitus ei aiheuta vaaraa.



Litiumparisto - Vaihdon voi suorittaa vain koulutettu ja pätevä teknikko.

Varoitus: Räjähdyksivaara, jos paristo on vaihdettu väärin. Vaihda vain samaan tai vastaavaan tyyppiin, jota valmistaja suosittelee. Hävitä käytetyt paristot valmistajan ohjeiden mukaan.



KAIKKI MAAT: Asenna tuote paikallisten ja kansallisten sähköturvallisuusmääräysten mukaisesti.



Varoitus: KESKITETTY TASAVIRTAKYTKENTÄ ASENNETTAVA AINOASTAAN TILAAN, JOHON ON RAJOITETTU PÄÄSY.



Varoitus: TÄMÄN LAITTEEN SAA ASENTAA TAI VAIHTAA AINOASTAAN KOULUTETTU JA AMMATTITAITOINEN HENKILÖKUNTA.



Varoitus: Tämän LAN-laitteen kanssa käytettävän kaapelin syöttöpäähän tulee turvallisuuksista asentaa 15 A virrankatkaisin.

Yhdistä johdot AINA ensin LAN-laitteeseen ennen virrankatkaisimeen kytkemistä. Sähköiskusta johtuvien vammojen välttämiseksi älä käsittele JÄNNITTEELLISIÄ johtoja. Varmista aina, että virrankatkaisin on pois päältä (off) ennen kuin yhdistät johdot katkaisimeen.



Varoitus: Älä poista johtimesta päällystettä enempiä kuin on suositeltu. Päällysteen poistaminen suositusta pidemmältä matkalta voi aiheuttaa turvallisuusrisikin, sillä riviliittimeen jää asennuksen jälkeen paljaita johtimia.



Varoitus: Kun asennat tätä laitetta, varmista aina, että runkomaadoitettu liitin kytketään ensin ja irrotetaan viimeiseksi.



Varoitus: Turvallisuusriski Tarkista, ettei asennetusta johtimesta näy paljaita kuparisäikeitä. Kun asennus suoritetaan oikein, riviliittimestä ei pitäisi näkyä paljaita kuparijohdinsäikeitä. Paljaat johtimet voivat aiheuttaa sähköiskuvaaran, jos niihin kosketaan.



Huomaa: Tämä järjestelmä toimii positiivisesti tai negatiivisesti maadoitettujen tasavirtajärjestelmien kanssa.

Norme di Sicurezza



AVVERTENZA: in ambiente domestico questo prodotto potrebbe causare radio interferenza. In questo caso potrebbe richiedersi all'utente di prendere gli adeguati provvedimenti.



AVVERTENZA Prodotto laser di Classe I.



AVVERTENZA Non fissare il raggio con gli occhi.



AVVERTENZE ELETTRICHE

ATTENZIONE: PERICOLO DI SCOSSE ELETTRICHE

Per evitare SCOSSE ELETTRICHE non asportare il coperchio. Le componenti interne non sono riparabili dall'utente. Questa unità ha TENSIONI PERICOLOSE e va aperta solamente da un tecnico specializzato e qualificato.



PERICOLO DI FULMINI

PERICOLO: NON LAVORARE sul dispositivo o sui CAVI durante PRECIPITAZIONI TEMPORALESCHIE.



ATTENZIONE: IL CAVO DI ALIMENTAZIONE È USATO COME DISPOSITIVO DI DISATTIVAZIONE. PER TOGLIERE LA CORRENTE AL DISPOSITIVO staccare il cavo di alimentazione.



ELETTRICITÀ - DISPOSITIVI DI CLASSE I
QUESTO DISPOSITIVO DEVE AVERE LA MESSA A TERRA. La spina deve essere inserita in una presa di corrente specificamente dotata di messa a terra. Una presa non cablata in maniera corretta rischia di scaricare una tensione pericolosa su parti metalliche accessibili.



APPARECCHIATURA COLLEGABILE, la presa va installata vicino all'apparecchio per risultare facilmente accessibile”.



ATTENZIONE: le prese d'aria non vanno ostruite e devono consentire il libero ricircolo dell'aria ambiente per il raffreddamento.



TEMPERATURA DI FUNZIONAMENTO: Questo prodotto è concepito per una temperatura ambientale massima di 50 gradi centigradi.



ELETTRICITÀ - SOVRACCARICO DEL CIRCUITO DI RETE A C.A.
Durante l'installazione ed il collegamento del dispositivo alla rete di alimentazione a corrente alternata, è necessario tenere in considerazione le capacità cumulative riportate sulla targhetta.



ATTENZIONE: CARICAMENTO MECCANICO - Il montaggio del dispositivo sul supporto va effettuato in maniera tale da evitare qualsiasi potenziale condizione di pericolo eventualmente dovuta al montaggio irregolare.



Batteria al litio - Va sostituita solo da un tecnico specializzato e qualificato.
ATTENZIONE: l'errata sostituzione della batteria può causare pericolo di esplosioni. Sostituire solamente con lo stesso tipo o con uno equivalente raccomandato dal produttore. Eliminare le batterie usate secondo le istruzioni del produttore.



TUTTI I PAESI: installare il prodotto in conformità delle vigenti normative elettriche nazionali.



Avvertenza: AI FINI DEL COLLEGAMENTO CENTRALIZZATO DI ALIMENTAZIONE A CC, INSTALLARE SOLO IN UN'AREA AD ACCESSO LIMITATO.



Avvertenza: L'INSTALLAZIONE E LA SOSTITUZIONE DI QUESTA APPARECCHIATURA DEVONO ESSERE EFFETTUATE SOLAMENTE DA PERSONALE SPECIALIZZATO E QUALIFICATO.



Avvertenza: A titolo di cautelativo, installare un interruttore di sicurezza da 15 ampere sull'estremità in entrata del cavo di alimentazione di questa apparecchiatura LAN.

Collegare **SEMPRE il cablaggio** prima all'apparecchiatura LAN e poi all'interruttore. Per evitare i infortuni causati da folgorazione, non lavorare su

cavi SOTTO TENSIONE. Prima di collegare il cavo all'interruttore di sicurezza, accertarsi sempre che quest'ultimo sia disinserito.



Avvertenza: Per evitare i possibili pericoli associati all'esposizione dei fili sulla morsettiere dopo l'installazione, non rimuovere l'isolamento oltre le misure specificate.



Avvertenza: Quando si installa questo apparecchio, accertarsi sempre che il collegamento a massa del telaio sia sempre il primo ad essere effettuato e l'ultimo ad essere scollegato.



Avvertenza: "Pericolo!" Controllare che il filo installato non abbia trefoli in rame esposti. Se l'installazione è stata effettuata in modo corretto, non vi deve protrudere dalla morsettiere alcun trefolo in rame esposto. In caso di contatto, un filo esposto può condurre livelli di elettricità pericolosi a quanti lo tocchino.



Nota: Questo sistema funziona con sistemi a CC con massa positiva o negativa.

Sikkerhet



ADVARSEL: Hvis dette produktet benyttes til privat bruk, kan produktet forårsake radioforstyrrelse. Hvis dette skjer, må brukeren ta de nødvendige forholdsregler.



ADVARSEL Laserprodukt av klasse I.



ADVARSEL Stirr ikke på strålen.



ELEKTRISITET

ADVARSEL: FARE FOR ELEKTRISK SJOKK

For å unngå ELEKTRISK sjokk, må dekslet ikke tas av. Det finnes ingen deler som brukeren kan reparere på innsiden. Denne enheten inneholder FARLIGE SPENNINGER, og må kun åpnes av en faglig kvalifisert tekniker.



FARE FOR LYNNEDSLAG

FARE: ARBEID IKKE på utstyr eller KABLER i TORDENVÆR.



FORSIKTIG: STRØMLEDNINGEN BRUKES TIL Å FRAKOBLE UTSTYRET. FOR Å DEAKTIVISERE UTSTYRET, må strømforsyningen kobles fra.



ELEKTRISK - TYPE I- KLASSE UTSTYR

DETTE UTSTYRET MÅ JORDES. Strømkontakten må være tilkopleet en korrekt jordet kontakt. En kontakt som ikke er korrekt jordet kan føre til farlig spenninger i lett t ilgjengelige metalleder.



UTSTYR FOR STIKKONTAKT. Stikkontakten skal monteres i nærheten av utstyret og skal være lett tilgjengelig."



FORSIKTIG: Lufterventilene må ikke blokkeres, og må ha fri tilgang til luft med romtemperatur for avkjøling.



DRIFTSTEMPERATUR: Dette produktet er konstruert for bruk i maksimum romtemperatur på 50 grader celsius.



ELEKTRISK OVERBELASTNING PÅ AC HOVEDKRETSLØP

Når produktet installeres, må de samlede navneplateverdiene kontrolleres nøye når strøm påsettes.



FORSIKTIG: MEKANISK LASTNING Installering av utstyret på hyllen må utføres på en slik måte at ingen farlige situasjoner oppstår som en følge av ujevn lastning.



Litiumbatteri — Må kun byttes ut av en faglig kvalifisert tekniker.

FORSIKTIG: Eksplosjonsfare hvis batteriet feilinnsettes. Batteriet må bare erstattes med samme type eller en tilsvarende type som er anbefalt av fabrikanten. Batteriene må kasseres i samsvar med fabrikantens instruksjoner.



ALLE LAND: Produktet må installeres i samsvar med de lokale og nasjonale elektriske koder.



Advarsel: VED TILKOPLING TIL ET LIKESTRØMSNETT, SKAL DU BARE MONTERE UTSTYRET PÅ ET STED HVOR UVEDKOMNE IKKE HAR ADGANG.



Advarsel: DETTE UTSTYRET SKAL BARE MONTERES ELLER SKIFTES UT AV KVALIFISERT PERSONELL SOM HAR GJENNOMGÅTT OPPLÆRING.



Advarsel: Av sikkerhetshensyn bør en automatsikring på 15 A monteres i forsyningsenden av kabelen som skal brukes sammen med dette LAN-utstyret.

Du skal ALLTID først kople ledningene til LAN-utstyret før du kople ledningene til automatsikringen. Arbeid aldri med ledninger uten at strømmen er slått av, ettersom det ellers kan være fare for personskader som følge av elektrisk støt. Pass alltid på at automatsikringer er slått AV før du kople ledningene til automatsikringen.



Advarsel: Du skal ikke avisolere mer av ledningen enn det som er anbefalt. Dersom du avisolere mer enn det som er anbefalt, kan dette forårsake en sikkerhetsfare, ettersom det vil finnes uisolert ledning på rekkeklemmen etter montering.



Advarsel: Når du monterer dette utstyret, skal du alltid passe på at forbindelsen til rammejordingen monteres først og koples fra sist.



Advarsel: "Sikkerhetsfare" Kontroller om uisolerte koppertråder stikker ut av den monterte ledningen. Hvis monteringen er riktig utført, skal det ikke finnes uisolerte kobbertråder som stikker ut fra rekkeklemmen. Uisolerte ledninger kan lede skadelige mengder strøm til personer som berører ledningene.



Merknad: Systemet fungerer med positivt og negativt jordede likestrømssystemer.

Segurança



AVISO: Num ambiente doméstico este produto pode causar interferência na radiorrecepção e, neste caso, pode ser necessário que o utente tome as medidas adequadas.



AVISO Produto laser de classe I



AVISO Não olhe fixamente para o raio.



AVISOS SOBRE CARACTERÍSTICAS ELÉTRICAS

ATENÇÃO: PERIGO DE CHOQUE ELÉTRICO

Para evitar CHOQUE ELÉTRICO, não retire a tampa. Não contém peças que possam ser consertadas pelo usuário. Este aparelho contém VOLTAGENS PERIGOSAS e só deve ser aberto por um técnico qualificado e treinado.



PERIGO DE CHOQUE CAUSADO POR RAIOS

PERIGO: NÃO TRABALHE no equipamento ou nos CABOS durante períodos suscetíveis a QUEDAS DE RAIOS.



CUIDADO: O CABO DE ALIMENTAÇÃO É UTILIZADO COMO UM DISPOSITIVO DE DESCONEXÃO. PARA DESELETRIFICAR O EQUIPAMENTO, desconecte o cabo de ALIMENTAÇÃO.



ELÉTRICO - EQUIPAMENTOS DO TIPO CLASSE I DEVE SER FEITA LIGAÇÃO DE FIO TERRA PARA ESTE EQUIPAMENTO. O plugue de alimentação deve ser conectado a uma tomada com adequada ligação de fio terra. Tomadas sem adequada ligação de fio terra podem transmitir voltagens perigosas a peças metálicas expostas.



EQUIPAMENTO DE LIGAÇÃO, a tomada eléctrica deve estar instalada perto do equipamento e ser de fácil acesso.”



CUIDADO: As aberturas de ventilação não devem ser bloqueadas e devem ter acesso livre ao ar ambiente para arrefecimento adequado do aparelho.



TEMPERATURA DE FUNCIONAMENTO: Este produto foi projetado para uma temperatura ambiente máxima de 50 graus centígrados.



ELÉTRICO - SOBRECARGA DA REDE DE CORRENTE ALTERNADA (AC)

Antes de instalar o produto, verifique o efeito cumulativo da conexão de diversos aparelhos à rede de corrente alternada através das etiquetas que indicam potência ou amperagem.



CUIDADO: CARREGAMENTO - O equipamento deverá ser montado no suporte de montagem de forma tal que não cause perigo devido a carregamento não uniforme.



Bateria de lítio - Só deve ser trocada por técnico qualificado e treinado.
CUIDADO: Se a bateria não for devidamente instalada há perigo de explosão. Substitua somente pelo mesmo tipo ou equivalente, conforme recomendado pelo fabricante. Descarte baterias usadas, de acordo com as instruções fornecidas pelo fabricante.



TODOS OS PAÍSES: Instale o produto de acordo com as normas nacionais e locais para instalações elétricas.



Aviso: PARA UMA LIGAÇÃO CC CENTRALIZADA, INSTALE APENAS NUMA ZONA DE ACESSO RESTRITO.



Aviso: SÓ PESSOAL TREINADO E QUALIFICADO PODE INSTALAR OU SUBSTITUIR ESTE EQUIPAMENTO.



Aviso: Como medida de precaução, deve instalar-se um disjuntor de 15 Amp na extremidade de alimentação do cabo a ser usado com este equipamento LAN.

Ligue **SEMPRE** os cabos ao equipamento LAN primeiro antes de os ligar ao disjuntor. Para evitar o perigo de ferimentos por choque eléctrico, não trabalhe com alimentadores LIGADOS. Verifique sempre se o disjuntor está na posição OFF (desligado) antes de ligar os cabos ao mesmo.



Aviso: Não corte mais fio do que recomendado. Cortar mais do que o recomendado pode ser perigoso, por deixar fio exposto no terminal depois da instalação.



Aviso: Ao ligar este equipamento, instale sempre primeiro a ligação à terra e desligue-a sempre em último.



Aviso: “Perigo” Verifique se há algum fio de cobre exposto a sair do fio instalado. Quando esta instalação é feita correctamente não deve haver qualquer fio de cobre exposto a sair do terminal. Qualquer fio exposto pode conduzir níveis perigosos de electricidade para a pessoa que toque nos fios.



Nota: Este sistema funciona com sistemas CC com ligações à terra Positivas ou Negativas.

Seguridad



ADVERTENCIA: en un entorno doméstico, este producto puede causar radiointerferencias, en cuyo caso, puede requerirse del usuario que tome las medidas que sean convenientes al respecto.



¡**ADVERTENCIA!** Producto láser Clase I.



¡**ADVERTENCIA!** No mirat fijamente el haz.



AVISOS ELECTRICOS

ADVERTENCIA: PELIGRO DE ELECTROCHOQUE

Para evitar un ELECTROCHOQUE, no quite la tapa. No hay ningún componente en el interior al cual puede prestar servicio el usuario. Esta unidad contiene VOLTAJES PELIGROSOS y sólo deberá abrirla un técnico entrenado y calificado.



PELIGRO DE RAYOS

PELIGRO: NO REALICE NINGUN TIPO DE TRABAJO O CONEXION en los equipos o en LOS CABLES durante TORMENTAS ELECTRICAS.



ATENCION: EL CABLE DE ALIMENTACION SE USA COMO UN DISPOSITIVO DE DESCONEXION. PARA DESACTIVAR EL EQUIPO, desconecte el cable de alimentación.



ELECTRICO - EQUIPO DEL TIPO CLASE I

ESTE EQUIPO TIENE QUE TENER CONEXION A TIERRA. El cable tiene que conectarse a un enchufe a tierra debidamente instalado. Un enchufe que no está correctamente instalado podría ocasionar tensiones peligrosas en las partes metálicas que están expuestas.



EQUIPO CONECTABLE, el tomacorriente se debe instalar cerca del equipo, en un lugar con acceso fácil”.



ATENCION: Las aberturas para ventilación no deberán bloquearse y deberán tener acceso libre al aire ambiental de la sala para su enfriamiento.



TEMPERATURA REQUERIDA PARA LA OPERACIÓN: Este producto está diseñado para una temperatura ambiental máxima de 50 grados C.



ELECTRICO - SOBRECARGA DEL CIRCUITO PRIMARIO DE CORRIENTE ALTERNA

Al instalarse el producto deberán considerarse las potencias nominales acumulativas, cuando se conecta el equipo al cable de alimentación de corriente alterna.



ATENCION: CARGA MECANICA - El montaje del equipo en el bastidor debe realizarse de manera tal que no cause una condición peligrosa debido a la distribución desigual del peso.



Batería de litio - Sólo deberá ser cambiada por un técnico entrenado y calificado.
ATENCIÓN: Peligro de explosión si la batería no se reemplaza en forma correcta. Reemplace sólo con el mismo tipo o equivalente que recomienda el fabricante. Deseche las baterías usadas según las instrucciones del fabricante.



PARA TODOS LOS PAÍSES: Monte el producto de acuerdo con los Códigos Eléctricos locales y nacionales.



Advertencia: PARA HACER CONEXIONES DE CC CENTRALIZADAS, INSTALE EL CONMUTADOR ÚNICAMENTE EN LUGARES CON ACCESO RESTRINGIDO.



Advertencia: ÚNICAMENTE EMPLEADOS CAPACITADOS Y COMPETENTES TIENEN LA AUTORIZACIÓN DE INSTALAR O REPONER DICHO EQUIPO.



Advertencia: Por razones de precaución, se debe instalar un cortacircuitos de 15 amperios en el extremo de alimentación del cable que se utilizará con este equipo LAN.

SIEMPRE conecte los cables al equipo LAN primero, antes de conectarlos al cortacircuitos. Para evitar el peligro de sufrir daños corporales a causa de sacudidas eléctricas, no trabaje con conductores **CON CORRIENTE**. Asegúrese siempre de que el cortacircuitos esté en la posición de **APAGADO (OFF)** antes de conectar los cables al cortacircuitos.



Advertencia: No pele el cable más de la cantidad recomendada, ya que si después de instalar el bloque terminal quedan cables pelados, habrá riesgos de seguridad.



Advertencia: Cuando instale dicho equipo, asegúrese siempre de que el bastidor se conecte a tierra primero y se desconecte por último.



Advertencia: “Riesgo de seguridad” Cerciórese de que no haya hilos de cobre pelados que salgan del alambre instalado. Cuando dicha instalación se realiza correctamente, los hilos de cobre pelados no deben salir del bloque terminal. Todo alambre pelado puede conducir niveles de electricidad nocivos a la persona que lo toca.



Nota: Este sistema funcionará con sistemas de CC con conexión positiva o negativa a tierra.

Säkerhet



WARNING: Denna produkt kan ge upphov till radiostörningar i hemmet, vilket kan tvinga användaren till att vidtaga erforderliga åtgärder.



WARNING! Laserprodukt av klass I.



WARNING! Laserstrålning när enheten är öppen.



TILLKÄNNAGIVANDEN BETRÄFFANDE ELEKTRICITETSRIK:
RISK FÖR ELEKTRISK STÖT För att undvika ELEKTRISK stöt, ta ej av locket. Det finns inga delar inuti som behöver underhållas. Denna apparat är under HÖGSPÄNNING och får endast öppnas av en utbildad kvalificerad tekniker.



FARA FÖR BLIXTNEDSLAG

FARA: ARBETA EJ på utrustningen eller kablarna vid ÅSKVÄDER.



WARNING: NÄTKABELN ANVÄNDS SOM STRÖMBRYTARE FÖR ATT KOPPLA FRÅN STRÖMMEN, dra ur nätkabeln.



ELEKTRISKT - TYP KLASS I UTRUSTNING
DENNA UTRUSTNING MÅSTE VARA JORDAD. Nätkabeln måste vara ansluten till ett ordentligt jordat uttag. Ett felaktigt uttag kan göra att närliggande metalldelar utsätts för högspänning. Apparaten skall anslutas till jordat uttag, när den ansluts till ett nätverk.



UTRUSTNING MED PLUGG. Uttaget skall installeras i utrustningens närhet och vara lättåtkomligt”.



WARNING: Luftventilerna får ej blockeras och måste ha fri tillgång till omgivande rumsluft för avsvaning.



DRIFTSTEMPERATUR: Denna produkt är konstruerad för rumstemperatur ej överstigande 50 grader Celsius.



ELEKTRISKT - ÖVERBELASTNING AV VÄXELSTRÖMSNÄTET: När produkten installeras bör den sammanlagda effekten på namnplåten beaktas när apparaten ansluts till växelströmsnätet.



WARNING: MEKANISK BELASTNING: Utrustningen ska installeras i chassit på så sätt att fara inte uppstår p g a ojämn belastning.



Litium batteri - Får endast bytas av utbildade och kvalificerade tekniker.
WARNING: Risk för explosion om felaktigt batteri används. Byt endast mot samma eller likvärdig typ batteri, rekommenderat av tillverkaren. Kassera använda batterier i enlighet med tillverkarens instruktioner.



ALLA LÄNDER: Installera produkten i enlighet med lokala och statliga bestämmelser för elektrisk utrustning.



Warning: ANSLUTNING TILL LIKSTRÖMSNÄT FÅR ENDAST SKE I LOKAL DÄR OBEHÖRIGA EJ ÄGER TILLTRÄDE.



Warning: INSTALLATION OCH UTBYTE AV DENNA UTRUSTNING FÅR ENDAST UTFÖRAS AV AUKTORISERAD ELINSTALLATÖR.



Warning: Av säkerhetsskäl skall en 15 A automatsäkring anslutas till försörjningsänden på kabeln som används till denna LAN-utrustning.

Ledningar skall **ALLTID** anslutas till LAN-utrustningen innan ledningarna ansluts till automatsäkringen. För att förebygga uppkomsten av personsador orsakade av elektrisk stöt skall man inte vidröra strömförande uttag. Kontrollera alltid att automatsäkringen är i läget OFF (AV) innan anslutning av ledningar till automatsäkringen sker.



Warning: Skala inte av mer isolering än vad som anges ovan. Skalas för mycket isolering av kan fara uppstå om oskyddad tråd vidrörs på anslutningsplinten efter anslutningen.



Warning: Vid anslutning av denna utrustning skall man alltid se till att jordtråden ansluts först och lossas sist.



Warning: OBS! FARA! Kontrollera om små koppartrådar sticker ut ifrån den anslutna tråden. Om anslutningen utförts riktigt sticker inga trådar ut från anslutningsplinten. Oisolerade trådar kan överföra skadlig elektricitet till person som vidrör trådarna.



Anmärkning: Detta system fungerar både med positivt och negativt jordade likströmskällor.

Telecommunications Interfaces

The following statements apply to Network Service Module (NSM) and Port Interface Card (PIC) expansion options for Wide Area Network (WAN) links.



Warning To reduce risk of fire use only No.26 awg or larger telecommunications line cord if the cord supplied is not used with the apparatus.

Important Safety Instructions

When using your telephone equipment, basic safety precautions should always be followed to reduce the risk of fire, electric shock and injury to persons, including the following:

1. Do not use this product near water, for example near a bathtub, washbowl, kitchen sink, or laundry tub in a wet basement or near a swimming pool.
2. Avoid using a telephone (other than a cordless type) during an electrical storm. There may be remote risk of electric shock from lightning.
3. Do not use the telephone to report a gas leak in the vicinity of the leak.

4. Use only the power cord and batteries indicated in this manual. Do not dispose of batteries in a fire. They may explode. Check with local codes for possible special disposal instructions.
5. Remove the telephone cord from the unit prior to making changes to the expansion port.

Save these instructions

Connection to ISDN network

Ports for the connection of other apparatus

The following interfaces normally operate at SELV (Safe Extra Low Voltage) levels:

- Asynchronous (console) ports
- Ethernet ports
- G703 ports
- Synchronous ports

Note SELV is a secondary circuit whose voltages do not exceed a safe value under normal operating conditions and under single fault conditions. Under normal operating conditions the voltages do not exceed 42.4 V peak AC or 60 V DC.

TNVI

The following interfaces are Telecommunications Network Voltage (TNVI) circuits, which operate normally within the limits of SELV:

- BRI ports for connection to ISDN Basic Rate telecommunications networks
- PRI ports for connection to ISDN Primary Rate telecommunications networks
- E1/T1 ports for connection to E1/T1 services

Note A TNVI circuit is a circuit which under normal operating conditions does not exceed the limits for SELV and on which overvoltages from telecommunication networks are possible.

US Federal Communications Commission (FCC)

This equipment complies with Part 68 of the Federal Communications Commission (FCC) rules for the United States.

A label is located on the underside of the base unit containing the FCC registration number. You must, upon request, provide the following information to your local telephone company:

For the AR021U PIC

Facility Interface Code	021S5
-------------------------	-------

Service Order Code	6.0Y
--------------------	------

The AR021U PIC has completed the ISDN Ordering Codes Translation Review and is registered for IOC S and EZ-ISDN I.

USOC Jack Type	RJ49C
----------------	-------

Should you experience trouble with this telephone equipment, please contact:

Allied Telesis, Inc.
19800 North Creek Parkway, Suite 200
Bothell WA, 98011
Phone: 1 800 424 6596
Fax: 1 425 481 3895

If trouble is experienced with this equipment (AR021U PIC), for repair or warranty information, please contact the above. If the equipment is causing harm to the telephone network, the telephone company may request that you disconnect the equipment until the problem is resolved.

This equipment cannot be used on public coin phone service provided by the telephone company. Connection to party line service is subject to state tariffs.

Your telephone company may discontinue your service if your equipment causes harm to the telephone network. They will notify you in advance of disconnection, if possible. During notification, you will be informed of your right to file a complaint to the FCC.

Occasionally, your telephone company may make changes in its facilities, equipment, operation, or procedures that could affect the operation of your equipment. If so, you will be given advance notice of the change to give you an opportunity to maintain uninterrupted service.

Canadian Department of Communications

The Industry Canada label identifies certified equipment. This certification means that the equipment meets telecommunications network protective, operational and safety requirements as prescribed in the appropriate Terminal Equipment Technical Requirements document(s). The Department does not guarantee the equipment will operate to the user's satisfaction.

Before installing this equipment, users should ensure that it is permissible to be connected to the facilities of the local telecommunications company. The equipment must also be installed using an acceptable method of connection. The customer should be aware that compliance with the above conditions may not prevent degradation of service in some situations.

Repairs to certified equipment should be coordinated by a representative designated by the supplier. Any repairs or alterations made by the user to this equipment, or equipment malfunctions, may give the telecommunications company cause to request the user to disconnect the equipment.

Users should ensure for their own protection that the electrical ground connections of the power utility, telephone lines and internal metallic water pipe system, if present, are connected together. This precaution may be particularly important in rural areas.



Warning Users should not attempt to make such connections themselves, but should contact the appropriate electric inspection authority, or electrician, as appropriate.

This digital apparatus does not exceed the limits for radio noise emissions from digital apparatus as set out in the Radio Interface Regulations of the Canadian Department of Communications.

Le présent appareil numérique n'émet pas de bruits radioélectriques dépassant les limites applicables aux appareils numériques prescrites dans le Règlement sur le brouillage radioélectrique édicté par le ministère des Communications du Canada.