

# Management Software

---

**AT-S63**



## Features Guide

For Stand-alone AT-9400 Switches  
and AT-9400Ts Stacks

AT-S63 Version 2.2.0 for AT-9400 Layer 2+ Switches

AT-S63 Version 4.0.0 for AT-9400 Basic Layer 3 Switches

Copyright © 2009 Allied Telesis, Inc.

All rights reserved. No part of this publication may be reproduced without prior written permission from Allied Telesis, Inc.

Microsoft and Internet Explorer are registered trademarks of Microsoft Corporation. Netscape Navigator is a registered trademark of Netscape Communications Corporation. All other product names, company names, logos or other designations mentioned herein are trademarks or registered trademarks of their respective owners.

Allied Telesis, Inc. reserves the right to make changes in specifications and other information contained in this document without prior written notice. The information provided herein is subject to change without notice. In no event shall Allied Telesis, Inc. be liable for any incidental, special, indirect, or consequential damages whatsoever, including but not limited to lost profits, arising out of or related to this manual or the information contained herein, even if Allied Telesis, Inc. has been advised of, known, or should have known, the possibility of such damages.

# Contents

---

<b>Preface</b> .....	19
How This Guide is Organized .....	20
Product Documentation .....	22
Where to Go First .....	23
Starting a Management Session .....	24
Document Conventions .....	25
Contacting Allied Telesis .....	26
Online Support .....	26
Email and Telephone Support.....	26
Returning Products .....	26
Sales or Corporate Information .....	26
Management Software Updates.....	26
<b>Section I: Basic Operations</b> .....	<b>27</b>
<b>Chapter 1: Overview</b> .....	<b>29</b>
Layer 2+ and Basic Layer 3 Switches .....	30
AT-S63 Management Software .....	36
Management Interfaces.....	37
Management Access Methods .....	43
Local Management Sessions.....	43
Remote Telnet Sessions .....	43
Remote Secure Shell (SSH) Sessions.....	44
Remote Web Browser Session .....	44
Remote SNMP Management .....	44
Manager Access Levels .....	45
Installation and Management Configurations .....	46
Stand-alone Switches .....	46
AT-9400Ts Stacks.....	46
Enhanced Stacking .....	46
IP Configuration.....	47
Configuration Files.....	48
Stand-alone Switches .....	48
AT-9400Ts Stacks.....	48
Selecting a Configuration File .....	48
Redundant Twisted Pair Ports .....	49
History of New Features .....	51
Version 4.0.0.....	51
Version 3.2.0.....	53
Version 3.0.0.....	53
Version 2.1.0.....	54
Version 2.0.0.....	55
Version 1.3.0.....	55
Version 1.2.0.....	56

<b>Chapter 2: AT-9400Ts Stacks</b> .....	59
Supported Platforms .....	60
Introduction .....	61
AT-S63 Management Software .....	62
Supported Models .....	62
AT-StackXG Stacking Module .....	63
Maximum Number of Switches in a Stack .....	64
Management Interfaces .....	64
Management Access Methods .....	64
Enhanced Stacking .....	65
Stack Topology .....	66
Discovery Process .....	68
Master and Member Switches .....	69
Module ID Numbers .....	70
Stack Configuration Files .....	71
MAC Address Tables .....	73
File Systems .....	73
Compact Flash Memory Card Slots .....	73
Stack IP Address .....	74
Upgrading the AT-S63 Management Software .....	75
<b>Chapter 3: Enhanced Stacking</b> .....	77
Supported Platforms .....	78
Overview .....	79
Master and Slave Switches .....	80
Common VLAN .....	81
Master Switch and the Local Interface .....	82
Slave Switches .....	83
Enhanced Stacking Compatibility .....	84
Enhanced Stacking Guidelines .....	85
General Steps .....	86
<b>Chapter 4: SNMPv1 and SNMPv2c</b> .....	87
Supported Platforms .....	88
Overview .....	89
Community String Attributes .....	90
Community String Name .....	90
Access Mode .....	90
Operating Status .....	90
Open or Closed Access Status .....	90
Trap Receivers .....	90
Default SNMP Community Strings .....	92
<b>Chapter 5: MAC Address Table</b> .....	93
Overview .....	94
<b>Chapter 6: Static Port Trunks</b> .....	97
Supported Platforms .....	98
Overview .....	99
Load Distribution Methods .....	100
Guidelines .....	102
<b>Chapter 7: LACP Port Trunks</b> .....	103
Supported Platforms .....	104
Overview .....	105
LACP System Priority .....	106
Adminkey Parameter .....	107
LACP Port Priority Value .....	107

Load Distribution Methods .....	108
Guidelines .....	109
<b>Chapter 8: Port Mirror</b> .....	111
Supported Platforms .....	112
Overview .....	113
Guidelines .....	113
<b>Section II: Advanced Operations</b> .....	<b>115</b>
<b>Chapter 9: File System</b> .....	117
Overview .....	118
File Naming Conventions .....	119
Using Wildcards to Specify Groups of Files .....	120
<b>Chapter 10: Event Logs and the Syslog Client</b> .....	121
Supported Platforms .....	122
Overview .....	123
Event Messages .....	123
Syslog Client .....	124
<b>Chapter 11: Classifiers</b> .....	125
Supported Platforms .....	126
Overview .....	127
Classifier Criteria .....	129
Guidelines .....	134
<b>Chapter 12: Access Control Lists</b> .....	135
Supported Platforms .....	136
Overview .....	137
Parts of an ACL .....	139
Guidelines .....	140
Examples .....	141
<b>Chapter 13: Class of Service</b> .....	147
Supported Platforms .....	148
Overview .....	149
Scheduling .....	152
Strict Priority Scheduling .....	152
Weighted Round Robin Priority Scheduling .....	152
<b>Chapter 14: Quality of Service</b> .....	155
Supported Platforms .....	156
Overview .....	157
Classifiers .....	159
Flow Groups .....	160
Traffic Classes .....	161
Policies .....	162
QoS Policy Guidelines .....	163
Packet Processing .....	164
Bandwidth Allocation .....	164
Packet Prioritization .....	164
Replacing Priorities .....	166
VLAN Tag User Priorities .....	166
DSCP Values .....	166
DiffServ Domains .....	167
Examples .....	169

Voice Applications .....	169
Video Applications .....	171
Critical Database .....	173
Policy Component Hierarchy .....	174
<b>Chapter 15: Denial of Service Defenses</b> .....	<b>177</b>
Supported Platforms .....	178
Overview .....	179
SYN Flood Attack .....	180
Smurf Attack .....	181
Land Attack .....	182
Teardrop Attack .....	184
Ping of Death Attack .....	185
IP Options Attack .....	186
Mirroring Traffic .....	187
Denial of Service Defense Guidelines .....	188
<b>Chapter 16: Power Over Ethernet</b> .....	<b>189</b>
Supported Platforms .....	190
Overview .....	191
Power Budgeting .....	192
Port Prioritization .....	193
PoE Device Classes .....	194
<b>Section III: Snooping Protocols</b> .....	<b>195</b>
<b>Chapter 17: Internet Group Management Protocol Snooping</b> .....	<b>197</b>
Supported Platforms .....	198
Overview .....	199
<b>Chapter 18: Multicast Listener Discovery Snooping</b> .....	<b>201</b>
Supported Platforms .....	202
Overview .....	203
<b>Chapter 19: Router Redundancy Protocol Snooping</b> .....	<b>205</b>
Supported Platforms .....	206
Overview .....	207
Guidelines .....	208
<b>Chapter 20: Ethernet Protection Switching Ring Snooping</b> .....	<b>209</b>
Supported Platforms .....	210
Overview .....	211
Restrictions .....	213
Guidelines .....	215
<b>Section IV: SNMPv3</b> .....	<b>217</b>
<b>Chapter 21: SNMPv3</b> .....	<b>219</b>
Supported Platforms .....	220
Overview .....	221
SNMPv3 Authentication Protocols .....	222
SNMPv3 Privacy Protocol .....	223
SNMPv3 MIB Views .....	224
SNMPv3 Storage Types .....	226
SNMPv3 Message Notification .....	227
SNMPv3 Tables .....	228

SNMPv3 User Table .....	230
SNMPv3 View Table .....	230
SNMPv3 Access Table .....	230
SNMPv3 SecurityToGroup Table.....	230
SNMPv3 Notify Table.....	231
SNMPv3 Target Address Table .....	231
SNMPv3 Target Parameters Table .....	231
SNMPv3 Community Table.....	231
SNMPv3 Configuration Example .....	232

## **Section V: Spanning Tree Protocols ..... 233**

<b>Chapter 22: Spanning Tree and Rapid Spanning Tree Protocols .....</b>	<b>235</b>
Supported Platforms .....	236
Overview.....	237
Bridge Priority and the Root Bridge .....	238
Path Costs and Port Costs.....	239
Port Priority .....	240
Forwarding Delay and Topology Changes .....	242
Hello Time and Bridge Protocol Data Units (BPDU) .....	242
Point-to-Point and Edge Ports.....	243
Mixed STP and RSTP Networks .....	245
Spanning Tree and VLANs .....	246
<b>Chapter 23: Multiple Spanning Tree Protocol .....</b>	<b>247</b>
Supported Platforms .....	248
Overview.....	249
Multiple Spanning Tree Instance (MSTI).....	250
MSTI Guidelines .....	254
VLAN and MSTI Associations .....	255
Ports in Multiple MSTIs.....	256
Multiple Spanning Tree Regions .....	257
Region Guidelines.....	259
Common and Internal Spanning Tree (CIST) .....	260
MSTP with STP and RSTP .....	260
Summary of Guidelines .....	261
Associating VLANs to MSTIs.....	263
Connecting VLANs Across Different Regions .....	265

## **Section VI: Virtual LANs ..... 267**

<b>Chapter 24: Port-based and Tagged VLANs .....</b>	<b>269</b>
Supported Platforms .....	270
Overview.....	271
Port-based VLAN Overview.....	273
VLAN Name .....	273
VLAN Identifier .....	273
Untagged Ports .....	274
Port VLAN Identifier .....	274
Guidelines to Creating a Port-based VLAN.....	275
Drawbacks of Port-based VLANs.....	275
Port-based Example 1.....	276
Port-based Example 2.....	277
Tagged VLAN Overview .....	279
Tagged and Untagged Ports.....	280

Port VLAN Identifier .....	280
Guidelines to Creating a Tagged VLAN .....	280
Tagged VLAN Example .....	281
<b>Chapter 25: GARP VLAN Registration Protocol .....</b>	<b>283</b>
Supported Platforms .....	284
Overview .....	285
Guidelines .....	288
GVRP and Network Security .....	289
GVRP-inactive Intermediate Switches .....	290
Generic Attribute Registration Protocol (GARP) Overview .....	291
<b>Chapter 26: Multiple VLAN Modes .....</b>	<b>295</b>
Supported Platforms .....	296
Overview .....	297
802.1Q- Compliant Multiple VLAN Mode .....	298
Non-802.1Q Compliant Multiple VLAN Mode .....	300
<b>Chapter 27: Protected Ports VLANs .....</b>	<b>301</b>
Supported Platforms .....	302
Overview .....	303
Guidelines .....	305
<b>Chapter 28: MAC Address-based VLANs .....</b>	<b>307</b>
Supported Platforms .....	308
Overview .....	309
Egress Ports .....	310
VLANs That Span Switches .....	313
VLAN Hierarchy .....	315
Steps to Creating a MAC Address-based VLAN .....	316
Guidelines .....	317
<b>Section VII: Routing .....</b>	<b>319</b>
<b>Chapter 29: Internet Protocol Version 4 Packet Routing .....</b>	<b>321</b>
Supported Platforms .....	322
Overview .....	324
Routing Interfaces .....	326
VLAN ID (VID) .....	327
Interface Numbers .....	327
IP Address and Subnet Mask .....	327
Interface Names .....	329
Static Routes .....	330
Routing Information Protocol (RIP) .....	332
Default Routes .....	334
Equal-cost Multi-path (ECMP) Routing .....	335
Routing Table .....	337
Route Selection Process .....	338
Address Resolution Protocol (ARP) Table .....	339
Internet Control Message Protocol (ICMP) .....	340
Routing Interfaces and Management Features .....	342
Accessing Network Servers .....	342
Enhanced Stacking .....	343
Remote Telnet, SSH, and Web Browser Management Sessions .....	343
Pinging a Remote Device .....	344
Accessing DHCP or BOOTP Servers .....	344



Local Interface .....	345
AT-9408LC/SP AT-9424T/GB, and AT-9424T/SP Switches .....	346
Local Interface.....	346
ARP Table.....	346
Default Gateway.....	347
Routing Command Example.....	348
Creating the VLANs .....	349
Creating the Routing Interfaces .....	349
Adding a Static Route and Default Route .....	350
Adding RIP .....	351
Selecting the Local Interface.....	351
Non-routing Command Example .....	352
Upgrading from AT-S63 Version 1.3.0 or Earlier .....	354
<b>Chapter 30: BOOTP Relay Agent .....</b>	<b>355</b>
Supported Platforms .....	356
Overview.....	357
Guidelines.....	359
<b>Chapter 31: Virtual Router Redundancy Protocol .....</b>	<b>361</b>
Supported Platforms .....	362
Overview.....	363
Master Switch .....	364
Backup Switches .....	365
Interface Monitoring.....	366
Port Monitoring .....	367
VRRP on the Switch .....	368
<b>Section VIII: Port Security .....</b>	<b>371</b>
<b>Chapter 32: MAC Address-based Port Security .....</b>	<b>373</b>
Supported Platforms .....	374
Overview.....	375
Automatic .....	375
Limited.....	375
Secured.....	376
Locked.....	376
Invalid Frames and Intrusion Actions .....	377
Guidelines.....	378
<b>Chapter 33: 802.1x Port-based Network Access Control .....</b>	<b>379</b>
Supported Platforms .....	380
Overview.....	381
Authentication Process.....	383
Port Roles.....	384
None Role .....	384
Authenticator Role.....	384
Supplicant Role .....	386
Authenticator Ports with Single and Multiple Supplicants.....	387
Single Operating Mode .....	387
Multiple Operating Mode .....	391
Supplicant and VLAN Associations .....	394
Single Operating Mode .....	395
Multiple Operating Mode .....	395
Supplicant VLAN Attributes on the RADIUS Server.....	395
Guest VLAN.....	396

RADIUS Accounting.....	397
General Steps .....	398
Guidelines .....	399
<b>Section IX: Management Security .....</b>	<b>403</b>
<b>Chapter 34: Web Server .....</b>	<b>405</b>
Supported Platforms .....	406
Overview .....	407
Supported Protocols .....	407
Configuring the Web Server for HTTP .....	408
Configuring the Web Server for HTTPS .....	409
General Steps for a Self-signed Certificate .....	409
General Steps for a Public or Private CA Certificate .....	409
<b>Chapter 35: Encryption Keys .....</b>	<b>411</b>
Supported Platforms .....	412
Overview .....	413
Encryption Key Length .....	414
Encryption Key Guidelines .....	415
Technical Overview .....	416
Data Encryption .....	416
Data Authentication .....	418
Key Exchange Algorithms .....	419
<b>Chapter 36: PKI Certificates and SSL .....</b>	<b>421</b>
Supported Platforms .....	422
Overview .....	423
Types of Certificates .....	423
Distinguished Names .....	425
SSL and Enhanced Stacking .....	427
Guidelines .....	428
Technical Overview .....	429
SSL Encryption .....	429
User Verification .....	430
Authentication .....	430
Public Key Infrastructure .....	431
Public Keys .....	431
Message Encryption .....	431
Digital Signatures .....	431
Certificates .....	432
Elements of a Public Key Infrastructure .....	433
Certificate Validation .....	434
Certificate Revocation Lists (CRLs) .....	434
PKI Implementation .....	435
<b>Chapter 37: Secure Shell (SSH) .....</b>	<b>437</b>
Supported Platforms .....	438
Overview .....	439
Support for SSH .....	440
SSH Server .....	441
SSH Clients .....	442
SSH and Enhanced Stacking .....	443
SSH Configuration Guidelines .....	445
General Steps to Configuring SSH .....	446

<b>Chapter 38: TACACS+ and RADIUS Protocols</b> .....	447
Supported Platforms .....	448
Overview .....	449
Guidelines .....	451
<b>Chapter 39: Management Access Control List</b> .....	455
Supported Platforms .....	456
Overview .....	457
Parts of a Management ACE .....	458
IP Address .....	458
Mask .....	458
Application .....	458
Guidelines .....	459
Examples .....	460
<b>Appendix A: AT-S63 Management Software Default Settings</b> .....	463
Address Resolution Protocol Cache .....	465
Boot Configuration File .....	466
BOOTP Relay Agent .....	467
Class of Service .....	468
Denial of Service Defenses .....	469
802.1x Port-Based Network Access Control .....	470
Enhanced Stacking .....	472
Ethernet Protection Switching Ring (EPSR) Snooping .....	473
Event Logs .....	474
GVRP .....	475
IGMP Snooping .....	476
Internet Protocol Version 4 Packet Routing .....	477
MAC Address-based Port Security .....	478
MAC Address Table .....	479
Management Access Control List .....	480
Manager and Operator Account .....	481
Multicast Listener Discovery Snooping .....	482
Public Key Infrastructure .....	483
Port Settings .....	484
RJ-45 Serial Terminal Port .....	485
Router Redundancy Protocol Snooping .....	486
Server-based Authentication (RADIUS and TACACS+) .....	487
Server-based Authentication .....	487
RADIUS Client .....	487
TACACS+ Client .....	487
Simple Network Management Protocol .....	488
Simple Network Time Protocol .....	489
Spanning Tree Protocols (STP, RSTP, and MSTP) .....	490
Spanning Tree Switch Settings .....	490
Spanning Tree Protocol .....	490
Rapid Spanning Tree Protocol .....	490
Multiple Spanning Tree Protocol .....	491
Secure Shell Server .....	492
Secure Sockets Layer .....	493
System Name, Administrator, and Comments Settings .....	494
Telnet Server .....	495
Virtual Router Redundancy Protocol .....	496
VLANs .....	497
Web Server .....	498

<b>Appendix B: SNMPv3 Configuration Examples</b> .....	499
SNMPv3 Configuration Examples.....	500
SNMPv3 Manager Configuration.....	500
SNMPv3 Operator Configuration.....	501
SNMPv3 Worksheet .....	502
<b>Appendix C: Features and Standards</b> .....	505
10/100/1000Base-T Twisted Pair Ports .....	506
Denial of Service Defenses.....	506
Ethernet Protection Switching Ring Snooping .....	506
Fiber Optic Ports (AT-9408LC/SP Switch).....	507
File System .....	507
DHCP and BOOTP Clients .....	507
Internet Protocol Multicasting.....	507
Internet Protocol Version 4 Routing .....	507
MAC Address Table.....	508
Management Access and Security .....	508
Management Access Methods.....	509
Management Interfaces .....	509
Management MIBs.....	509
Port Security .....	510
Port Trunking and Mirroring .....	510
Spanning Tree Protocols .....	510
System Monitoring .....	510
Traffic Control .....	511
Virtual LANs .....	511
Virtual Router Redundancy Protocol.....	512
<b>Appendix D: MIB Objects</b> .....	513
Access Control Lists .....	514
Class of Service .....	515
Date, Time, and SNTP Client.....	516
Denial of Service Defenses.....	517
Enhanced Stacking .....	518
GVRP .....	519
MAC Address Table.....	521
Management Access Control List .....	522
Miscellaneous .....	523
Port Mirroring .....	524
Quality of Service.....	525
Port Configuration and Status.....	527
Spanning Tree .....	528
Static Port Trunk .....	529
VLANs .....	530
<b>Index</b> .....	533

# Figures

---

Figure 1: AT-StackXG Stacking Module .....	63
Figure 2: Duplex-chain Topology .....	66
Figure 3: Duplex-ring Topology .....	67
Figure 4: Static Port Trunk Example .....	99
Figure 5: User Priority and VLAN Fields within an Ethernet Frame.....	130
Figure 6: ToS field in an IP Header .....	131
Figure 7: ACL Example 1 .....	141
Figure 8: ACL Example 2 .....	142
Figure 9: ACL Example 3 .....	143
Figure 10: ACL Example 4 .....	144
Figure 11: ACL Example 5 .....	144
Figure 12: ACL Example 6 .....	145
Figure 13: DiffServ Domain Example .....	167
Figure 14: QoS Voice Application Example.....	170
Figure 15: QoS Video Application Example.....	172
Figure 16: QoS Critical Database Example .....	173
Figure 17: Policy Component Hierarchy Example .....	175
Figure 18: Double Fault Condition in EPSR Snooping .....	214
Figure 19: MIB Tree.....	224
Figure 20: SNMPv3 User Configuration Process .....	228
Figure 21: SNMPv3 Message Notification Process .....	229
Figure 22: Point-to-Point Ports .....	243
Figure 23: Edge Port .....	244
Figure 24: Point-to-Point and Edge Port.....	244
Figure 25: VLAN Fragmentation.....	246
Figure 26: VLAN Fragmentation with STP or RSTP.....	251
Figure 27: MSTP Example of Two Spanning Tree Instances .....	252
Figure 28: Multiple VLANs in a MSTI.....	253
Figure 29: Multiple Spanning Tree Region .....	258
Figure 30: CIST and VLAN Guideline - Example 1.....	263
Figure 31: CIST and VLAN Guideline - Example 2.....	264
Figure 32: Spanning Regions - Example 1 .....	265
Figure 33: Port-based VLAN - Example 1 .....	276
Figure 34: Port-based VLAN - Example 2 .....	277
Figure 35: Example of a Tagged VLAN.....	281
Figure 36: GVRP Example .....	286
Figure 37: GARP Architecture .....	292
Figure 38: GID Architecture.....	293
Figure 39: Example of a MAC Address-based VLAN Spanning Switches .....	313
Figure 40: Example of the Supplicant Role .....	386
Figure 41: Authenticator Port in Single Operating Mode with a Single Client.....	388
Figure 42: Single Operating Mode with Multiple Clients Using the Piggy-back Feature - Example 1 .....	389
Figure 43: Single Operating Mode with Multiple Clients Using the Piggy-back Feature - Example 2 .....	390
Figure 44: Single Operating Mode with Multiple Clients Using the Piggy-back Feature - Example 3 .....	391
Figure 45: Authenticator Port in Multiple Operating Mode - Example 1.....	392
Figure 46: Authenticator Port in Multiple Operating Mode - Example 2.....	393
Figure 47: SSH Remote Management of a Slave Switch.....	443



# Tables

---

Table 1: Basic Operations .....	30
Table 2: Advanced Operations .....	31
Table 3: Snooping Protocols .....	32
Table 4: SNMPv3 .....	32
Table 5: Spanning Tree Protocols .....	33
Table 6: Virtual LANs .....	33
Table 7: Internet Protocol Routing .....	34
Table 8: Port Security .....	34
Table 9: Management Security .....	35
Table 10: Management Interfaces .....	37
Table 11: Management Interfaces for Basic Operations .....	38
Table 12: Management Interfaces for Advanced Operations .....	39
Table 13: Management Interfaces for Snooping Protocols .....	40
Table 14: Management Interfaces for SNMPv3 .....	40
Table 15: Management Interfaces for Spanning Tree Protocols .....	40
Table 16: Management Interfaces for Virtual LANs .....	41
Table 17: Management Interfaces for Internet Protocol Routing .....	41
Table 18: Management Interfaces for Port Security .....	41
Table 19: Management Interfaces for Management Security .....	42
Table 20: Twisted Pair Ports Matched with GBIC and SFP Slots .....	49
Table 21: New Features in AT-S63 Version 3.0.0 .....	53
Table 22: New Features in AT-S63 Version 2.1.0 .....	54
Table 23: New Features in AT-S63 Version 2.0.0 .....	55
Table 24: New Features in AT-S63 Version 1.3.0 .....	55
Table 25: New Features in AT-S63 Version 1.2.0 .....	56
Table 26: Support for AT-9400Ts Stacks .....	60
Table 27: Management Interfaces for AT-9400Ts Stacks .....	60
Table 28: Maximum Number of Switches in a Stack of both 24-port and 48-port Switches .....	64
Table 29: Support for Enhanced Stacking .....	78
Table 30: Management Interfaces for Enhanced Stacking .....	78
Table 31: Support for SNMPv1 and SNMPv2c Community Strings .....	88
Table 32: Management Interfaces for SNMPv1 and SNMPv2c Community Strings .....	88
Table 33: Support for Static Port Trunks .....	98
Table 34: Management Interfaces for Static Port Trunks .....	98
Table 35: Support for LACP Port Trunks .....	104
Table 36: Management Interfaces for LACP Port Trunks .....	104
Table 37: Support for the Port Mirror .....	112
Table 38: Management Interfaces for the Port Mirror .....	112
Table 39: File Extensions and File Types .....	119
Table 40: Support for the Event Logs and the Syslog Client .....	122
Table 41: Management Interfaces for the Event Logs and the Syslog Client .....	122
Table 42: Support for Classifiers .....	126
Table 43: Management Interfaces for Classifiers .....	126
Table 44: Support for the Access Control Lists .....	136
Table 45: Management Interfaces for the Access Control Lists .....	136
Table 46: Support for the Class of Service Feature .....	148
Table 47: Management Interfaces for the Class of Service Feature .....	148
Table 48: Default Mappings of IEEE 802.1p Priority Levels to Priority Queues .....	150
Table 49: Customized Mappings of IEEE 802.1p Priority Levels to Priority Queues .....	150

Table 50: Example of Weighted Round Robin Priority .....	153
Table 51: Example of a Weight of Zero for Priority Queue 7 .....	153
Table 52: Support for Quality of Service .....	156
Table 53: Management Interfaces for Quality of Service .....	156
Table 54: Support for the Denial of Service Defenses .....	178
Table 55: Management Interfaces for the Denial of Service Defenses .....	178
Table 56: Support for the Power Over Ethernet Feature .....	190
Table 57: Management Interfaces for the Power Over Ethernet Feature .....	190
Table 58: Support for Internet Group Management Protocol Snooping .....	198
Table 59: Management Interfaces for Internet Group Management Protocol Snooping .....	198
Table 60: Support for Multicast Listener Discovery Snooping .....	202
Table 61: Management Interfaces for Multicast Listener Discovery Snooping .....	202
Table 62: Support for Router Redundancy Protocol Snooping .....	206
Table 63: Management Interfaces for Router Redundancy Protocol Snooping .....	206
Table 64: Support for Ethernet Protection Switching Ring Snooping .....	210
Table 65: Management Interfaces for Ethernet Protection Switching Ring Snooping .....	210
Table 66: Support for SNMPv3 .....	220
Table 67: Management Interfaces for the SNMPv3 .....	220
Table 68: Support for the Spanning Tree and Rapid Spanning Tree Protocols .....	236
Table 69: Management Interfaces for the Spanning Tree and Rapid Spanning Tree Protocols .....	236
Table 70: Bridge Priority Value Increments .....	238
Table 71: STP Auto-Detect Port Costs .....	239
Table 72: STP Auto-Detect Port Trunk Costs .....	240
Table 73: RSTP Auto-Detect Port Costs .....	240
Table 74: RSTP Auto-Detect Port Trunk Costs .....	240
Table 75: Port Priority Value Increments .....	241
Table 76: Support for the Multiple Spanning Tree Protocol .....	248
Table 77: Management Interfaces for the Multiple Spanning Tree Protocol .....	248
Table 78: Support for the Port-based and Tagged VLANs .....	270
Table 79: Management Interfaces for the Port-based and Tagged VLANs .....	270
Table 80: Support for the GARP VLAN Registration Protocol .....	284
Table 81: Management Interfaces for the GARP VLAN Registration Protocol .....	284
Table 82: Support for the Multiple VLAN Modes .....	296
Table 83: Management Interfaces for the Multiple VLAN Modes .....	296
Table 84: 802.1Q-Compliant Multiple VLAN Example .....	298
Table 85: Support for the Protected Ports VLANs .....	302
Table 86: Management Interfaces for the Protected Ports VLANs .....	302
Table 87: Support for the MAC Address-based VLANs .....	308
Table 88: Management Interfaces for MAC Address-based VLANs .....	308
Table 89: Mappings of MAC Addresses to Egress Ports Example .....	310
Table 90: Revised Example of Mappings of MAC Addresses to Egress Ports .....	311
Table 91: Example of a MAC Address-based VLAN Spanning Switches .....	314
Table 92: Support for IPv4 Packet Routing .....	322
Table 93: Management Interfaces for IPv4 Packet Routing .....	322
Table 94: ICMP Messages Implemented on the AT-9400 Switch .....	340
Table 95: IPv4 Routing Example .....	348
Table 96: Support for the BOOTP Relay Agent .....	356
Table 97: Management Interfaces for the BOOTP Relay Agent .....	356
Table 98: Support for the Virtual Router Redundancy Protocol .....	362
Table 99: Management Interfaces for the Virtual Router Redundancy Protocol .....	362
Table 100: Support for MAC Address-based Port Security .....	374
Table 101: Management Interfaces for MAC Address-based Port Security .....	374
Table 102: Support for 802.1x Port-based Network Access Control .....	380
Table 103: Management Interfaces for 802.1x Port-based Network Access Control .....	380
Table 104: Support for the Web Server .....	406
Table 105: Management Interfaces for the Web Server .....	406
Table 106: Support for Encryption Keys .....	412
Table 107: Management Interfaces for Encryption Keys .....	412
Table 108: Support for PKI Certificates and SSL .....	422
Table 109: Management Interfaces for PKI Certificates and SSL .....	422



Table 110: Support for the Secure Shell Protocol .....	438
Table 111: Management Interfaces for the Secure Shell Protocol .....	438
Table 112: Support for the TACACS+ and RADIUS Protocols .....	448
Table 113: Management Interfaces for the TACACS+ and RADIUS Protocols .....	448
Table 114: Support for the Management Access Control List .....	456
Table 115: Management Interfaces for the Management Access Control List .....	456
Table 116: Access Control Lists (AtiStackSwitch MIB) .....	514
Table 117: CoS Scheduling (AtiStackSwitch MIB) .....	515
Table 118: CoS Priority to Egress Queue Mappings (AtiStackSwitch MIB) .....	515
Table 119: CoS Packet Weights of Egress Queues (AtiStackSwitch MIB) .....	515
Table 120: CoS Port Settings (AtiStackSwitch MIB) .....	515
Table 121: Date, Time, and SNTP Client (AtiStackSwitch MIB) .....	516
Table 122: LAN Address and Subnet Mask (AtiStackSwitch MIB) .....	517
Table 123: Denial of Service Defenses (AtiStackSwitch MIB) .....	517
Table 124: Switch Mode and Discovery (AtiStackInfo MIB) .....	518
Table 125: Switches of an Enhanced Stack (AtiStackInfo MIB) .....	518
Table 126: GVFP Switch Configuration (AtiStackSwitch MIB) .....	519
Table 127: GVRP Port Configuration (AtiStackSwitch MIB) .....	519
Table 128: GVRP Counters (AtiStackSwitch MIB) .....	519
Table 129: MAC Address Table (AtiStackSwitch MIB) .....	521
Table 130: Static MAC Address Table (AtiStackSwitch MIB) .....	521
Table 131: Management Access Control List Status (AtiStackSwitch MIB) .....	522
Table 132: Management Access Control List Entries (AtiStackSwitch MIB) .....	522
Table 133: System Reset (AtiStackSwitch MIB) .....	523
Table 134: Local Interface (AtiStackSwitch MIB) .....	523
Table 135: Saving the Configuration and Returning to Default Settings (AtiStackSwitch MIB) .....	523
Table 136: Port Mirroring (AtiStackSwitch MIB) .....	524
Table 137: Flow Groups (AtiStackSwitch MIB) .....	525
Table 138: Traffic Classes (AtiStackSwitch MIB) .....	525
Table 139: Policies (AtiStackSwitch MIB) .....	526
Table 140: Port Configuration and Status (AtiStackSwitch MIB) .....	527
Table 141: Spanning Tree (AtiStackSwitch MIB) .....	528
Table 142: Static Port Trunks (AtiStackSwitch MIB) .....	529
Table 143: VLAN Table (AtiStackSwitch MIB) .....	530
Table 144: VLAN Table (AtiStackSwitch MIB) .....	530
Table 145: VLAN Mode and Uplink Port (AtiStackSwitch MIB) .....	530
Table 146: PVID Table (AtiStackSwitch MIB) .....	531



# Preface

---

This guide describes the features of the AT-9400 Layer 2+ and Basic Layer 3 Gigabit Ethernet Switches and the AT-S63 Management Software.

This preface contains the following sections:

- “How This Guide is Organized” on page 20
- “Product Documentation” on page 22
- “Where to Go First” on page 23
- “Starting a Management Session” on page 24
- “Document Conventions” on page 25
- “Contacting Allied Telesis” on page 26



## **Caution**

The software described in this documentation contains certain cryptographic functionality and its export is restricted by U.S. law. As of this writing, it has been submitted for review as a “retail encryption item” in accordance with the Export Administration Regulations, 15 C.F.R. Part 730-772, promulgated by the U.S. Department of Commerce, and conditionally may be exported in accordance with the pertinent terms of License Exception ENC (described in 15 C.F.R. Part 740.17). In no case may it be exported to Cuba, Iran, Iraq, Libya, North Korea, Sudan, or Syria. If you wish to transfer this software outside the United States or Canada, please contact your local Allied Telesis sales representative for current information on this product’s export status.

---

## How This Guide is Organized

---

This guide has the following sections and chapters:

□ Section I: Basic Operations

Chapter 1, “Overview” on page 29

Chapter 2, “AT-9400Ts Stacks” on page 59

Chapter 3, “Enhanced Stacking” on page 77

Chapter 4, “SNMPv1 and SNMPv2c” on page 87

Chapter 5, “MAC Address Table” on page 93

Chapter 6, “Static Port Trunks” on page 97

Chapter 7, “LACP Port Trunks” on page 103

Chapter 8, “Port Mirror” on page 111

□ Section II: Advanced Operations

Chapter 9, “File System” on page 117

Chapter 10, “Event Logs and the Syslog Client” on page 121

Chapter 11, “Classifiers” on page 125

Chapter 12, “Access Control Lists” on page 135

Chapter 13, “Class of Service” on page 147

Chapter 14, “Quality of Service” on page 155

Chapter 15, “Denial of Service Defenses” on page 177

Chapter 16, “Power Over Ethernet” on page 189

□ Section III: Snooping Protocols

Chapter 17, “Internet Group Management Protocol Snooping” on page 197

Chapter 18, “Multicast Listener Discovery Snooping” on page 201

Chapter 19, “Router Redundancy Protocol Snooping” on page 205

Chapter 20, “Ethernet Protection Switching Ring Snooping” on page 209

□ Section IV: SNMPv3

Chapter 21, “SNMPv3” on page 219

- ❑ Section V: Spanning Tree Protocols
  - Chapter 22, “Spanning Tree and Rapid Spanning Tree Protocols” on page 235
  - Chapter 23, “Multiple Spanning Tree Protocol” on page 247
- ❑ Section VI: Virtual LANs
  - Chapter 24, “Port-based and Tagged VLANs” on page 269
  - Chapter 25, “GARP VLAN Registration Protocol” on page 283
  - Chapter 26, “Multiple VLAN Modes” on page 295
  - Chapter 27, “Protected Ports VLANs” on page 301
  - Chapter 28, “MAC Address-based VLANs” on page 307
- ❑ Section VII: Routing
  - Chapter 29, “Internet Protocol Version 4 Packet Routing” on page 321
  - Chapter 30, “BOOTP Relay Agent” on page 355
  - Chapter 31, “Virtual Router Redundancy Protocol” on page 361
- ❑ Section VIII: Port Security
  - Chapter 32, “MAC Address-based Port Security” on page 373
  - Chapter 33, “802.1x Port-based Network Access Control” on page 379
- ❑ Section IX: Management Security
  - Chapter 34, “Web Server” on page 405
  - Chapter 35, “Encryption Keys” on page 411
  - Chapter 36, “PKI Certificates and SSL” on page 421
  - Chapter 37, “Secure Shell (SSH)” on page 437
  - Chapter 38, “TACACS+ and RADIUS Protocols” on page 447
  - Chapter 39, “Management Access Control List” on page 455
- ❑ Appendices
  - Appendix A, “AT-S63 Management Software Default Settings” on page 463
  - Appendix B, “SNMPv3 Configuration Examples” on page 499
  - Appendix C, “Features and Standards” on page 505
  - Appendix D, “MIB Objects” on page 513

## Product Documentation

---

For overview information on the features of the AT-9400 Switch and the AT-S63 Management Software, refer to:

- ❑ AT-S63 Management Software Features Guide  
(PN 613-001022)

For instructions on how to start a local or remote management session on a stand-alone AT-9400 Switch or a stack, refer to:

- ❑ Starting an AT-S63 Management Session Guide  
(PN 613-001023)

For instructions on how to install or manage a stand-alone AT-9400 Switch, refer to:

- ❑ AT-9400 Gigabit Ethernet Switch Installation Guide  
(PN 613-000987)
- ❑ AT-S63 Management Software Menus User's Guide  
(PN 613-001025)
- ❑ AT-S63 Management Software Command Line User's Guide  
(PN 613-001024)
- ❑ AT-S63 Management Software Web Browser User's Guide  
(PN 613-001026)

For instructions on how to install or manage an AT-9400Ts Stack, refer to:

- ❑ AT-9400Ts Stack Installation Guide  
(PN 613-000796)
- ❑ AT-S63 Management Software Command Line User's Guide  
(PN 613-001024)
- ❑ AT-S63 Management Software Web Browser User's Guide for  
AT-9400Ts Stacks  
(PN 613-001028)

The installation and user guides for all the Allied Telesis products are available in portable document format (PDF) on our web site at **[www.alliedtelesis.com](http://www.alliedtelesis.com)**. You can view the documents online or download them onto a local workstation or server.

## Where to Go First

---

Allied Telesis recommends that you read Chapter 1, “Overview” on page 29 in this guide before you begin to manage the switch for the first time. There you will find a variety of basic information about the unit and the management software, like the two levels of manager access levels and the different types of management sessions. You should also read Chapter 2, “AT-9400Ts Stacks” on page 59 if you are managing a stack of the AT-9424Ts, AT-9424Ts/XP and AT-9448Ts/XP Switches.

This guide is your resource for background information on the features of the switch. You can refer here for the relevant concepts and guidelines when you configure a feature for the first time.

## Starting a Management Session

---

For instructions on how to start a local or remote management session on the AT-9400 Switch, refer to the *Starting an AT-S63 Management Session Guide*.



## Document Conventions

---

This document uses the following conventions:

---

**Note**

Notes provide additional information.

---

**Caution**

Cautions inform you that performing or omitting a specific action may result in equipment damage or loss of data.

---

**Warning**

Warnings inform you that performing or omitting a specific action may result in bodily injury.

---

## Contacting Allied Telesis

---

This section provides Allied Telesis contact information for technical support and for sales and corporate information.

### Online Support

You can request technical support online by accessing the Allied Telesis Knowledge Base: [www.alliedtelesis.com/support/kb.aspx](http://www.alliedtelesis.com/support/kb.aspx). You can use the Knowledge Base to submit questions to our technical support staff and review answers to previously asked questions.

### Email and Telephone Support

For Technical Support via email or telephone, refer to the Allied Telesis web site at [www.alliedtelesis.com](http://www.alliedtelesis.com). Select your country from the list on the web site and then select the appropriate tab.

### Returning Products

Products for return or repair must first be assigned a return materials authorization (RMA) number. A product sent to Allied Telesis without an RMA number will be returned to the sender at the sender's expense. For instructions on how to obtain an RMA number, go to the Support section on our web site at [www.alliedtelesis.com](http://www.alliedtelesis.com).

### Sales or Corporate Information

You can contact Allied Telesis for sales or corporate information through our web site at [www.alliedtelesis.com](http://www.alliedtelesis.com).

### Management Software Updates

New releases of the management software for our managed products are available from the following Internet sites:

- Allied Telesis web site: [www.alliedtelesis.com](http://www.alliedtelesis.com)
- Allied Telesis FTP server: <ftp://ftp.alliedtelesis.com>

If the FTP server prompts you to log on, enter "anonymous" as the user name and your email address as the password.

## Section I

# Basic Operations

---

The chapters in this section contain background information on basic switch features. The chapters include:

- ❑ Chapter 1, "Overview" on page 29
- ❑ Chapter 2, "AT-9400Ts Stacks" on page 59
- ❑ Chapter 3, "Enhanced Stacking" on page 77
- ❑ Chapter 4, "SNMPv1 and SNMPv2c" on page 87
- ❑ Chapter 5, "MAC Address Table" on page 93
- ❑ Chapter 6, "Static Port Trunks" on page 97
- ❑ Chapter 7, "LACP Port Trunks" on page 103
- ❑ Chapter 8, "Port Mirror" on page 111



## Chapter 1

# Overview

---

This chapter has the following sections:

- ❑ “Layer 2+ and Basic Layer 3 Switches” on page 30
- ❑ “AT-S63 Management Software” on page 36
- ❑ “Management Interfaces” on page 37
- ❑ “Management Access Methods” on page 43
- ❑ “Manager Access Levels” on page 45
- ❑ “Installation and Management Configurations” on page 46
- ❑ “IP Configuration” on page 47
- ❑ “Configuration Files” on page 48
- ❑ “Redundant Twisted Pair Ports” on page 49
- ❑ “History of New Features” on page 51

## Layer 2+ and Basic Layer 3 Switches

---

The switches in the AT-9400 Gigabit Ethernet Series are divided into two groups:

- Layer 2+ Switches
  - AT-9408LC/SP
  - AT-9424T/GB
  - AT-9424T/SP
- Basic Layer 3 Switches
  - AT-9424T
  - AT-9424T/POE
  - AT-9424Ts
  - AT-9424Ts/XP
  - AT-9448T/SP
  - AT-9448Ts/XP

Although the switches have many of the same features and capabilities, there are a number of significant differences. For instance, the Internet Protocol Version 4 packet routing feature is only supported on the Basic Layer 3 switches and is the reason for the group's name.

The following tables list the supported features on the various switches. The Stack column lists the features of the AT-9424Ts, AT-9424Ts/XP, and AT-9448Ts/XP Switches when they are installed as AT-9400Ts Stacks with the AT-StackXG Stacking Module.

(Y = supported features)

Table 1. Basic Operations

	Layer 2+ Switches			Basic Layer 3 Switches						
	08LC	24GB	24SP	24T	24T POE	24Ts	24XP	48SP	48XP	Stack
Local management	Y	Y	Y	Y	Y	Y	Y	Y	Y	Y
Remote Telnet management	Y	Y	Y	Y	Y	Y	Y	Y	Y	Y
Remote Secure Shell management	Y	Y	Y	Y	Y	Y	Y	Y	Y	Y
Remote web browser management	Y	Y	Y	Y	Y	Y	Y	Y	Y	Y

Table 1. Basic Operations

	Layer 2+ Switches			Basic Layer 3 Switches						
	08LC	24GB	24SP	24T	24T POE	24Ts	24XP	48SP	48XP	Stack
Multiple manager sessions				Y	Y	Y	Y	Y	Y	Y
TCP/IP pings	Y	Y	Y	Y	Y	Y	Y	Y	Y	Y
Enhanced stacking	Y	Y	Y	Y	Y	Y	Y	Y	Y	
Simple Network Time Protocol (SNTP)	Y	Y	Y	Y	Y	Y	Y	Y	Y	
SNMPv1 and SNMPv2	Y	Y	Y	Y	Y	Y	Y	Y	Y	Y
Port statistics	Y	Y	Y	Y	Y	Y	Y	Y	Y	Y
Static port trunks	Y	Y	Y	Y	Y	Y	Y	Y	Y	Y
Link Aggregation Control Protocol (LACP) trunks	Y	Y	Y	Y	Y	Y	Y	Y	Y	Y
Port mirroring	Y	Y	Y	Y	Y	Y	Y	Y	Y	Y

Table 2. Advanced Operations

	Layer 2+ Switches			Basic Layer 3 Switches						
	08LC	24GB	24SP	24T	24T POE	24Ts	24XP	48SP	48XP	Stack
File system	Y	Y	Y	Y	Y	Y	Y	Y	Y	Y <sup>1</sup>
Event logs	Y	Y	Y	Y	Y	Y	Y	Y	Y	Y <sup>2</sup>
TFTP client	Y	Y	Y	Y	Y	Y	Y	Y	Y	Y
Syslog client	Y	Y	Y	Y	Y	Y	Y	Y	Y	Y
Classifiers	Y	Y	Y	Y	Y	Y	Y	Y	Y	Y
Access control lists	Y	Y	Y	Y	Y	Y	Y	Y	Y	Y
Class of Service	Y	Y	Y	Y	Y	Y	Y	Y	Y	Y
Quality of Service	Y	Y	Y	Y	Y	Y	Y	Y	Y	Y

Table 2. Advanced Operations

	Layer 2+ Switches			Basic Layer 3 Switches						
	08LC	24GB	24SP	24T	24T POE	24Ts	24XP	48SP	48XP	Stack
Denial of service defenses	Y	Y	Y	Y	Y	Y	Y	Y	Y	
Power over Ethernet					Y					

1. The only accessible file system in a stack is on the master switch.
2. The only active event logs in a stack are on the master switch.

Table 3. Snooping Protocols

	Layer 2+ Switches			Basic Layer 3 Switches						
	08LC	24GB	24SP	24T	24T POE	24Ts	24XP	48SP	48XP	Stack
Internet Group Management Protocol (IGMP) snooping	Y	Y	Y	Y	Y	Y	Y	Y	Y	Y
Multicast Listener Discovery (MLD) snooping	Y	Y	Y	Y	Y	Y	Y	Y	Y	
Router Redundancy Protocol (RRP) snooping	Y	Y	Y	Y	Y	Y	Y	Y	Y	
Ethernet Protection Switching Ring (EPSR) snooping				Y	Y	Y	Y	Y	Y	

Table 4. SNMPv3

	Layer 2+ Switches			Basic Layer 3 Switches						
	08LC	24GB	24SP	24T	24T POE	24Ts	24XP	48SP	48XP	Stack
SNMPv3	Y	Y	Y	Y	Y	Y	Y	Y	Y	Y



Table 5. Spanning Tree Protocols

	Layer 2+ Switches			Basic Layer 3 Switches						
	08LC	24GB	24SP	24T	24T POE	24Ts	24XP	48SP	48XP	Stack
Spanning Tree Protocol (STP)	Y	Y	Y	Y	Y	Y	Y	Y	Y	Y
Rapid Spanning Tree Protocol (RSTP)	Y	Y	Y	Y	Y	Y	Y	Y	Y	Y
Multiple Spanning Tree Protocol (MSTP)	Y	Y	Y	Y	Y	Y	Y	Y	Y	

Table 6. Virtual LANs

	Layer 2+ Switches			Basic Layer 3 Switches						
	08LC	24GB	24SP	24T	24T POE	24Ts	24XP	48SP	48XP	Stack
Port-based and tagged VLANs	Y	Y	Y	Y	Y	Y	Y	Y	Y	Y
802.1Q-compliant and non-802.1Q-compliant multiple VLAN modes	Y	Y	Y	Y	Y	Y	Y	Y	Y	
GARP VLAN Registration Protocol	Y	Y	Y	Y	Y	Y	Y	Y	Y	
Protected ports VLANs	Y	Y	Y	Y	Y	Y	Y	Y	Y	
MAC address-based VLANs				Y	Y	Y	Y	Y	Y	

Table 7. Internet Protocol Routing

	Layer 2+ Switches			Basic Layer 3 Switches						
	08LC	24GB	24SP	24T	24T POE	24Ts	24XP	48SP	48XP	Stack
Static routes for Internet Protocol version 4 routing				Y	Y	Y	Y	Y	Y	Y
Routing Information Protocol (RIP)				Y	Y	Y	Y	Y	Y	
One routing interface <sup>1</sup>	Y	Y	Y	Y	Y	Y	Y	Y	Y	Y
Virtual Router Redundancy Protocol				Y	Y	Y	Y	Y	Y	
BOOTP and DHCP clients	Y	Y	Y	Y	Y	Y	Y	Y	Y	Y
BOOTP relay agent				Y	Y	Y	Y	Y	Y	Y

1. Used to assign the switch or stack an IP address configuration.

Table 8. Port Security

	Layer 2+ Switches			Basic Layer 3 Switches						
	08LC	24GB	24SP	24T	24T POE	24Ts	24XP	48SP	48XP	Stack
MAC address-based port security	Y	Y	Y	Y	Y	Y	Y	Y	Y	Y
802.1x port-based network access control using RADIUS protocol	Y	Y	Y	Y	Y	Y	Y	Y	Y	Y

Table 9. Management Security

	Layer 2+ Switches			Basic Layer 3 Switches						
	08LC	24GB	24SP	24T	24T POE	24Ts	24XP	48SP	48XP	Stack
Encryption keys	Y	Y	Y	Y	Y	Y	Y	Y	Y	Y
Public Key Infrastructure (PKI) certificates and Secure Sockets Layer (SSL) protocol	Y	Y	Y	Y	Y	Y	Y	Y	Y	Y
Remote Secure Shell management	Y	Y	Y	Y	Y	Y	Y	Y	Y	Y
Manager accounts using TACACS+ or RADIUS protocol	Y	Y	Y	Y	Y	Y	Y	Y	Y	Y <sup>1</sup>
Management access control list	Y	Y	Y	Y	Y	Y	Y	Y	Y	

- Stacks do not support the TACACS+ protocol. You can use the web browser interface to configure RADIUS accounting on a stack, but you cannot use the interface to enter the IP addresses of the RADIUS servers.

## AT-S63 Management Software

---

The AT-9400 Switch is managed with the AT-S63 Management Software. The software comes preinstalled on the unit with default settings for all the operating parameters of the switch. If the default settings are adequate for your network, you can use the switch as an unmanaged unit.

---

**Note**

The default settings are listed in Appendix A, “AT-S63 Management Software Default Settings” on page 463.

---

You can access the management software on the switch several different ways. You can manage the switch locally (out-of-band) using the Terminal Port on the front panel or over a network (in-band) using a Telnet or Secure Shell client, or a web browser. For further information, refer to “Management Access Methods” on page 43.

The management software has four management interfaces -- a menus interface, a standard command line interface, an AlliedWare Plus command line interface, and a web browser interface. You can use any of the interfaces to perform basic configuration procedures. But some of the newer and more complex features, such as Virtual Router Redundancy Protocol (VRRP), must be configured with the standard command line interface. For more information, refer to “Management Interfaces” on page 37.

There are two current versions of the management software. Version 2.2.0 is for the Layer 2+ switches and Version 4.0.0 is for the Basic Layer 3 switches.

---

**Note**

Do not install version 4.0.0 on a Layer 2+ switch.

---

## Management Interfaces

---

The AT-S63 Management Software has four management interfaces:

- Standard command line
- AlliedWare Plus command line
- Menus
- Web browser windows

As shown in Table 10, the standard command line and the web browser windows are supported on all of the possible platforms: stand-alone AT-9400 Layer 2+ Switches, stand-alone AT-9400 Basic Layer 3 Switches, and AT-9400 Stacks. The AlliedWare Plus command line is not supported on the AT-9400 Layer 2+ Switches and the menus interface is not supported on AT-9400 Stacks.

Table 10. Management Interfaces

	Standard Command Line	AlliedWare Plus Command Line	Menus	Web Browser Windows
AT-9400 Layer 2+ Switches	Y		Y	Y
AT-9400 Basic Layer 3 Switches	Y	Y	Y	Y
AT-9400 Stacks	Y	Y		Y

You can access the standard command line, the AlliedWare Plus command line and the menus from local management sessions and from remote Telnet and Secure Shell clients. The web browser windows are available from remote web browsers using either non-secure HTTP or secure HTTPS.

The standard command line is the only management interface that lets you configure all of the parameters on stand-alone switches and stacks. The other management interfaces support only a subset of the management functions. For instance, you can use any of the management interfaces to configure the basic settings of the ports (e.g., speeds and duplex modes), but you have to use the standard command line to configure VRRP.

In other cases, a management interface might support only part of a function. For example, you can set a switch or stack's name, contact or location with any of the management interfaces, except for the AlliedWare Plus commands, which only lets you set the name.

The following tables list the features you can configure from the various management interfaces for stand-alone switches and AT-9400Ts Stacks. The acronyms are as follows:

- SCL - Standard Command Line
- ACL - AlliedWare Plus Command Line
- M - Menus
- WB - Web browser

Table 11. Management Interfaces for Basic Operations

	Stand-alone Switches				Stacks		
	SCL	ACL	M	WB	SCL	ACL	WB
Switch's name, location, and contact	Y	Y <sup>1</sup>	Y	Y	Y	Y <sup>1</sup>	Y
Manager and operator passwords	Y		Y	Y	Y		Y
Date and time (manual and SNTP)	Y	Y	Y	Y	Y	Y	Y
Rebooting a switch	Y	Y	Y	Y	Y	Y	
Multiple manager sessions	Y	Y			Y	Y	
TCP/IP pings	Y	Y	Y	Y	Y	Y	Y
Enhanced stacking	Y		Y	Y			
SNMPv1 and SNMPv2 community strings	Y		Y	Y	Y		Y
Port parameters	Y	Y	Y	Y	Y	Y	Y
Port statistics	Y	Y	Y	Y	Y	Y	Y
MAC address table	Y	Y	Y	Y	Y	Y	Y
Static MAC addresses	Y	Y	Y	Y	Y	Y	Y
Static port trunks	Y	Y	Y	Y	Y	Y	Y
Link Aggregation Control Protocol (LACP) trunks	Y	Y	Y		Y	Y	
Port mirroring	Y	Y	Y	Y	Y	Y	Y
Baud rate of the Terminal Port	Y	Y	Y		Y	Y	

Table 11. Management Interfaces for Basic Operations

	Stand-alone Switches				Stacks		
	SCL	ACL	M	WB	SCL	ACL	WB
Management console timer	Y	Y	Y		Y	Y	
Telnet server	Y	Y	Y		Y	Y	
Console startup mode	Y		Y		Y		

1. You can use the AlliedWare Plus command line to set the name of the switch or stack, but not the contact or location.

Table 12. Management Interfaces for Advanced Operations

	Stand-alone Switches				Stacks		
	SCL	ACL	M	WB	SCL	ACL	WB
File system and configuration files	Y	Y	Y	Y <sup>1</sup>	Y	Y	Y <sup>2</sup>
Format flash memory	Y				Y		
File uploads and downloads	Y	Y <sup>3</sup>	Y	Y <sup>4</sup>	Y		Y <sup>5</sup>
Event logs	Y		Y	Y <sup>6</sup>	Y		Y <sup>6</sup>
Syslog client	Y		Y	Y	Y		Y
Classifiers	Y	Y	Y	Y	Y	Y	
Access control lists	Y	Y	Y	Y	Y	Y	
Class of Service	Y		Y	Y	Y		
Quality of Service	Y	Y	Y	Y	Y	Y	
Denial of service defenses	Y		Y	Y			
Power over Ethernet	Y		Y				

1. You can use the web browser windows to view the files in the file system of a switch or on a compact flash card, but you cannot: copy, rename, or delete them; change directories on a compact flash card; or create a new switch configuration file.
2. You can use the web browser windows to view the files in the file system of the master switch or on a compact flash card in the master switch, but you cannot: copy, rename, or delete files; change directories on a compact flash card; or create a new switch configuration file.
3. You can use the AlliedWare Plus command line to download new versions of the AT-S63 Management Software to stand-alone switches. You cannot use this interface to download new versions of the management software to stacks or to transfer files to the file system.
4. You cannot upload or download files to a compact flash card with the web browser windows. Also, that interface does not support switch-to-switch uploads.
5. You cannot upload or download files to a compact flash card with the web browser interface.

- 6. You cannot modify the event log full action from the web browser interface.

Table 13. Management Interfaces for Snooping Protocols

	Stand-alone Switches				Stacks		
	SCL	ACL	M	WB	SCL	ACL	WB
Internet Group Management Protocol (IGMP) snooping	Y	Y	Y	Y	Y	Y	Y
Multicast Listener Discovery (MLD) snooping	Y		Y				
Router Redundancy Protocol (RRP) snooping	Y		Y				
Ethernet Protection Switching Ring (EPSR) snooping	Y						

Table 14. Management Interfaces for SNMPv3

	Stand-alone Switches				Stacks		
	SCL	ACL	M	WB	SCL	ACL	WB
SNMPv3	Y		Y	Y	Y		Y

Table 15. Management Interfaces for Spanning Tree Protocols

	Stand-alone Switches				Stacks		
	SCL	ACL	M	WB	SCL	ACL	WB
Spanning Tree Protocol (STP)	Y	Y	Y	Y	Y	Y	Y
Rapid Spanning Tree Protocol (RSTP)	Y	Y	Y	Y	Y	Y	Y
Multiple Spanning Tree Protocol (MSTP)	Y	Y	Y	Y			



Table 16. Management Interfaces for Virtual LANs

	Stand-alone Switches				Stacks		
	SCL	ACL	M	WB	SCL	ACL	WB
Port-based and tagged VLANs	Y	Y	Y	Y	Y	Y	Y
802.1Q-compliant and non-802.1Q-compliant multiple VLAN modes	Y		Y	Y			
GARP VLAN Registration Protocol	Y		Y	Y			
Protected ports VLANs	Y		Y				
MAC address-based VLANs	Y		Y				

Table 17. Management Interfaces for Internet Protocol Routing

	Stand-alone Switches				Stacks		
	SCL	ACL	M	WB	SCL	ACL	WB
Routing interfaces	Y	Y	Y		Y	Y	
Static routes	Y	Y			Y	Y	
Routing Information Protocol (RIP)	Y						
Address Resolution Protocol (ARP) table	Y				Y		
BOOTP and DHCP clients	Y	Y	Y		Y	Y	
BOOTP relay agent	Y				Y		
Virtual Router Redundancy Protocol	Y						

Table 18. Management Interfaces for Port Security

	Stand-alone Switches				Stacks		
	SCL	ACL	M	WB	SCL	ACL	WB
MAC address-based port security	Y	Y	Y	Y	Y	Y	

Table 18. Management Interfaces for Port Security

	Stand-alone Switches				Stacks		
	SCL	ACL	M	WB	SCL	ACL	WB
802.1x port-based network access control	Y	Y	Y	Y	Y	Y	Y

Table 19. Management Interfaces for Management Security

	Stand-alone Switches				Stacks		
	SCL	ACL	M	WB	SCL	ACL	WB
Web server	Y	Y <sup>1</sup>	Y		Y	Y <sup>1</sup>	
Encryption keys	Y	Y	Y	Y <sup>2</sup>	Y	Y	
Public Key Infrastructure (PKI) certificates and Secure Sockets Layer (SSL) protocol	Y		Y	Y <sup>3</sup>	Y		
Secure Shell server	Y	Y	Y	Y	Y	Y	
TACACS+ and RADIUS authentication	Y	Y	Y	Y	Y	Y	
Management access control list	Y		Y	Y			

1. You can use the AlliedWare Plus command line to enable or disable the web server. To configure the server you have to use another management interface.
2. From the web browser interface you can view the encryption keys, but you cannot create or delete them.
3. You can use the web browser interface to view the PKI certificates and the SSL and PKI settings. You cannot create or delete certificates or certificate enrollment requests, or change the settings.

## Management Access Methods

---

You can access the AT-S63 Management Software on a switch several ways:

- Local session
- Remote Telnet session
- Remote Secure Shell (SSH) session
- Remote web browser (HTTP or HTTPS) session
- Remote SNMP session

### Local Management Sessions

To establish a local management session, you connect a terminal or a PC with a terminal emulator program to the Terminal Port on the front panel of the stand-alone switch or the master switch of a stack. This type of management session, which uses the management cable included with the unit, must be performed at the switch, hence the name “local.”

A switch or stack does not require an Internet Protocol (IP) configuration for local management.

Here are the management interfaces that are available to you from this type of management session:

- Standard command line
- AlliedWare Plus command line
- Menus

You can change between the interfaces during your management sessions.

---

#### Note

In most cases, the initial management session of a switch must be a local management session.

---

### Remote Telnet Sessions

The AT-S63 Management Software comes with a Telnet server for remote management of the unit from Telnet clients on your network. You can use these management interfaces from remote Telnet management sessions:

- Standard command line
- AlliedWare Plus command line
- Menus

## Remote Secure Shell (SSH) Sessions

The AT-S63 Management Software also has a Secure Shell (SSH) server for remote management from SSH clients on your network. An SSH management session is similar to a Telnet management session except it uses encryption to protect the session from snooping.

Here are the management interfaces that you can use from remote SSH management sessions:

- Standard command line
- AlliedWare Plus command line
- Menus

## Remote Web Browser Session

The AT-S63 Management Software also comes with a web browser server and a web browser interface for remote management using a web browser at a workstation on your network. A web browser session can be either non-encrypted (HTTP) or encrypted (HTTPS).

## Remote SNMP Management

You can also remotely configure the switch using a Simple Network Management Protocol (SNMP) application, such as AT-View. This management method requires an understanding of management information base (MIB) objects.

The AT-S63 Management Software supports the following MIBs:

- SNMP MIB-II (RFC 1213)
- Bridge MIB (RFC 1493)
- Interface Group MIB (RFC 2863)
- Ethernet MIB (RFC 1643)
- Remote Network MIB (RFC 1757)
- Allied Telesis managed switch MIBs

The Allied Telesis managed switch MIBs (atistackinfo.mib and atistackswitch.mib) are available from the Allied Telesis web site.

---

### Note

The switch must have an IP address for remote Telnet, SSH, or SNMP management. For background information, refer to “IP Configuration” on page 47.

---

## Manager Access Levels

---

The AT-S63 Management Software has two manager access levels of manager and operator. The manager access level lets you view and configure the operating parameters, while the operator access level only lets you only view the parameters settings.

You log in by entering the appropriate username and password when you start a management session. To log in as a manager, type “manager” as the login name. The default password is “friend.” The username for operator is “operator” and the default password is also “operator.” The usernames and passwords are case sensitive.

There can be up to three active manager sessions at a time on a switch. This is set with the SET SYSTEM command in the command line interface. The default is just one manager session.

There can be up to nine operator sessions if there are no active manager sessions. The maximum number of operator sessions is reduced by the same number of active manager sessions. For instance, if there are two active manager sessions, the maximum number of operator sessions is seven.

## Installation and Management Configurations

---

The AT-9400 Switches can be installed in three configurations.

### **Stand-alone Switches**

All the AT-9400 Switches can be installed as managed or unmanaged, stand-alone Gigabit Ethernet switches.

### **AT-9400Ts Stacks**

The AT-9424Ts, AT-9424Ts/XP and AT-9448Ts/XP Switches can be installed as a stack. This requires the AT-StackXG Stacking Module. The switches of a stack merge and synchronize their network operations to form a single, logical unit so that network functions, like the spanning tree protocols, virtual LANs, and static port trunks, can span all the Gigabit Ethernet ports of the units in the stack.

One of the advantages of stacking is that you can configure the switches from the same management session, rather than individually from different sessions. This can simplify management.

Another advantage is that it gives you more flexibility in customizing the features of the switches. For instance, the ports of a static port trunk on a stand-alone switch must be from the same switch, while the ports of a static trunk on a stack can be selected from different switches in the same stack.

For more information on stacking, refer to Chapter 2, “AT-9400Ts Stacks” on page 59.

### **Enhanced Stacking**

This feature is a management tool that can make it easier for you to configure the stand-alone AT-9400 Switches in your network. What this feature allows you to do is manage the switches from the same management session. With this feature you do not have to log out and log in again when you need to manage another device. Instead, when you are finished managing one switch in an enhanced stack, you can redirect the session to another unit without having to end the initial session.

It is important to note that even through the switches of an enhanced stack can be managed from the same management session, they are still stand-alone switches. They operate individually from each other and they have to be configured individually.

For more information, refer to Chapter 3, “Enhanced Stacking” on page 77.

## IP Configuration

---

Do you intend to remotely manage the switch with a Telnet or Secure Shell client, or a web browser? Or, will the management software be accessing application servers on your network, like a Simple Network Network Time Protocol server for setting its date and time, or a TFTP server for uploading or downloading files? If so, then the switch will need an IP configuration.

To assign an IP configuration to the switch, you need to create a routing interface. This takes planning because there are number of factors that have to be taken into account. For example, you need to know if the switch is an AT-9400 Layer 2+ Switch, which supports only one routing interface, or an AT-9400 Basic Layer 3 Switch, which supports more than one routing interface. If the answer is the latter, you also have to consider whether you plan to implement Internet Protocol version 4 packet routing on the switch. Furthermore, since routing interfaces are assigned to virtual LANs (VLANs), you might need to create one or more VLANs on the switch.

For background information, refer to “Routing Interfaces and Management Features” on page 342 in Chapter 29, “Internet Protocol Version 4 Packet Routing” on page 321. If your plans include implementing IPv4 packet routing, you should probably read the entire chapter. For background information on VLANs, refer to Chapter 24, “Port-based and Tagged VLANs” on page 269.

## Configuration Files

---

Stand-alone switches and stacks store their parameter settings in configuration files in their file systems. The devices use these files to configure their parameter settings whenever they initialize their management software, such as when you power on or reset the units.

The switches do not update the files automatically after you change a parameter setting. Instead, you must update the files by performing save commands in the management software. Once the parameter settings are saved in the configuration files, they are retained even when the switches or stacks are powered off.

You can upload the configuration files to a workstation or a TFTP server for editing or to maintain a history of the configurations of the switches or stacks.

### **Stand-alone Switches**

All of the switches in the AT-9400 Series come with a default boot configuration called BOOT.CFG for stand-alone operation. You can use this file or you can create another one. Each stand-alone switch must have its own configuration file, but you can transfer the files if you want different switches to have similar configurations.

### **AT-9400Ts Stacks**

When the AT-9424Ts, AT-9424Ts/XP, and AT-9448Ts/XP Switches are installed as a stack, they store their parameter settings in a single boot configuration file on the master switch. This one file contains the settings for all of the switches in a stack.

The default name of this file is STACK.CFG. The switches do not come with this file, but the master switch automatically creates it when you issue the SAVE CONFIGURATION command for the first time after you create a stack.

### **Selecting a Configuration File**

So how do the switches know which file to use? The AT-9400 Switches that can be used only as stand-alone units, such as the AT-9424T and AT-9424T/POE Switches, always use the BOOT.CFG file or its designated equivalent file.

The AT-9424Ts, AT-9424Ts/XP, and AT-9448Ts/XP Switches, which support both stand-alone and stack operations, select a configuration file based on their stack ID numbers. If the stack ID number is set to AUTO, meaning automatic, the switch assumes that it is a stand-alone switch and should use the BOOT.CFG file, or whatever stand-alone file you've designated. This is the default setting for the switches.

If the stack ID is set to STATIC, the switch assumes that it is part of a stack and that it should obtain its settings from the master switch. For more information, refer to "Stack Configuration Files" on page 71.



## Redundant Twisted Pair Ports

Several AT-9400 Switches have twisted pair ports and GBIC or SFP slots that are paired together. The twisted pair ports are identified with the letter “R” for “Redundant” as part of their number on the front faceplate of the unit. The switch models with paired ports and slots are listed in Table 20.

Table 20 Twisted Pair Ports Matched with GBIC and SFP Slots

Model	Ports and Slots
AT-9424T/GB	23R with GBIC slot 23 24R with GBIC slot 24
AT-9424T/SP	23R with SFP slot 23 24R with SFP slot 24
AT-9424T, AT-9424T/POE, AT-9424Ts and AT-9424Ts/XP	21R with SFP slot 21 22R with SFP slot 22 23R with SFP slot 23 24R with SFP slot 24
AT-9448T/SP	45R with SFP slot 45 46R with SFP slot 46 47R with SFP slot 47 48R with SFP slot 48

Follow these guidelines when using these ports and slots:

- Only one port in a pair — either the twisted pair port or the companion GBIC or SFP module — can be active at a time.
- The twisted pair port is the active port when its GBIC or SFP slot is empty, or when a GBIC or SFP module is installed but has not established a link to an end node.
- The twisted pair port automatically changes to the redundant status mode when a GBIC or SFP module establishes a link with an end node.
- A twisted pair port automatically transitions back to the active status when the link is lost on the GBIC or SFP module.
- A twisted pair port and a GBIC or SFP module share the same configuration settings, including port settings, VLAN assignments, access control lists, and spanning tree.
- The only exception to shared settings is port speed. If you disable Auto-Negotiation on a twisted pair port and set the speed and duplex mode manually, the speed reverts to Auto-Negotiation when a GBIC or SFP module establishes a link with an end node.

---

**Note**

These guidelines do not apply to the SFP slots on the AT-9408LC/SP Switch and the XFP slots on the AT-9424Ts/XP and AT-9448Ts/XP Switches.

---

## History of New Features

---

The following sections outline the history of the new features in the AT-S63 Management Software.

### Version 4.0.0 Stand-alone AT-9400 Switches

Here are the new and enhanced features in AT-S63 Management Software for stand-alone switches:

- ❑ Stand-alone switches now support up to three manager sessions at one time. To adjust this feature, which has a default setting of one manager session, use the SET SYSTEM command.
- ❑ The 802.1x port-based network access control feature is now fully compliant with the following:
  - Microsoft Network Access Protocol on Windows Server 2008, Windows Vista, and Windows XP Service Pack 3
  - Symantec Network Access Control
- ❑ The management software has a new command line interface based on the commands in the AlliedWare Plus operating system found on other Allied Telesis products, such as the Layer 3 switches. If you are already familiar with the commands in the AlliedWare Plus operating system, you may find this new interface more convenient to use than the standard command line. Some of the management functions you can perform with this new interface are:
  - Configure port parameters, such as Auto-Negotiation, speed, and duplex mode
  - Create new tagged and untagged VLANs
  - Create access control lists and Quality of Service policies
  - Create routing interfaces
  - View the MAC address table and add static addresses

---

#### Note

This version of the AT-S63 Management Software supports only a limited number of AlliedWare Plus commands. For further information, refer to the latest version of the *AT-S63 Management Software Command Line User's Guide*.

---

## AT-9400 Stacks

Here are the new and enhanced features in AT-S63 Management Software for AT-9400 Stacks:

- ❑ BOOTP/DHCP Relay Agent
- ❑ Access Control Lists
- ❑ Quality of Service policies
- ❑ IPv4 static routes
- ❑ Encrypted remote web browser management sessions with the Secure Sockets Layer protocol and the Public Key Infrastructure protocol
- ❑ Encrypted remote Secure Shell protocol management sessions
- ❑ AlliedWare Plus Command Line Interface.
- ❑ Stacks now support up to three manager sessions at one time. To adjust this feature, which has a default setting of one manager session, use the SET SYSTEM command.
- ❑ The LOAD command in the standard command line interface has a new parameter that will make it easier to update the switches in an AT-9400Ts Stack with future releases of the AT-S63 Management Software. In previous versions, you had to disassemble a stack and update the switches individually. But with the new MODULE parameter, you'll be able to update the management software on all the switches in a stack simultaneously.

---

### Note

The new MODULE parameter can only be used on stacks that already have Version 4.0.0 or later. To update member switches that have versions earlier than 4.0.0, you have to disconnect them from the stack and update them as stand-alone units.

---

- ❑ The 802.1x port-based network access control feature is now fully compliant with the following:
  - Microsoft Network Access Protocol on Windows Server 2008, Windows Vista, and Windows XP Service Pack 3
  - Symantec Network Access Control
- ❑ The commands used to control the MAC address table have a new MODULE parameter that lets you manage the MAC address tables on the individual switches of a stack.
- ❑ Switches assigned static ID numbers continue to use stack configuration files even when the stack stops operating and the switches revert to stand-alone units. This feature enables the switches to retain their stack configuration settings as stand-alone units, which

may lessen the impact to network operations if the stack encounters a problem.

**Version 3.2.0** This release added support for these features in AT-9400Ts Stacks:

- Remote web browser management
- Link Aggregation Control Protocol (LACP) trunks
- Internet Group Management Protocol (IGMP) snooping
- Internet Protocol Version 4 packet routing with static routes (Stacks do not support the Routing Information Protocol (RIP) or multipath routing.)
- Basic 802.1x port-based network access control (Stacks do not support MAC address-based authentication, Guest VLANs, or supplicant and VLAN associations.)

For a complete list of the features supported in a stack, refer to the Software Release Notes for the AT-S63 Version 3.2.0 Management Software or to the AT-S63 Stack Command Line User's Guide.

Version 3.2.0 did not include any new features for stand-alone AT-9400 Switches.

**Version 3.0.0** Table 21 lists the new features in version 3.0.0 of the AT-S63 Management Software.

Table 21. New Features in AT-S63 Version 3.0.0

Feature	Change
Stacking with the AT-StackXG Stacking Module	New feature. For information, refer to Chapter 1, Overview in the <i>AT-S63 Stack Command Line Interface User's Guide</i> .
Virtual Router Redundancy Protocol (VRRP)	New feature. For information, refer to Chapter 31, "Virtual Router Redundancy Protocol" on page 361.
Ethernet Protection Switching Ring (EPSR) snooping	New feature. For information, refer to Chapter 20, "Ethernet Protection Switching Ring Snooping" on page 209.
Internet Protocol version 4 packet routing	Added the following new features: <ul style="list-style-type: none"> <li><input type="checkbox"/> Split horizon with poison reverse</li> <li><input type="checkbox"/> Auto-summarization of routes</li> <li><input type="checkbox"/> DHCP/BOOTP relay</li> </ul>

Table 21. New Features in AT-S63 Version 3.0.0 (Continued)

Feature	Change
802.1x port-based network access control	Added the following authentication methods: <ul style="list-style-type: none"> <li data-bbox="971 415 1349 512">❑ EAP-TLS (Extensible Authentication Protocol - Transport Layer Security)</li> <li data-bbox="971 533 1349 659">❑ EAP-TTLS (Extensible Authentication Protocol - Tunneled Transport Layer Security)</li> <li data-bbox="971 680 1382 743">❑ PEAP (Protected Extensible Authentication Protocol)</li> </ul>

**Version 2.1.0** Table 22 lists the new features in version 2.1.0.

Table 22. New Features in AT-S63 Version 2.1.0

Feature	Change
Internet Protocol version 4 packet routing	Added the following new features: <ul style="list-style-type: none"> <li data-bbox="971 1045 1409 1171">❑ Equal Cost Multi-path (ECMP) for supporting multiple routes in the routing table to the same remote destination.</li> <li data-bbox="971 1192 1409 1318">❑ Variable length subnet masks for the IP addresses of routing interfaces and static and dynamic routes.</li> </ul>

**Version 2.0.0** Table 23 lists the new feature in version 2.0.0 of the AT-S63 Management Software.

Table 23. New Features in AT-S63 Version 2.0.0

Feature	Change
Internet Protocol version 4 packet routing with: <ul style="list-style-type: none"> <li data-bbox="537 499 824 531">❑ Routing interfaces</li> <li data-bbox="537 548 748 579">❑ Static routes</li> <li data-bbox="537 596 943 661">❑ Router Information Protocol (RIP) versions 1 and 2</li> </ul>	New feature.

**Version 1.3.0** Table 24 lists the new features in version 1.3.0 of the AT-S63 Management Software.

Table 24. New Features in AT-S63 Version 1.3.0

Feature	Change
802.1x Port-based Network Access Control	Added the following new features: <ul style="list-style-type: none"> <li data-bbox="1016 989 1458 1087">❑ Guest VLAN. For background information, see “Guest VLAN” on page 396.</li> <li data-bbox="1016 1104 1458 1373">❑ VLAN Assignment and Secure VLAN for supporting dynamic VLAN assignments from a RADIUS authentication server for supplicant accounts. For background information, see “Supplicant and VLAN Associations” on page 394.</li> <li data-bbox="1016 1390 1458 1629">❑ MAC address-based authentication as an alternative to 802.1x username and password authentication. For background information, refer to “Authentication Modes” on page 384.</li> </ul>
Management Access Control List	Simplified the menu interface for managing the access control entries in the Management ACL.

**Version 1.2.0** Table 25 lists the new features in version 1.2.0.

Table 25. New Features in AT-S63 Version 1.2.0

Feature	Change
MAC Address Table	<p>Added the following new parameters to the CLI commands for displaying and deleting specific types of MAC addresses in the MAC address table:</p> <ul style="list-style-type: none"> <li data-bbox="971 569 1398 737">❑ STATIC, STATICUNICAST, and, STATICMULTICAST for displaying and deleting static unicast and multicast MAC addresses.</li> <li data-bbox="971 758 1398 947">❑ DYNAMIC, DYNAMICUNICAST, and, DYNAMICMULTICAST for displaying and deleting dynamic unicast and multicast MAC addresses.</li> </ul>
Quality of Service	<p>Added the following new parameters to QoS flow groups, traffic classes, and policies:</p> <ul style="list-style-type: none"> <li data-bbox="971 1104 1365 1199">❑ ToS parameter for replacing the Type of Service field of IPv4 packets.</li> <li data-bbox="971 1220 1398 1377">❑ Move ToS to Priority parameter for replacing the value in the 802.1p priority field with the value in the ToS priority field in IPv4 packets.</li> <li data-bbox="971 1398 1398 1556">❑ Move Priority to ToS parameter for replacing the value in the ToS priority field with the 802.1p priority field in IPv4 packets.</li> <li data-bbox="971 1577 1398 1713">❑ Send to Mirror Port parameter for copying traffic to a destination mirror port (policies only)</li> </ul>
MLD Snooping	New feature.
MAC Address-based VLANs	New feature.



Table 25. New Features in AT-S63 Version 1.2.0 (Continued)

<b>Feature</b>	<b>Change</b>
802.1x Port-based Network Access Control	Added a new parameter to authenticator ports: <ul style="list-style-type: none"><li data-bbox="1015 401 1458 632">❑ Supplicant Mode for supporting multiple supplicant accounts on an authenticator port. For background information, see “Authenticator Ports with Single and Multiple Supplicants” on page 387.</li></ul>



## Chapter 2

# AT-9400Ts Stacks

---

This chapter has the following sections:

- ❑ “Supported Platforms” on page 60
- ❑ “Introduction” on page 61
- ❑ “AT-S63 Management Software” on page 62
- ❑ “Supported Models” on page 62
- ❑ “AT-StackXG Stacking Module” on page 63
- ❑ “Maximum Number of Switches in a Stack” on page 64
- ❑ “Management Interfaces” on page 64
- ❑ “Management Access Methods” on page 64
- ❑ “Enhanced Stacking” on page 65
- ❑ “Stack Topology” on page 66
- ❑ “Discovery Process” on page 68
- ❑ “Master and Member Switches” on page 69
- ❑ “Module ID Numbers” on page 70
- ❑ “Stack Configuration Files” on page 71
- ❑ “MAC Address Tables” on page 73
- ❑ “File Systems” on page 73
- ❑ “Compact Flash Memory Card Slots” on page 73
- ❑ “Stack IP Address” on page 74
- ❑ “Upgrading the AT-S63 Management Software” on page 75

## Supported Platforms

---

Table 26 and Table 27 list the AT-9400 Switches and the management interfaces that support AT-9400Ts Stacks.

Table 26. Support for AT-9400Ts Stacks

Switch	Supported
Layer 2+ Models	
AT-9408LC/SP	
AT-9424T/GB	
AT-9424T/SP	
Basic Layer 3 Models	
AT-9424T	
AT-9424T/POE	
AT-9424Ts	Yes
AT-9424Ts/XP	Yes
AT-9448T/SP	
AT-9448Ts/XP	Yes
AT-9400Ts Stacks	Yes

Table 27. Management Interfaces for AT-9400Ts Stacks

Stack	Standard Command Line	AlliedWare Plus Command Line	Menus	Web Browser
AT-9400Ts Stacks	Yes	Yes		Yes

## Introduction

---

The switches in the AT-9400 Series are divided into the Layer 2+ group and the Basic Layer 3 group. The two groups share many of the same features, but there are a number of significant differences. For instance, the Internet Protocol version 4 packet routing feature and the Virtual Router Redundancy Protocol are supported only on the Basic Layer 3 switches.

Three models in the Basic Layer 3 series support an additional feature called stacking. What stacking allows you to do is assemble the switches so that they function as a unified Gigabit Ethernet switch, rather than as independent units. As a stack, the switches synchronize their actions so that network operations, like spanning tree protocols, virtual LANs, and static port trunks, are able to span across all of their Gigabit Ethernet ports.

The two principal advantages of AT-9400Ts Stacks are:

- ❑ You can configure all of the switches in a stack simultaneously from the same management session, rather than individually from different sessions. This can simplify network management.
- ❑ You have more latitude in how you configure some of the features. For instance, when creating a static port trunk on a stand-alone switch you have to choose ports from the same switch. In contrast, a static trunk on a stack can have ports from different switches in the same stack.

## AT-S63 Management Software

---

Stacking requires Version 3.0.0 or later of the AT-S63 Management Software.

---

### Note

Version 3.0.0 is only supported on the AT-9424T, AT-9424T/POE, AT-9424Ts, AT-9424Ts/XP, AT-9448T/SP, and AT-9448Ts/XP Basic Layer 3 Switches. Do not install it on the AT-9408LC/SP, AT-9424T/GB, and AT-9424T/SP Layer 2+ Switches.

---

## Supported Models

---

Stacking is only supported on the following AT-9400 Switches:

- AT-9424Ts
- AT-9424Ts/XP
- AT-9448Ts/XP

## AT-StackXG Stacking Module

---

To be part of a stack, the AT-9400Ts Switch must have the AT-StackXG Stacking Module, shown in Figure 1. You install the module in the switch's expansion slot on the back panel. The installation instructions are provided in the *AT-9400Ts Stack Installation Guide*.

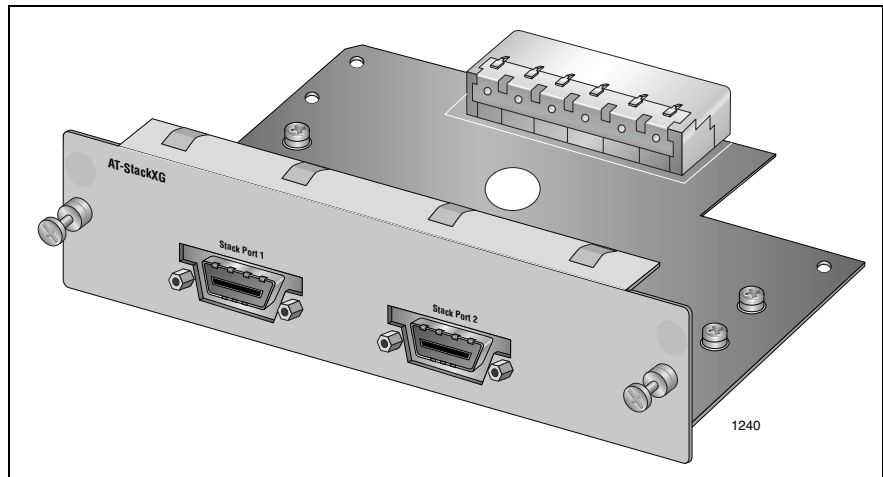

Figure 1. AT-StackXG Stacking Module

## Maximum Number of Switches in a Stack

---

Stacks of the 24-port AT-9424Ts Switch or the AT-9424Ts/XP Switch can have up to eight units. A stack can have both models and either model can be the master switch of the stack.

Allied Telesis does not recommend using the 48-port AT-9448Ts/XP Switch as the master switch of a stack. Consequently, a stack with one or more 48-port switches should have as the master switch the 24-port AT-9424Ts Switch or the AT-9424Ts/XP Switch. For stacks of more than three switches, both the master switch and the backup switch should be 24-port switches. A mixed stack of both 24-port and 48-port switches should not have more than four AT-9448Ts/XP Switches and should not exceed a total of eight units, as shown in this table.

Table 28. Maximum Number of Switches in a Stack of both 24-port and 48-port Switches

	Number of 24-Port AT-9424Ts and AT-9424Ts/XP Switches							
		1	2	3	4	5	6	7
Number of 48-Port AT-9448Ts/XP Switches	1							
	2							
	3							
	4							

## Management Interfaces

---

The AT-S63 Management Software has three management interfaces: menus, command line commands, and web browser windows. You can use either the command line commands or the web browser windows to manage a stack. The menus are only supported when the switches are used as stand-alone devices.

## Management Access Methods

---

You can manage a stack locally through the Terminal Port on the master switch or remotely using a Telnet client or a web browser (HTTP). A stack does not support the Secure Shell (SSH) protocol, secured web browser windows (HTTPS) or enhanced stacking.



## Enhanced Stacking

---

If you have prior experience with Allied Telesis products, you might already be familiar with a feature that happens to have a similar name to the feature discussed in this manual. The feature is *enhanced stacking* and what it allows you to do is manage the different Allied Telesis switches in your network from one management session by redirecting the management session from switch to switch. This can save you time as well as reduce the number of IP addresses that you have to assign to the managed devices in your network.

It is important not to confuse the stacking feature explained in this guide with enhanced stacking because they have no functional or operational similarities. Their principal differences are outlined here.

In an AT-9400Ts Stack:

- The AT-9400Ts Gigabit Ethernet Switches operate as a single, logical unit in which functions such as static port trunks and port mirrors, are able to span all the devices in the stack.
- The switches are managed as a unit.
- The switches in a stack have the same MAC address tables.
- The switches must be installed in the same equipment rack.
- The switches are linked together with the AT-StackXG Stacking Module.
- The stacking feature is only supported on the AT-9424Ts, AT-9424Ts/XP, and AT-9448Ts/XP Switches.

In enhanced stacking:

- The AT-9400 Gigabit Ethernet Switches operate as independent units.
- Though the switches of an enhanced stack can be accessed from the same management session, they must still be configured individually.
- Each switch maintains its own MAC address table.
- The devices can be located across a large geographical area.
- The switches are connected together with a common virtual LAN.
- Enhanced stacking is supported by all of the AT-9400 Gigabit Ethernet Switches, as well as other Allied Telesis managed products.

The AT-9400Ts Stack does not support enhanced stacking. A stack can be managed locally through the Terminal Port on the master switch of the stack or remotely with a Telnet or SSH client or a web browser.

## Stack Topology

The switches of an AT-9400Ts Stack are cabled with the AT-StackXG Stacking Module and its two full-duplex, 12-Gbps stacking ports. There are two supported topologies. The first topology is the duplex-chain topology, where a port on one stacking module is connected to a port on the stacking module in the next switch, which is connected to the next switch, and so on. The connections must crossover to different numbered ports on the modules. Port 1 on the stacking module in one switch must be connected to Port 2 on the stacking module in the next switch. An example of this topology of a stack of four switches is illustrated in Figure 2.

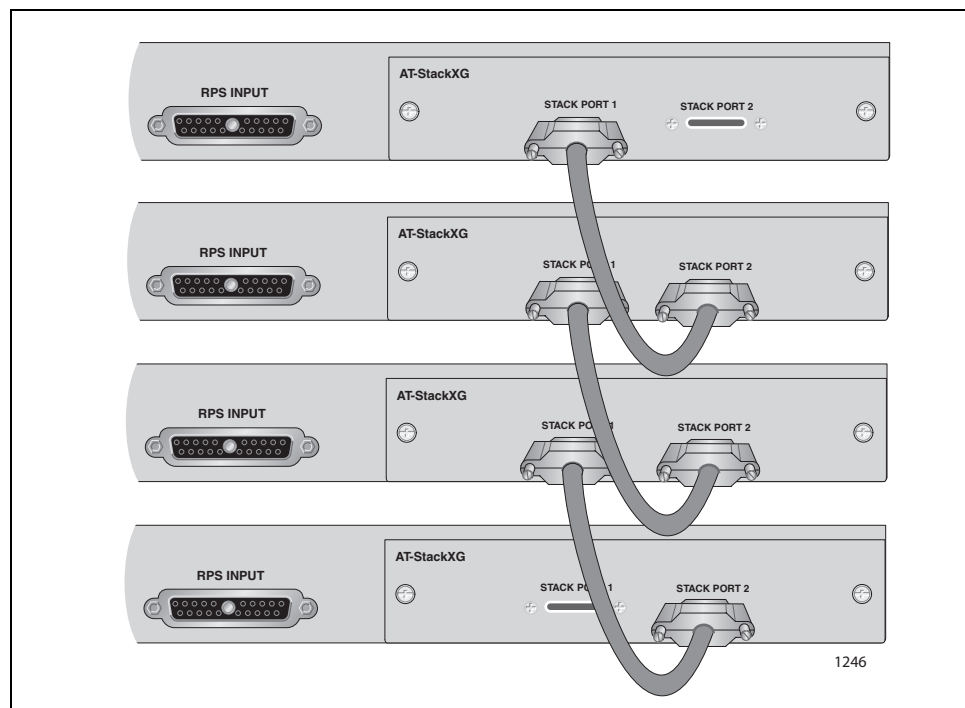

Figure 2. Duplex-chain Topology

The second topology, the duplex-ring topology, is identical to the daisy-chain, except that the stacking module in the switch at the top of the stack is connected to the stacking module in the switch at the bottom of the stack to form a physical loop. An example of this topology is shown in Figure 3.

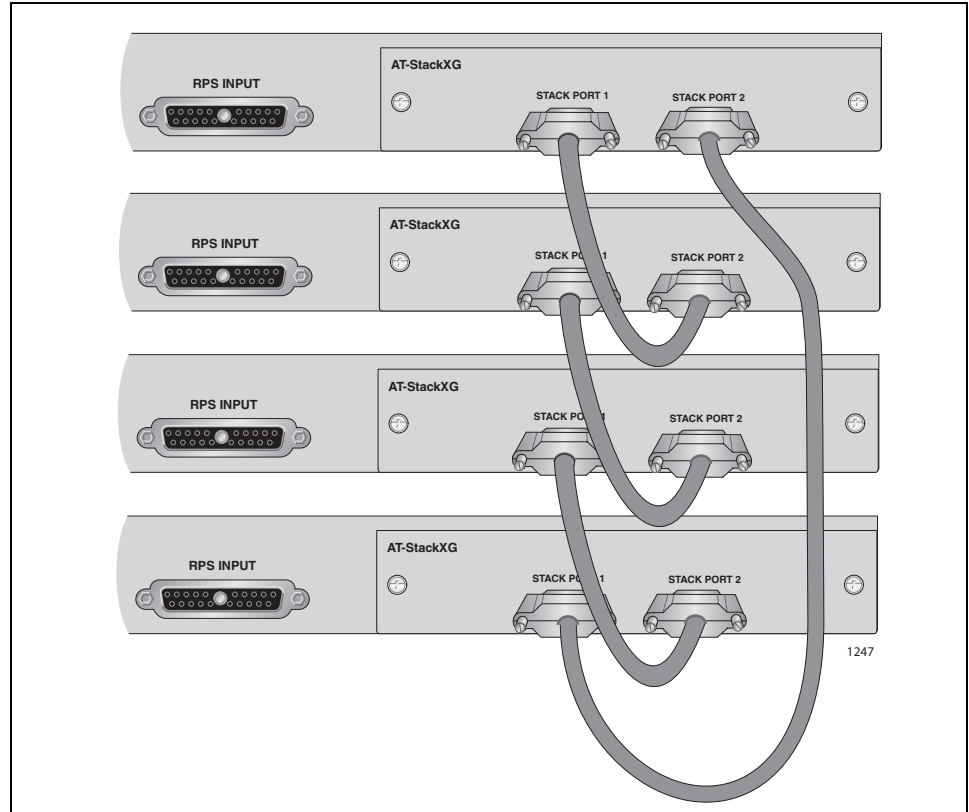

Figure 3. Duplex-ring Topology

Both topologies offer the same in terms of network speed and performance. But the duplex-ring topology adds redundancy by providing a secondary path through the stacking modules. This can protect a stack against the failure of a stacking port or cable. A disruption in the primary path automatically activates the secondary path.

## Discovery Process

---

When the switches of a stack are powered on or reset, they synchronize their operating software in a two phase process before they begin to forward network traffic through their ports.

In the first phase the switches initialize their AT-S63 Management Software. It takes about one minute for a switch to fully initialize its software.

In the second phase the switches determine the number of devices in the stack, the cabling topology of the stacking modules, and, in the case of the duplex-ring topology, the active path through the stacking modules. It is also in this phase that the master switch of the stack is identified and the parameter settings of the devices are configured with the commands in the active configuration file in the master switch's file system.

This second phase is referred to as the discovery process. The length of time of the discovery process can vary depending on a number of factors, like the number of switches in the stack, the switch models, and the number and complexity of the commands in the active configuration file on the master switch. For instance, a small stack of two switches might take less than fifteen seconds to complete the discovery process, while a stack of eight AT-9424Ts Switches might take several minutes.

When the discovery process is finished the switches of the stack begin to forward network traffic from their ports.

A stack will perform both phases whenever the switches are powered on or reset. However, a stack will automatically repeat the discovery phase whenever there is change to its topology or composition. For example, disconnecting a stacking cable from a stacking module, powering off a switch, or adding or removing a switch from the stack are all examples of events that will prompt a repetition of the discovery process.

Since the switches of a stack do not forward traffic during the discovery process, a change to a stack's topology will be disruptive to the activity of your network. Consequently, changes to the composition of a stack should be scheduled during periods of low network traffic to minimize the impact on your network.

## Master and Member Switches

---

The activities of the devices of a stack are coordinated by a master switch. There can be only one master switch, but it can be any unit in a stack. The master switch is assigned module ID 1, as explained in “Module ID Numbers” on page 70. This switch maintains the active configuration file, which contains the parameter settings for all of the switches in the stack.

The stack also has a backup master switch. This unit, which is assigned module ID 2, maintains a copy of the active configuration file and assumes the role of the master switch if the current master switch fails or is removed from the stack.

The other switches of a stack are called member switches.

## Module ID Numbers

---

The switches of a stack are identified by module ID numbers. Each switch must have its own unique number. The range is 1 to 8. The switches assigned the module ID numbers 1 and 2 become the master switch and the backup master switch of a stack, respectively.

The commands for managing the module ID numbers are `SET STACK` and `SHOW STACK`. The `SET STACK` command should only be used when a switch is functioning as a stand-alone device because there can be unpredictable results if you change a switch's module ID number when it is part of a stack.

The module ID numbers of the switches do not have to match the physical arrangement of the units in the stack. For example, any switch in a stack can be assigned module ID number 1 and so be the master switch. However, the units will be easier to identify if they are numbered in either ascending or descending order in the equipment rack.

After you have assigned the module ID numbers to the switches and begun to configure the parameter settings of a stack, you should not alter the number assignments. The boot configuration file on the master switch identifies the switches by their module ID numbers, and if you change the numbers the master switch could assign the wrong configurations to the switches the next time you reset or power on the stack.

Previous to version 4.0.0 of the AT-S63 Management Software, there were two ways to assign the numbers. One way was to assign them yourself. These were called static numbers because they didn't change if you added or removed switches from a stack. The other method was to let the management software assign the number based on the MAC addresses of the units. These numbers were called dynamic numbers because the numbers could change if switches were added or removed.

With version 4.0.0 and later Allied Telesis recommends only static numbers for the switches of a stack. The ID stack assignment of `AUTO`, used to assign dynamic numbers, should only be used when the AT-9400Ts Switches are used as stand-alone units.

## Stack Configuration Files

---

The parameter settings of a stack are stored in the active configuration file in the master switch's file system. The master switch restores the parameter settings in the file to the switches whenever the stack performs the discovery process, such as when you reset or a power cycle the stack, or add or remove a switch.

The master switch does not automatically update the active configuration file when you change a parameter setting on a stack device. Instead, you initiate the update with the `SAVE CONFIGURATION` command. In response, the master switch polls all of the devices in the stack for their current settings and updates the active configuration file. Since changes to the parameter settings that are not saved to the configuration file are discarded whenever the stack is reset or powered off, you should perform the `SAVE CONFIGURATION` command after configuring the devices if you want the stack to permanently retain your changes.

A backup copy of the master switch's active configuration file is stored in the file system in the switch assigned module ID 2. The backup configuration file is updated whenever the `SAVE CONFIGURATION` command is issued, and so is an exact duplicate of the active configuration file on the master switch.

Under normal operating conditions, the backup configuration file remains inactive. However, if the master switch stops operating or is removed from the stack, the switch assigned module ID 2 assumes the role of the master switch during the subsequent discovery process and configures the stack devices with its backup copy of the configuration file. If the original master switch resumes operations, it reassumes the master switch role after the discovery process and configures the stack with the active configuration file in its file system. The configuration file on the switch assigned module ID 2 reverts to its backup status.

The AT-9424Ts, AT-9424Ts/XP and AT-9448Ts/XP Switches have different configuration files for stand-alone and stack operations. The default files are `BOOT.CFG` for stand-alone operation and `STACK.CFG` for stack operation. The switches choose the appropriate file during the discovery process based on their stack ID numbers.

When a switch initializes its management software, such as when you power it on or reset it, it performs the discovery process and then checks its stack ID number. Here are the possibilities:

- ❑ If the number is set to `AUTO`, meaning automatic, the switch assumes that it is a stand-alone switch and uses the `BOOT.CFG` file, or whatever stand-alone file you've designated. This is the default setting for the switches.

- ❑ If the switch determines that its ID number is set to `STATIC` with the value 1, then it knows that it's the master switch of the stack and that it is responsible for maintaining the `STACK.CFG` file for the entire stack.
- ❑ If the switch determines that its ID number is set to `STATIC` with a value of 2 or more, then it knows that it is part of a stack and that it should receive its configure settings from the master switch.
- ❑ If the switch's ID number is set to `STATIC` but the device is not a part of a stack, the switch still uses the `STACK.CFG` file to set its parameter settings. If the switch does not have this file, it uses the default values for its parameter settings.

By having two standard configuration files, a switch can retain its prior configuration settings when converted from a stand-alone configuration to a stack member, or vice versa. This saves you the trouble of having to reconfigure the device.

Since there are two different configuration files, the parameter settings from a stand-alone configuration file cannot be automatically transferred to a stack configuration file. For a switch to have the same settings in a stack that it had as a stand-alone device, you must reapply the settings after adding the switch to the stack.



## MAC Address Tables

---

The MAC address tables of the switches in a stack are all the same. This is because the switches share their MAC addresses as they learn them. When a switch learns a new address on a port, it stores the address in its MAC address table and sends the address from the AT-StackXG Stacking Module to the other switches, which store the address in their tables.

When you view the MAC address table of a stack with the web browser windows, you can only view the table on the master switch. But since the tables in a stack are all the same, the master switch has the same table as all the other switches.

Viewing the MAC address table of a stack from the command line is a little different because you can select to view the table of a particular member switch, rather than the master switch. Why would this be useful if the tables in a stack are all the same? Delays can occur between when member switches learn new addresses and share them with the other units. This option lets you view addresses that member switches may have learned but haven't had a chance to share yet.

## File Systems

---

The file system on the master switch is the only accessible file system in a stack. The file systems on the member switches are not accessible.

## Compact Flash Memory Card Slots

---

The master switch of a stack has the only active compact flash memory slot. The slots in the member switches are inactive.

## Stack IP Address

---

If you do not intend to use the packet routing feature, you must still assign one routing interface to the stack if it will be performing any of the following management functions:

- ❑ Remote Telnet or web browser management
- ❑ Sending event messages to a syslog server
- ❑ Sending or receiving TCP/IP pings
- ❑ Uploading or downloading files to the master switch's file system from a TFTP server

To assign an IP address to the stack you have to create an IPv4 routing interface. The stack uses the routing interface's IP address as its address when performing the functions listed above.

Here are the general steps to assigning an IP address to the stack:

1. Create a virtual LAN (VLAN) on the stack. The VLAN must include the port(s) from where the stack will communicate with the remote servers or the Telnet or web browser clients. You can skip this step if you will be using the Default\_VLAN for the remote management sessions.
2. Add an IPv4 routing interface to the VLAN. If the IP addresses of the routing interface and the remote servers or Telnet clients are part of different subnets, the subnets must be connected with Layer 3 routing devices.
3. To manage the stack from a remote Telnet client, designate the routing interface as the stack's local interface with SET IP LOCAL INTERFACE command. This instructs the management software to monitor the subnet of the interface for the remote management packets from the Telnet client.

## Upgrading the AT-S63 Management Software

---

The AT-9400 Switch must have Version 3.0.0 or later of the AT-S63 Management Software to be a member of a stack.

To update the management software on an existing stack for versions after Version 3.0.0, you must disconnect the stacking cables and update the switches individually, either locally through the Terminal Port on the units or over the network using a TFTP server. You reconnect the stacking cables after the management software on all of the switches has been updated.

---

**Note**

The switches of a stack must use the same version of the management software.

---



## Chapter 3

# Enhanced Stacking

---

This chapter contains the following sections:

- ❑ “Supported Platforms” on page 78
- ❑ “Overview” on page 79
- ❑ “Master and Slave Switches” on page 80
- ❑ “Common VLAN” on page 81
- ❑ “Master Switch and the Local Interface” on page 82
- ❑ “Slave Switches” on page 83
- ❑ “Enhanced Stacking Compatibility” on page 84
- ❑ “Enhanced Stacking Guidelines” on page 85
- ❑ “General Steps” on page 86

## Supported Platforms

---

Table 29 and Table 30 list the AT-9400 Switches and the management interfaces that support enhanced stacking.

Table 29. Support for Enhanced Stacking

Switch	Supported
Layer 2+ Models	
AT-9408LC/SP	Yes
AT-9424T/GB	Yes
AT-9424T/SP	Yes
Basic Layer 3 Models	
AT-9424T	Yes
AT-9424T/POE	Yes
AT-9424Ts	Yes
AT-9424Ts/XP	Yes
AT-9448T/SP	Yes
AT-9448Ts/XP	Yes
AT-9400Ts Stack	

Table 30. Management Interfaces for Enhanced Stacking

Switch or Stack	Standard Command Line	AlliedWare Plus Command Line	Menus	Web Browser
Stand-alone Switch	Yes		Yes	Yes
AT-9400Ts Stack				

## Overview

---

Having to manage a large number of network devices typically involves starting a separate management session on each device. This usually means having to end one management session in order to start a new session on another unit.

The enhanced stacking feature can simplify this task because it allows you to easily transition among the different AT-9400 Switches in your network from just one management session. This reduces the need of having to end a management session when you need to manage another switch.

It should be noted that the individual switches of an enhanced stack continue to function as stand-alone switches and, as such, operate independently of each other. They do not form what is commonly referred to as a “virtual stack,” where the switches act as a logical unit.

---

**Note**

Starting with version 2.0.0 of the AT-S63 Management Software, several significant changes have been made to the implementation of the enhanced stacking feature. Allied Telesis recommends reviewing the information in this section before using this feature, even if you are familiar with it from earlier versions of the AT-S63 Management Software or from other Allied Telesis Ethernet switches that support this feature.

---

## Master and Slave Switches

---

An enhanced stack must have at least one master switch. This switch is your management access point to the switches of a stack. After you have started a local or remote management session on a master switch, you can redirect the session to any of the other switches.

The other switches in the stack are known as slave switches. They can be managed through the master switch or directly, such as from a local management session.

An enhanced stack can have more than one master switch. Multiple master switches can lessen the impact on your network management should you need to remove a master switch from the network, such as for maintenance purposes.



## Common VLAN

---

A master switch searches for the other switches in an enhanced stack by sending out a broadcast packet out a local subnet. (The designation of this subnet is explained in “Master Switch and the Local Interface,” next.) Since a broadcast packet cannot cross a router or a VLAN boundary, you must connect the switches of an enhanced stack with a common VLAN. The VLAN acts as the transfer path for the broadcast packets from the master switch to the slave switches and also serves as the path for other management packets.

Here are several things to keep in mind as you plan the common VLAN of your enhanced stack:

- ❑ Any valid VLAN name and VLAN identifier (VID) can be used for the common VLAN, but it should be the same on all the switches in the stack.
- ❑ A slave switch of an enhanced stack can be indirectly connected to the master switch through other switches, provided there is an uninterrupted path of the common VLAN from the slave switch to the master switch.
- ❑ The Default\_VLAN can be used as the common VLAN.
- ❑ The common VLAN does not have to be dedicated solely to the enhanced stacking feature.

For background information on port-based and tagged virtual LANs, refer to “Overview” on page 271.

## Master Switch and the Local Interface

---

Before a switch can function as the master switch of an enhanced stack, it needs to know which subnet is acting as the common subnet among the switches in the stack. It uses that information to know which subnet to send out its broadcast packets and to monitor for the management packets from the other switches and from remote management workstations.

Designating the common VLAN and subnet involves creating a routing interface on the master switch on the common subnet and designating it as the local interface. The concept of routing interfaces first appeared in the AT-9400 Switch with Layer 3 routing and the implementation of static routing and the Routing Information Protocol (RIP) version 1 and 2.

An interface represents a logical connection to a network or subnet local to the switch for purposes of routing packets. To configure an interface, you assign it an IP address and subnet mask appropriate to the subnet where it will route packets, and add it to the VLAN that contains the subnet.

For the most part, routing interfaces are limited to the IPv4 packet routing feature and are unnecessary beyond that feature. There are, however, a few exceptions. One is the enhanced stacking feature. The rule is that the master switch of an enhanced stack must have at least one interface and the interface must be assigned to the common subnet that interconnects the switches of the stack. Furthermore, the interface must be designated as the switch's local interface. The act of designating an interface as the local interface tells the switch which interface and which subnet it should use for the enhanced stacking feature.

For background information on the IPv4 routing feature, refer Chapter 29, "Internet Protocol Version 4 Packet Routing" on page 321.

## Slave Switches

---

The slave switches of an enhanced stack must be connected to the master switch through a common VLAN. A slave switch can be connected indirectly to the master switch so long as there is an uninterrupted path of the common VLAN from the slave switch to the master switch.

A slave switch does not need a routing interface on the common VLAN if you use the Default\_VLAN (VID 1) as the common VLAN. A routing interface in the common VLAN is required if you use any other VLAN other than the Default\_VLAN as the common VLAN of the switches in the stack.

The routing interface in the common VLAN on a slave switch does not have to be designated as the local interface. The only circumstance in which you might want to designate a local interface on a slave switch is if you want to be able to remotely manage the device independently of the enhanced stack. However, for the switch to remain part of an enhanced stack, the interface designated as the local interface must be in the common VLAN.

## Enhanced Stacking Compatibility

---

This version of enhanced stacking is compatible with earlier AT-S63 versions and the enhanced stacking feature in the AT-8400 Series and AT-8500 Series Switches. As such, an enhanced stack can consist of various switch models, though the following issues need to be considered when building this type of enhanced stack:

- ❑ The management VLAN of an AT-8400 Series or AT-8500 Series Switch must be assigned to the common VLAN that interconnects the switches of the stack. For instructions on how to select the management VLAN on an AT-8400 Series or AT-8500 Series Switch, refer to the appropriate user's guide.
- ❑ Though the master switch of an enhanced stack can be any switch that supports this feature, Allied Telesis recommends choosing the AT-9400 Switch to perform that role. To use an AT-8400 Series or AT-8500 Series Switch as the master switch, you must assign it an IP address that is part of the same common subnet that interconnects the switches of the stack. For instructions on how to assign an IP address to an AT-8400 Series or AT-8500 Series Switch, refer to the appropriate user's guide.

## Enhanced Stacking Guidelines

---

Here are the guidelines to using the enhanced stacking feature:

- ❑ There can be up to 24 switches in an enhanced stack.
- ❑ The switches in an enhanced stack must be connected with a common port-based or tagged VLAN. The VLAN must have the same name and VLAN identifier (VID) on each switch, and the switches must be connected using tagged or untagged ports of the VLAN.
- ❑ A slave switch can be connected indirectly to the master switch through other switches so long as there is an uninterrupted path of the common VLAN from the master switch to the slave switch.
- ❑ You must add a routing interface to the common VLAN on the master switch and designate it as the master switch's local interface.
- ❑ You do not need to create a routing interface in the common VLAN on the slave switches if you use the Default\_VLAN (VID 1) as the common VLAN of the switches of a stack. However, a routing interface is required if you use any other VLAN as the common VLAN. However, you do not have to designate it as the local interface.
- ❑ You can create different stacks by connecting different groups of switches with different common VLANs and subnets.
- ❑ An enhanced stack must have at least one master switch. You designate the master by changing its stacking status to Master.
- ❑ An enhanced stack can consist of other Allied Telesis switches that support this feature, including the AT-8400, AT-8500, and AT-9400 Switches. For more information, refer to "Enhanced Stacking Compatibility" on page 84.
- ❑ In order to manage the stack remotely using a Telnet or SSH client or a web browser, the remote management workstation must reach the master switch through the subnet of the switch's local interface.
- ❑ The IP address 172.16.16.16 is reserved for the enhanced stacking feature and must not be assigned to any device on your network.

## General Steps

---

Here are the basic steps to implementing the enhanced stacking feature on the AT-9400 Switches in your network:

1. Select a switch to act as the master switch of the enhanced stack. This can be any Allied Telesis switch that supports this feature. In a stack with different switch models, Allied Telesis recommends using an AT-9400 Switch as the master switch. For further information, refer to “Enhanced Stacking Compatibility” on page 84.
2. On the switch chosen to be the master switch, change its stacking status to Master.
3. Create a common port-based or tagged VLAN on each switch and connect the devices using twisted pair or fiber optic ports of the VLAN. As mentioned earlier, the slaves switches can be connected indirectly through other switches to the master switch, so long as there is an uninterrupted path of the common VLAN to the master switch. This step is not necessary if you use the Default\_VLAN (VID 1) as the common VLAN.
4. On the master switch, assign a routing interface to the common VLAN.
5. On the master switch designate the interface assigned to the common VLAN as the local interface.
6. On the slave switches, add a routing interface to the common VLAN. You do not need to designate it as the local interface. This step is not necessary if you use the Default\_VLAN (VID 1) as the common VLAN.

---

### **Note**

The initial configuration of the enhanced stacking feature on a master switch must be performed through a local management session.

---

## Chapter 4

# SNMPv1 and SNMPv2c

---

This chapter describes SNMPv1 and SNMPv2c community strings for SNMP management of the switch. Sections in the chapter include:

- ❑ “Supported Platforms” on page 88
- ❑ “Overview” on page 89
- ❑ “Community String Attributes” on page 90
- ❑ “Default SNMP Community Strings” on page 92

## Supported Platforms

---

Refer to Table 31 and Table 32 for the AT-9400 Switches and the management interfaces that support SNMPv1 and SNMPv2c community strings.

Table 31. Support for SNMPv1 and SNMPv2c Community Strings

Switch	Supported
Layer 2+ Models	
AT-9408LC/SP	Yes
AT-9424T/GB	Yes
AT-9424T/SP	Yes
Basic Layer 3 Models	
AT-9424T	Yes
AT-9424T/POE	Yes
AT-9424Ts	Yes
AT-9424Ts/XP	Yes
AT-9448T/SP	Yes
AT-9448Ts/XP	Yes
AT-9400Ts Stack	Yes

Table 32. Management Interfaces for SNMPv1 and SNMPv2c Community Strings

Switch or Stack	Standard Command Line	AlliedWare Plus Command Line	Menus	Web Browser
Stand-alone Switch	Yes		Yes	Yes
AT-9400Ts Stack	Yes			Yes



## Overview

---

You can manage a switch by viewing and changing the management information base (MIB) objects on the device with the Simple Network Management Program (SNMP). The AT-S63 Management Software supports SNMPv1, SNMPv2c, and SNMPv3. This chapter explains SNMPv1 and SNMPv2c. For information on SNMPv3, refer to Chapter 21, "SNMPv3" on page 219.

To manage a switch using an SNMP application program, you must do the following:

- ❑ Activate SNMP management on the switch. The default setting for SNMP management is disabled.
- ❑ Load the Allied Telesis MIBs for the switch onto your management workstation containing the SNMP application program. The MIBs are available from the Allied Telesis web site at [www.alliedtelesis.com](http://www.alliedtelesis.com).

To manage a switch using SNMP, you need to know the IP address of the switch or of the master switch of an enhanced stack and at least one of the switch's community strings.

You can configure SNMPv1 and SNMPv2c with the SNMPv3 Table menus described in Chapter 21, "SNMPv3" on page 219. However, the SNMPv3 Table menus require a much more extensive configuration.

## Community String Attributes

---

A community string has attributes for controlling who can use the string and what the string will allow a network management to do on the switch. The community string attributes are defined below:

### Community String Name

A community string must have a name of one to eight alphanumeric characters. Spaces are allowed.

### Access Mode

This attribute defines the permissions of a community string. There are two access modes: Read and Read/Write. A community string with an access mode of Read can only be used to view but not change the MIB objects on a switch. A community string with a Read/Write access can be used to both view the MIB objects and change them.

### Operating Status

A community string can be enabled or disabled. When disabled, no one can use it to access the switch. You might disable a community string if you suspect someone is using it for unauthorized access to the device. When a community string is enabled, then it is available for use.

### Open or Closed Access Status

This feature controls which management stations on your network can use a community string. An open access status permits any network manager who knows the community string to use it. A closed access status restricts the string to those network managers who work at particular workstations, identified by their IP addresses. You specify the workstations by assigning the IP addresses of the workstations to the community string. A closed community string can have up to eight IP addresses of management workstations.

If you decide to activate SNMP management on the switch, it is a good idea to assign a closed status to all community strings that have a Read/Write access mode and then assign the IP addresses of your management workstations to those strings. This helps reduce the chance of someone gaining management access to a switch through a community string and making unauthorized configuration changes.

### Trap Receivers

A trap is a signal sent to one or more management workstations by the switch to indicate the occurrence of a particular operating event on the device. There are numerous operating events that can trigger a trap. For instance, resetting the switch or the failure of a cooling fan are two examples of occurrences that cause a switch to send a trap to the management workstations. You can use traps to monitor activities on the switch.

Trap receivers are the devices, typically management workstations or servers, that you want to receive the traps sent by the switch. You specify the trap receivers by their IP addresses. You assign the IP addresses to

the community strings.

Each community string can have up to eight trap IP addresses.

It does not matter which community strings you assign your trap receivers. When the switch sends a trap, it looks at all the community strings and sends the trap to all trap receivers on all community strings. This is true even for community strings that have a access mode of only Read.

If you are not interested in receiving traps, then you do not need to enter any IP addresses of trap receivers.

## Default SNMP Community Strings

---

The AT-S63 Management Software provides two default community strings: public and private. The public string has an access mode of just Read and the private string has an access mode of Read/Write. If you activate SNMP management on the switch, you should delete or disable the private community string, which is a standard community string in the industry, or change its status from open to closed to prevent unauthorized changes to the switch.

## Chapter 5

# MAC Address Table

---

This chapter contains background information about the MAC address table. This chapter contains the following section:

- “Overview” on page 94

## Overview

---

The AT-9400 Switch has a MAC address table with a storage capacity of 16,000 entries. The table stores the MAC addresses of the network nodes connected to its ports and the port numbers where the addresses were learned.

A switch learns the MAC addresses of the end nodes by examining the source addresses of the packets received on a port. It adds to the MAC table the addresses along with the ports on which the packets were received. The result is a table of all the MAC addresses of the devices that are connected to a switch's ports.

When a switch receives a packet, it also examines the destination address and, by referring to its MAC address table, determines the port where the destination node is connected. It then forwards the packet to the appropriate port and on to the end node. This increases network bandwidth by limiting each frame to the appropriate port when the destination end node is located, freeing the other switch ports for receiving and transmitting other packets.

If a switch receives a packet with a destination address that is not in the MAC address table, it floods the packet to all of its ports, excluding the port where the packet was received. If the ports have been grouped into virtual LANs, a switch floods the packet only to those ports that belong to the same VLAN from where the packet originated. This prevents packets from being forwarded to inappropriate LAN segments and increases network security. When the destination node responds, a switch adds its MAC address and port number to its MAC address table.

If a switch receives a packet with a destination address that is on the same port on which the packet was received, it discards the packet without forwarding it on to any port. Because both the source node and the destination node for the packet are located on the same port on the switch, there is no reason for the switch to forward the packet. This too increases network performance by preventing frames from being forwarded unnecessarily to other network devices.

The type of MAC address described above is referred to as a *dynamic MAC address*. Dynamic MAC addresses are addresses that the switch learns by examining the source MAC addresses of the frames received on the ports.

Dynamic MAC addresses are not stored indefinitely in the MAC address table. A switch deletes a dynamic MAC address from the table if it does not receive any frames from the node after a specified period of time. A switch assumes that the node with that MAC address is no longer active and that its MAC address can be purged from the table. This prevents the MAC address table from becoming filled with addresses of nodes that are

no longer active.

The period of time a switch waits before purging inactive dynamic MAC addresses is called the *aging time*. This value is adjustable on the AT-9400 Switch. The default value is 300 seconds (5 minutes).

The MAC address table can also store *static MAC addresses*. These are addresses of end nodes you enter manually into the MAC address table. Static MAC addresses remain in the table indefinitely and are never deleted, even when the end nodes are inactive.

You might need to enter static MAC addresses of end nodes the switch does not learn in its normal dynamic learning process, or if you want a MAC address to remain permanently in the table, even when the end node is inactive.





## Chapter 6

# Static Port Trunks

---

This chapter describes static port trunks. Sections in the chapter include:

- ❑ “Supported Platforms” on page 98
- ❑ “Overview” on page 99
- ❑ “Load Distribution Methods” on page 100
- ❑ “Guidelines” on page 102

## Supported Platforms

---

Refer to Table 33 and Table 34 for the AT-9400 Switches and the management interfaces that support static port trunks.

Table 33. Support for Static Port Trunks

Switch	Supported
Layer 2+ Models	
AT-9408LC/SP	Yes
AT-9424T/GB	Yes
AT-9424T/SP	Yes
Basic Layer 3 Models	
AT-9424T	Yes
AT-9424T/POE	Yes
AT-9424Ts	Yes
AT-9424Ts/XP	Yes
AT-9448T/SP	Yes
AT-9448Ts/XP	Yes
AT-9400Ts Stack	Yes

Table 34. Management Interfaces for Static Port Trunks

Switch or Stack	Standard Command Line	AlliedWare Plus Command Line	Menus	Web Browser
Stand-alone Switch	Yes	Yes	Yes	Yes
AT-9400Ts Stack	Yes	Yes		Yes

## Overview

---

A static port trunk is a group of two to eight ports that function as a single virtual link between the switch and another device. Traffic is distributed across the ports to improve performance and enhance reliability by reducing the reliance on a single physical link.

A static port trunk is easy to configure. You simply designate the ports of the trunk and the management software automatically groups them together. You can also control how traffic is distributed over the trunk ports, as described in “Load Distribution Methods” on page 100. The example in Figure 4 illustrates a static port trunk of four links between two AT-9400 Switches.

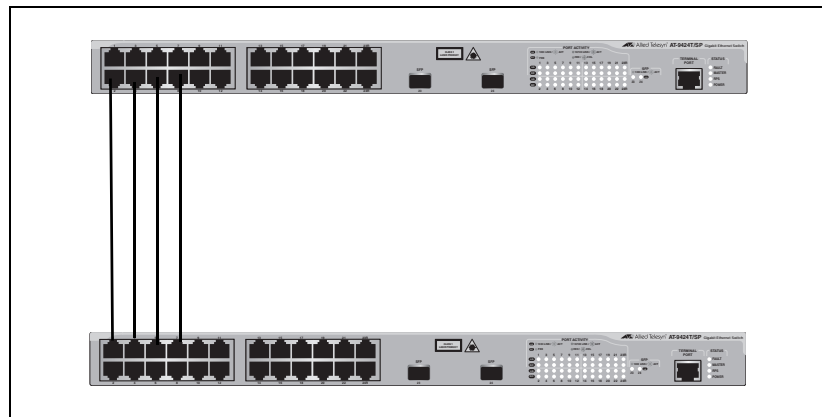

Figure 4. Static Port Trunk Example

Unlike LACP trunks, described in Chapter 7, “LACP Port Trunks” on page 103, static port trunks do not permit standby ports. If a link is lost on a port in a static port trunk, the trunk’s total bandwidth is reduced. Although the traffic carried by the lost link is shifted to one of the remaining ports in the trunk, the bandwidth remains reduced until the lost link is reestablished or another port is manually added to the trunk.

Network equipment vendors tend to employ different techniques for static trunks on their products. Consequently, a static trunk on one device might not be compatible with the same feature on a device from a different manufacturer. For this reason, static trunks are typically employed only between devices from the same vendor.

## Load Distribution Methods

---

This section discusses the load distribution methods of static port trunks and LACP port trunks, described in Chapter 7, “LACP Port Trunks” on page 103.

When you create a static or LACP port trunk, you have to select a load distribution method that controls how the switch is to distribute the traffic load across the ports in the trunk. The AT-S63 Management Software offers the following load distribution methods:

- Source MAC Address (Layer 2)
- Destination MAC Address (Layer 2)
- Source MAC Address / Destination MAC Address (Layer 2)
- Source IP Address (Layer 3)
- Destination IP Address (Layer 3)
- Source IP Address / Destination IP Address (Layer 3)

The load distribution methods examine the last three bits of a packet’s MAC or IP address and compare the bits against mappings assigned to the ports in the trunk. The port mapped to the matching bits is selected as the transmission port for the packet.

In cases where you select a load distribution that employs either a source or destination address but not both, only the last three bits of the designated address are used in selecting a transmission port in a trunk. If you select one of the two load distribution methods that employs both source and destination addresses, port selection is achieved through an XOR operation of the last three bits of both addresses.

As an example, assume you created a static or LACP aggregate trunk of Ports 7 to 14 on a switch. The table below shows the mappings of the switch ports to the possible values of the last three bits of a MAC or IP address.

Last 3 Bits	000 (0)	001 (1)	010 (2)	011 (3)	100 (4)	101 (5)	110 (6)	111 (7)
Trunk Ports	7	8	9	10	11	12	13	14

Assume you selected source MAC address as the load distribution method and that the switch needed to transmit over the trunk a packet with a source MAC address that ended in 9. The binary equivalent of 9 is 1001, making the last three bits of the address 001. An examination of the table above indicates that the switch would use Port 8 to transmit the frame because that port is mapped to the matching bits.

A similar method is used for the two load distribution methods that employ both the source and destination addresses. Only here the last three bits of both addresses are combined by an XOR process to derive a single value which is then compared against the mappings of the bits to ports. The XOR rules are as follows:

0 XOR 0 = 0  
0 XOR 1 = 1  
1 XOR 0 = 1  
1 XOR 1 = 0

As an example, assume you selected source and destination MAC addresses for the load distribution method in our previous example, and that a packet for transmission over the trunk had a source MAC address that ended in 9 and a destination address that ended in 3. The binary values would be:

9 = 1001  
3 = 0011

Applying the XOR rules above on the last three bits would result in 010, or 2. A examination of the table above shows that the packet would be transmitted from port 9.

Port trunk mappings on the AT-9400 Switch can consist of up to eight ports. This corresponds to the maximum number of ports allowed in a static trunk and the maximum number of active ports in an LACP trunk. Inactive ports in an LACP trunk are not applied to the mappings until they transition to the active status.

You can assign different load distribution methods to different static trunks on the same switch. The same is true for LACP aggregators. However, it should be noted that all aggregate trunks within an LACP aggregator must use the same load distribution method.

The load distribution methods assume that the final three bits of the source and/or destination addresses of the packets from the network nodes are varied enough to support efficient distribution of the packets over the trunk ports. A lack of variation can result in one or more ports in a trunk being used more than others, with the potential loss of a trunk's efficiency and performance.

## Guidelines

---

Here are the guidelines to static trunks:

- ❑ Allied Telesis recommends limiting static port trunks to Allied Telesis network devices to ensure compatibility.
- ❑ A static trunk can have up to eight ports.
- ❑ Stand-alone switches and AT-9400Ts Stacks can support up to six static and LACP trunks at a time (for example, four static trunks and two LACP trunks). An LACP trunk is countered against the maximum number of trunks only when it is active.
- ❑ The ports of a static trunk must be of the same type of either twisted pair or fiber optic ports.
- ❑ The ports of a trunk can be either consecutive (for example Ports 5-9) or nonconsecutive (for example, ports 4, 8, 11, 20).
- ❑ The ports of static port trunks on stand-alone switches or switches in an enhanced stack must be from the same switch.
- ❑ The ports of a static port trunk in a stack of AT-9400 Basic Layer 3 Switches and the AT-StackXG Stacking Module can be from different switches in the same stack.
- ❑ Before creating a port trunk, examine the speed, duplex mode, flow control, and back pressure settings of the lowest number port to be in the trunk. Verify that its settings are correct for the device to which the trunk will be connected. When you create a static port trunk, the management software copies the current settings of the lowest numbered port in the trunk to the other ports, because all ports in a static trunk must have the same settings. For example, if you create a port trunk consisting of ports 5 to 8, the parameter settings for port 5 are copied to ports 6, 7, and 8 so that all the ports of the trunk have the same settings.
- ❑ After creating a port trunk, do not change the speed, duplex mode, flow control, or back pressure of any port in the trunk without also changing the other ports.
- ❑ A port can belong to only one static trunk at a time.
- ❑ A port cannot be a member of a static trunk and an LACP trunk at the same time.
- ❑ The ports of a static trunk must be untagged members of the same VLAN. A trunk cannot consist of untagged ports from different VLANs.
- ❑ The switch selects the lowest numbered port in the trunk to handle broadcast packets and packets of unknown destination. For example, a trunk of ports 11 to 15 would use port 11 for broadcast packets.

## Chapter 7

# LACP Port Trunks

---

This chapter explains Link Aggregation Control Protocol (LACP) port trunks. Sections in the chapter include:

- ❑ “Supported Platforms” on page 104
- ❑ “Overview” on page 105
- ❑ “LACP System Priority” on page 106
- ❑ “Adminkey Parameter” on page 107
- ❑ “LACP Port Priority Value” on page 107
- ❑ “Load Distribution Methods” on page 108
- ❑ “Guidelines” on page 109

## Supported Platforms

---

Refer to Table 35 and Table 36 for the AT-9400 Switches and the management interfaces that support LACP port trunks.

Table 35. Support for LACP Port Trunks

Switch	Supported
Layer 2+ Models	
AT-9408LC/SP	Yes
AT-9424T/GB	Yes
AT-9424T/SP	Yes
Basic Layer 3 Models	
AT-9424T	Yes
AT-9424T/POE	Yes
AT-9424Ts	Yes
AT-9424Ts/XP	Yes
AT-9448T/SP	Yes
AT-9448Ts/XP	Yes
AT-9400Ts Stack	Yes

Table 36. Management Interfaces for LACP Port Trunks

Switch or Stack	Standard Command Line	AlliedWare Plus Command Line	Menus	Web Browser
Stand-alone Switch	Yes	Yes	Yes	
AT-9400Ts Stack	Yes	Yes		



## Overview

---

LACP (Link Aggregation Control Protocol) port trunks perform the same function as static trunks. They increase the bandwidth between network devices by distributing the traffic load over multiple physical links. The advantage of an LACP trunk over a static port trunk is its flexibility. While implementations of static trunking tend to be vendor specific, the implementation of LACP in the AT-S63 Management Software is compliant with the IEEE 802.3ad standard, making it interoperable with equipment from other vendors that also comply with the standard. Therefore, you can create an LACP trunk between an Allied Telesis device and network devices from other manufacturers.

Another advantage is that ports in an LACP trunk can function in a standby mode. This adds redundancy and resiliency to the trunk. If a link in a static trunk goes down, the overall bandwidth of the trunk is reduced until the link is reestablished or another port is added to the trunk. In contrast, an LACP trunk can automatically activate ports in a standby mode when an active link fails so that the maximum possible bandwidth of the trunk is maintained.

For example, assume you create an LACP trunk of ports 11 to 20 on a switch and the switch is using ports 11 to 18 as the active ports and ports 19 and 20 as reserve. If an active port loses its link, the switch automatically activates one of the reserve ports to maintain maximum bandwidth of the trunk.

The main component of an LACP trunk is an *aggregator*. An aggregator is a group of ports on the switch. The ports in an aggregator are further grouped into a trunk, referred to as an *aggregate trunk*.

An aggregate trunk can consist of any number of ports on a switch, but only a maximum of eight ports can be active at a time. If an aggregate trunk contains more ports than can be active at one time, the extra ports are placed in a standby mode. Ports in the standby mode do not pass network traffic, but they do transmit and accept LACP data unit (LACPDU) packets, which the switch uses to search for LACP-compliant devices.

Only ports on a switch that are part of an aggregator transmit LACPDU packets. If a switch port that is part of an aggregator does not receive LACPDU packets from its corresponding port on the other device, it assumes that the other port is not part of an LACP trunk. Instead, it functions as a normal Ethernet port by forwarding network traffic. However, it does continue to send LACPDU packets. If it begins to receive LACPDU packets, it automatically transitions to an active or standby mode as part of an aggregate trunk.

An aggregator can have only one trunk. If a switch will have more than one aggregate trunk, you have to create a separate aggregator for each trunk.

## LACP System Priority

---

It is possible for two devices interconnected by an aggregate trunk to encounter a conflict when they form the trunk. For example, the two devices might not support the same number of active ports in an aggregate trunk or might not agree on which ports are to be active and which are to be in standby.

If a conflict does occur, the two devices need a mechanism for resolving the problem and deciding whose LACP settings are to take precedence. This is the function of the system LACP priority value. A hexadecimal value of from 1 to FFFF, this parameter is used whenever the devices encounter a conflict creating a trunk. The lower the number, the higher the priority. The settings on the device with the higher priority take precedence over the settings on the other device. If both devices have the same system LACP priority value, the settings on the switch with the lowest MAC address take precedence.

This parameter can prove useful when connecting an aggregate trunk between the AT-9400 Switch and another 802.3ad-compliant device that does not have the same LACP trunking capabilities. If the other device's capability is less than that of the AT-9400 Switch, you should give that device the higher priority so its settings are used by both devices when forming the trunk.

For example, an aggregate trunk of six links between an AT-9400 Switch and an 802.3ad-compliant device that supported up to four active links at one time could possibly result in a conflict. The AT-9400 Switch would try to use all six links as active, because it can handle up to eight active links in a trunk at one time, while the other device would want to use only four ports as active. By giving the other 802.3ad device the higher priority, the conflict is avoided because the AT-9400 Switch would use only four active links, as directed by the other 802.3ad-compliant device. The other ports would remain in the standby mode.

## Adminkey Parameter

---

The *adminkey* is a hexadecimal value from 1 to FFFF that identifies an aggregator. Each aggregator on a switch must have a unique adminkey. The adminkey is restricted to a switch. Two aggregators on different switches can have the same adminkey without generating a conflict.

## LACP Port Priority Value

---

The switch uses a port's LACP priority to determine which ports are to be active and which in the standby mode in situations where the number of ports in the aggregate trunk exceeds the highest allowed number of active ports. This parameter is a hexadecimal value in a range of 1 to FFFF, based on the port number. For instance, the priority values for ports 2 and 11 are 0002 and 000B, respectively. The lower the number, the higher the priority. Ports with the highest priorities are designated as the active ports in an aggregate trunk.

For example, if both 802.3ad-compliant devices support up to eight active ports and there are a total of ten ports in the trunk, the eight ports with the highest priorities (lowest priority values) are designated as the active ports, and the others are placed in the standby mode. If an active link goes down on a active port, the standby port with the next highest priority is automatically activated to take its place.

The selection of the active links in an aggregate trunk is dynamic and will change as links are added, removed, lost or reestablished. For example, if an active port loses its link and is replaced by another port in the standby mode, the reestablishment of the link on the originally active port causes the port to return to the active state by virtue of having a higher priority value than the replacement port, which returns to the standby mode.

A port's priority value is not adjustable.

Two conditions must be met in order for a port in an aggregate trunk to function in the standby mode. First, the number of ports in the trunk must exceed the highest allowed number of active ports and, second, the port must be receiving LACPDU packets from the other device. A port functioning in the standby mode does not forward network traffic, but does continue to send LACPDU packets. If a port that is part of an aggregator does not receive LACPDU packets, it functions as a normal Ethernet port and forwards network packets along with LACPDU packets.

## Load Distribution Methods

---

The load distribution method determines the manner in which the switch distributes the traffic across the active ports of an aggregate trunk. The method is assigned to an aggregator and applies to all aggregate trunks within it. If you want to assign different load distribution methods to different aggregate trunks, you must create a separate aggregator for each trunk. For further information, refer to “Load Distribution Methods” on page 100.

## Guidelines

---

The following guidelines apply to creating aggregators:

- ❑ LACP must be activated on both the switch and the other device.
- ❑ The other device must be 802.3ad-compliant.
- ❑ An aggregator can consist of any number of ports.
- ❑ The AT-S63 Management Software supports up to eight active ports in an aggregate trunk at a time.
- ❑ Stand-alone switches and AT-9400Ts Stacks can support up to six static and LACP aggregate trunks at a time (for example, four static trunks and two LACP trunks). An LACP trunk is countered against the maximum number of trunks only when it is active.
- ❑ The ports of an aggregate trunk must be the same medium type: all twisted pair ports or all fiber optic ports.
- ❑ The ports of a trunk can be consecutive (for example ports 5-9) or nonconsecutive (for example, ports 4, 8, 11, 20).
- ❑ A port can belong to only one aggregator at a time.
- ❑ A port cannot be a member of an aggregator and a static trunk at the same time.
- ❑ The ports of an aggregate trunk must be untagged members of the same VLAN.
- ❑ 10/100/1000Base-TX twisted pair ports must be set to Auto-Negotiation or 100 Mbps, full-duplex mode. LACP trunking is not supported in half-duplex mode.
- ❑ 100Base-FX fiber optic ports must be set to full-duplex mode.
- ❑ You can create an aggregate trunk of transceivers with 1000Base-X fiber optic ports.
- ❑ Only those ports that are members of an aggregator transmit LACPDU packets.
- ❑ The load distribution method is applied at the aggregator level. To assign different load distribution methods to aggregate trunks, you must create a separate aggregator for each trunk. For further information, refer to “Load Distribution Methods” on page 100.
- ❑ A member port of an aggregator functions as part of an aggregate trunk only if it receives LACPDU packets from the remote device. If it does not receive LACPDU packets, it functions as a regular Ethernet port, forwarding network traffic while also continuing to transmit LACPDU packets.
- ❑ The port with the highest priority in an aggregate trunk carries broadcast packets and packets with an unknown destination.

- ❑ When creating a new aggregator, you can specify either a name for the aggregator or an adminkey, but not both. If you specify a name, the adminkey is based on the operator key of the lowest numbered port in the aggregator. If you specify an adminkey, the default name is DEFAULT\_AGG followed by the port number of the lowest numbered port in the aggregator. For example, an aggregator of ports 12 to 16 is assigned the default name DEFAULT\_AGG12.
- ❑ Prior to creating an aggregate trunk between an Allied Telesis device and another vendor's device, refer to the vendor's documentation to determine the maximum number of active ports the device can support in a trunk. If the number is less than eight, the maximum number for the AT-9400 Switch, you should probably assign it a higher system LACP priority than the AT-9400 Switch. If it is more than eight, assign the AT-9400 Switch the higher priority. This can help avoid a possible conflict between the devices if some ports are placed in the standby mode when the devices create the trunk. For background information, refer to "LACP System Priority" on page 106.
- ❑ LACPDU packets are transmitted as untagged packets.

## Chapter 8

# Port Mirror

---

This chapter explains the port mirror feature. Sections in the chapter include:

- ❑ “Supported Platforms” on page 112
- ❑ “Overview” on page 113
- ❑ “Guidelines” on page 113

## Supported Platforms

---

Refer to Table 37 and Table 38 for the AT-9400 Switches and the management interfaces that support the port mirror.

Table 37. Support for the Port Mirror

Switch	Supported
Layer 2+ Models	
AT-9408LC/SP	Yes
AT-9424T/GB	Yes
AT-9424T/SP	Yes
Basic Layer 3 Models	
AT-9424T	Yes
AT-9424T/POE	Yes
AT-9424Ts	Yes
AT-9424Ts/XP	Yes
AT-9448T/SP	Yes
AT-9448Ts/XP	Yes
AT-9400Ts Stack	Yes

Table 38. Management Interfaces for the Port Mirror

Switch or Stack	Standard Command Line	AlliedWare Plus Command Line	Menus	Web Browser
Stand-alone Switch	Yes	Yes	Yes	Yes
AT-9400Ts Stack	Yes	Yes		Yes



## Overview

---

The port mirror feature allows for the unobtrusive monitoring of ingress or egress traffic on one or more ports on a switch, without impacting network performance or speed. It copies the traffic from specified ports to another switch port where the traffic can be monitored with a network analyzer.

The port(s) whose traffic is mirrored is called the *source port(s)*. The port where the traffic is copied to is referred to as the *destination port*.

## Guidelines

---

Observe the following guidelines when creating a port mirror:

- ❑ A standalone switch can have only one destination port.
- ❑ An AT-9400Ts Stack can have only one destination port.
- ❑ You can mirror more than one source port at a time. However, the destination port may have to discard packets if the source ports are very active.
- ❑ The source and destination ports for a port mirror on a stand-alone switch must be located on the same switch.
- ❑ The destination and source ports for a port mirror in an AT-9400Ts Stack can be located on different switches in the same stack.
- ❑ You can mirror the ingress or egress traffic of the source ports, or both.
- ❑ To create a mirror port for the Denial of Service defenses, specify only the destination port for the mirrored traffic. The management software automatically determines the source ports.



## Section II

# Advanced Operations

---

This section contains the following chapters:

- ❑ Chapter 9, "File System" on page 117
- ❑ Chapter 10, "Event Logs and the Syslog Client" on page 121
- ❑ Chapter 11, "Classifiers" on page 125
- ❑ Chapter 12, "Access Control Lists" on page 135
- ❑ Chapter 13, "Class of Service" on page 147
- ❑ Chapter 14, "Quality of Service" on page 155
- ❑ Chapter 15, "Denial of Service Defenses" on page 177
- ❑ Chapter 16, "Power Over Ethernet" on page 189



## Chapter 9

# File System

---

The chapter explains the switch's file system and contains the following sections:

- ❑ "Overview" on page 118
- ❑ "File Naming Conventions" on page 119
- ❑ "Using Wildcards to Specify Groups of Files" on page 120

## Overview

---

The AT-9400 Switch has a file system in flash memory for storing system files. You can view a list of the files as well as copy, rename, and delete files. For those AT-9400 Switches that support a compact flash memory card, you can perform the same functions on the files stored on a flash card, as well as copy files between the switch's file system and a flash card.

The file system supports the following file types:

- Configuration files
- Public keys
- CA and self-signed certificates
- Certificate enrollment requests
- Event logs

For an explanation of boot configuration files, refer to “Configuration Files” on page 48 and “Stack Configuration Files” on page 71.

Public encryption keys, public certificates, and certificate enrollment request files are related to the Secure Sockets Layer (SSL) certificates feature described in Chapter 35, “Encryption Keys” on page 411 and Chapter 36, “PKI Certificates and SSL” on page 421. Refer to those chapters for background information on those files.

---

### Note

The certificate file, certificate enrollment request file, and key file are supported only on the version of AT-S63 Management Software that features SSL and PKI security.

---

---

### Note

The file system may contain one or more ENC.UKF files. These are encryption key pairs. These files cannot be deleted, copied, or exported from the file system. For further information, refer to Chapter 35, “Encryption Keys” on page 411.

---

## File Naming Conventions

---

The flash memory file system is a flat file system—directories are not supported. However, directories are supported on compact flash cards. In both types of storage, files are uniquely identified by a file name in the following format:

`filename.ext`

where:

- ❑ *filename* is a descriptive name for the file, and may be one to sixteen characters in length. Valid characters are lowercase letters (a–z), uppercase letters (A–Z), digits (0–9), and the following characters: ~ ' @ # \$ % ^ & ( ) \_ - { }. Invalid characters are: ! \* + = " | \ [ ] ; : ? / , < > .
- ❑ *ext* is a file name extension of three characters in length, preceded by a period (.). The extension is used by the switch to determine the file type.

Table 39. File Extensions and File Types

Extension	File Type
.cfg	Configuration file
.cer	Certificate file
.csr	Certificate enrollment request
.key	Public encryption key
.log	Event log

The following is an example of a valid file name for a boot configuration file:

`standardconfig.cfg`

The following is an example of an invalid file name for a file stored in flash memory:

`sys/head_o.cfg`

The backslash character (/) is not a valid character for files stored in flash memory because subdirectories are not supported in the flash memory system.

The file system displays filenames and directories in DOS 28.3 format. Filenames and directories longer than 32 bytes are represented in DOS 8.3 format.

## Using Wildcards to Specify Groups of Files

---

You can use the asterisk character (\*) as a wildcard character in some fields to identify groups of files. In addition, a wildcard can be combined with other characters. The following are examples of valid wildcard expressions:

\*.cfg

\*.key

28\*.cfg



## Chapter 10

# Event Logs and the Syslog Client

---

This chapter describes how to monitor the activity of a switch by viewing the event messages in the event logs and sending the messages to a syslog server. Sections in the chapter include:

- ❑ “Supported Platforms” on page 122
- ❑ “Overview” on page 123
- ❑ “Event Messages” on page 123
- ❑ “Syslog Client” on page 124

## Supported Platforms

---

Refer to Table 40 and Table 41 for the AT-9400 Switches and the management interfaces that support the event logs and the syslog client.

Table 40. Support for the Event Logs and the Syslog Client

Switch	Supported
Layer 2+ Models	
AT-9408LC/SP	Yes
AT-9424T/GB	Yes
AT-9424T/SP	Yes
Basic Layer 3 Models	
AT-9424T	Yes
AT-9424T/POE	Yes
AT-9424Ts	Yes
AT-9424Ts/XP	Yes
AT-9448T/SP	Yes
AT-9448Ts/XP	Yes
AT-9400Ts Stack	Yes

Table 41. Management Interfaces for the Event Logs and the Syslog Client

Switch or Stack	Standard Command Line	AlliedWare Plus Command Line	Menus	Web Browser
Stand-alone Switch	Yes		Yes	Yes
AT-9400Ts Stack	Yes			Yes

## Overview

---

A managed switch is a complex piece of computer equipment that includes both hardware and software. Multiple software features operate simultaneously, interoperating with each other and processing large amounts of network traffic. It is often difficult to determine exactly what is happening when a switch appears not to be operating normally, or what happened when a problem occurred.

The operation of the switch can be monitored by viewing the event messages generated by the device. These events and the vital information about system activity that they provide can help identify and solve system problems.

## Event Messages

---

Event messages include the following information:

- The time and date of the event
- The severity of the event
- The management module that generated the event
- An event description

The switch has two event logs for storing the event messages. One log is located in temporary memory and has a storage capacity of up to 4,000 entries. The events in this log are purged whenever you reset or power cycle the switch. The second log is located in permanent memory and has a maximum storage capacity of 2,000 entries. Events in this log are retained when the switch is reset or power cycled. Both logs store the same events messages. You can view either log to display the events of the switch since the unit was last reset. But to view the events that preceded a system reset, you must view the permanent event log.

## Syslog Client

---

The management software features a syslog client to send event messages to a syslog server on your network. A syslog server can function as a central repository for events from many different network devices.

In order for the switch to send events to a syslog server, you must define a syslog output by specifying the IP address of the syslog server along with other information, such as the types of event messages the switch is to send to the server. You can create up to 19 syslog definitions on the switch.

---

### Note

The event logs, even when disabled, log all the AT-S63 initialization events that occur when the switch is reset or power cycled. Any switch events that occur after the AT-S63 initialization are entered into the logs only if you enable the event log feature. The default setting for the event log feature is enabled.

---

Observe the following guidelines when using this feature:

- ❑ You can define up to 19 log output definitions.
- ❑ The event logs on the switch must be activated in order for the switch to send events to a syslog server.
- ❑ There must be a routing interface on a local subnet from where the switch is communicating with a syslog server. The switch uses the IP address of a routing interface as its source address to communicate with a server. For background information on routing interfaces, refer to Chapter 29, “Internet Protocol Version 4 Packet Routing” on page 321.

---

### Note

Prior to version 2.0.0 of the AT-S63 Management Software, the switch could only communicate with a syslog server through its management VLAN. This restriction no longer applies. The switch can now communicate with a syslog server from any local subnet that has a routing interface.

---

## Chapter 11

# Classifiers

---

This chapter explains classifiers for access control lists and Quality of Service policies. The sections in this chapter include:

- ❑ “Supported Platforms” on page 126
- ❑ “Overview” on page 127
- ❑ “Classifier Criteria” on page 129
- ❑ “Guidelines” on page 134

## Supported Platforms

---

Refer to Table 42 and Table 43 for the AT-9400 Switches and the management interfaces that support classifiers.

Table 42. Support for Classifiers

Switch	Supported
Layer 2+ Models	
AT-9408LC/SP	Yes
AT-9424T/GB	Yes
AT-9424T/SP	Yes
Basic Layer 3 Models	
AT-9424T	Yes
AT-9424T/POE	Yes
AT-9424Ts	Yes
AT-9424Ts/XP	Yes
AT-9448T/SP	Yes
AT-9448Ts/XP	Yes
AT-9400Ts Stack	Yes

Table 43. Management Interfaces for Classifiers

Switch or Stack	Standard Command Line	AlliedWare Plus Command Line	Menus	Web Browser
Stand-alone Switch	Yes	Yes	Yes	Yes
AT-9400Ts Stack	Yes	Yes		

## Overview

---

A classifier defines a *traffic flow*. A traffic flow consists of packets that share one or more characteristics. A traffic flow can range from being very broad to very specific. An example of the former might be all IP traffic while an example of the latter could be packets with specific source and destination MAC addresses.

A classifier contains a set of criteria for defining a traffic flow. Examples of the variables include source and destination MAC addresses, source and destination IP addresses, IP protocols, source and destination TCP and UDP ports numbers, and so on. You can also specify more than one criteria within a classifier to make the definition of the traffic flow more specific. Some of the variables you can mix-and-match, but there are restrictions, as explained later in this section in the descriptions of the individual variables.

By itself, a classifier does not perform any action or produce any result because it lacks instructions on what a port should do when it receives a packet that belongs to the defined traffic flow. Rather, the action is established outside the classifier. As a result, you will never use a classifier by itself.

There are two AT-S63 features that use classifiers. They are:

- ❑ Access control lists (ACL)
- ❑ Quality of Service (QoS) policies

As explained in Chapter 12, “Access Control Lists” on page 135, an ACL filters ingress packets on a port by controlling which packets a port will accept and reject. You can use this feature to improve the security of your network or enhance network performance by creating network paths or links dedicated to carrying specific types of traffic.

When you create an ACL you must specify the traffic flow you want the ACL to control. You do that by creating one or more classifiers and adding the classifiers to the ACL. The action that the port takes when an ingress packet matches the traffic flow specified by a classifier is contained in the ACL itself. The action will be to either accept packets of the traffic flow or discard them.

The other feature that uses classifiers is Quality of Service (QoS) policies. You can use this feature to regulate the various traffic flows that pass through the switch. For instance, you might raise or lower their user priority values or increase or decrease their allotted bandwidths.

As with an ACL, you specify the traffic flow of interest by creating one or more classifiers and applying them to a QoS policy. The action to be taken by a port when it receives a packet that corresponds to the prescribed flow

is dictated by the QoS policy, as explained in Chapter 14, “Quality of Service” on page 155.

In summary, a classifier is a list of variables that define a traffic flow. You apply a classifier to an ACL or a QoS policy to define the traffic flow you want the ACL or QoS policy to affect or control.



## Classifier Criteria

---

The components of a classifier are defined in the following subsections.

### **Destination MAC Address (Layer 2)**

### **Source MAC Address (Layer 2)**

You can identify a traffic flow by specifying a source and/or destination MAC address. For instance, you might create a classifier for a traffic flow destined to a particular destination node, or from a specific source node to a specific destination node, all identified by their MAC addresses.

The management software does not support a classifier based on a range of MAC addresses. Different MAC addresses must be considered separate traffic flows, with their own classifiers.

### **Ethernet 802.2 and Ethernet II Frame Types (Layer 2)**

You can create a classifier that filters packets based on Ethernet frame type and whether a packet is tagged or untagged within a frame type. (A tagged Ethernet frame contains within it a field that specifies the ID number of the VLAN to which the frame belongs. Untagged packets lack this field.) Options are:

- Ethernet II tagged packets
- Ethernet II untagged packets
- Ethernet 802.2 tagged packets
- Ethernet 802.2 untagged packets

### **802.1p Priority Level (Layer 2)**

A tagged Ethernet frame, as explained in “Tagged VLAN Overview” on page 279, contains within it a field that specifies its VLAN membership. Such frames also contain a user priority level used by the switch to determine the Quality of Service to apply to the frame and which egress queue on the egress port a packet should be stored in. The three bit binary number represents eight priority levels, 0 to 7, with 0 the lowest priority and 7 the highest. Figure 5 illustrates the location of the user priority field within an Ethernet frame.

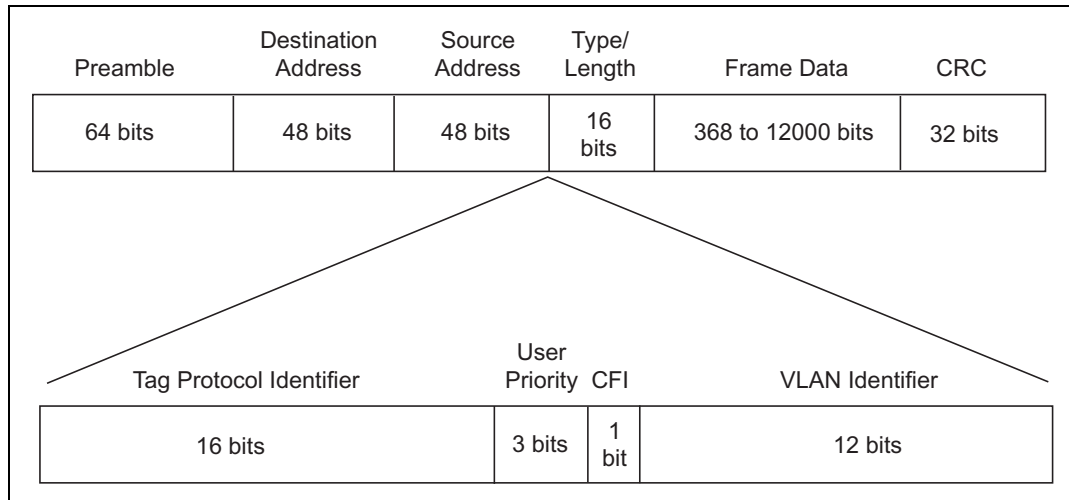

Figure 5. User Priority and VLAN Fields within an Ethernet Frame

You can identify a traffic flow of tagged packets using the user priority value. A classifier for such a traffic flow would instruct a port to watch for tagged packets containing the specified user priority level.

The priority level criteria can contain only one value, and the value must be from 0 (zero) to 7. Multiple classifiers are required if a port is to watch for several different traffic flows of different priority levels.

### VLAN ID (Layer 2)

A tagged Ethernet frame also contains within it a field of 12 bits that specifies the ID number of the VLAN to which the frame belongs. The field, illustrated in Figure 5, can be used to identify a traffic flow.

A classifier can contain only one VLAN ID. To create a port ACL or QoS policy that applies to several different VLAN IDs, multiple classifiers are required.

### Protocol (Layer 2)

Traffic flows can be identified by the protocol specified in the Ethertype field of the MAC header in an Ethernet II frame. Possible values are:

- IP
- ARP
- RARP
- Protocol Number

Observe the following guidelines when using this variable:

- ❑ When selecting a Layer 3 or Layer 4 variable, this variable must be left blank or set to IP.
- ❑ If you choose to specify a protocol by its number, you can enter the value in decimal or hexadecimal format. If you choose the latter, precede the number with the prefix "0x".
- ❑ The range for the protocol number is 1536 (0x600) to 65535 (0xFFFF).

### IP ToS (Type of Service) (Layer 3)

Type of Service (ToS) is a standard field in IP packets. It is used by applications to indicate the priority and Quality of Service for a frame. The range of the value is 0 to 7. The location of the field is shown in Figure 6.

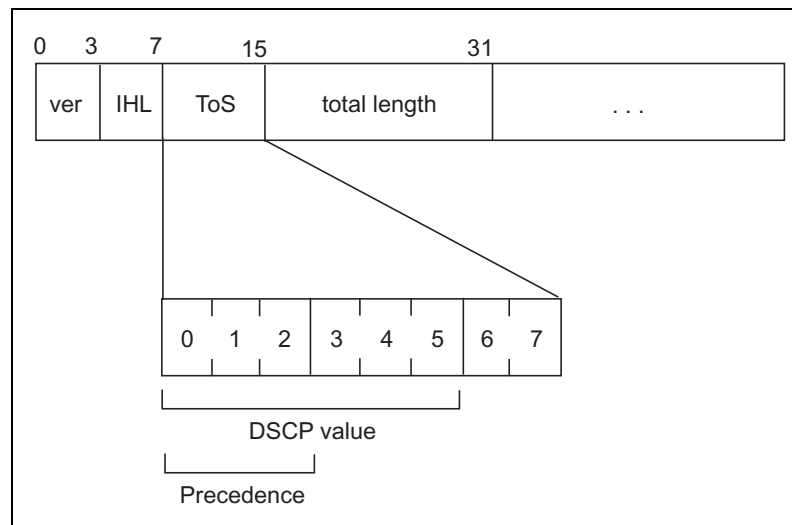

Figure 6. ToS field in an IP Header

Observe these guidelines when using this criterion:

- ❑ The Protocol variable must be left blank or set to IP.
- ❑ You cannot specify both an IP ToS value and an IP DSCP value in the same classifier.

### IP DSCP (DiffServ Code Point) (ToS) (Layer 3)

The Differentiated Services Code Point (DSCP) tag indicates the class of service to which packets belong. The DSCP value is written into the TOS field of the IP header, as shown in Figure 6 on page 131. Routers within the network use this DSCP value to classify packets, and assign QoS appropriately. When a packet leaves the DiffServ domain, the DSCP value can be replaced with a value appropriate for the next DiffServ domain. The range of the value is 0 to 63.

Observe these guidelines when using this criterion:

- The Protocol variable must be left blank or set to IP.
- You cannot specify both an IP ToS value and an IP DSCP value in the same classifier.

### **IP Protocol (Layer 3)**

You can define a traffic flow by the following Layer 3 protocols:

- TCP
- UDP
- ICMP
- IGMP
- IP protocol number

If you choose to specify the protocol by its number, you can enter the value in decimal or hexadecimal format. In the latter, include the prefix "0x". The range for the protocol number is 0 (0x0) to 255 (0xFF).

### **Source IP Addresses (Layer 3)**

#### **Source IP Mask (Layer 3)**

You can define a traffic flow by the source IP address contained in IP packets. The address can be of a subnet or a specific end node.

You do not need to enter a source IP mask if you are filtering on the IP address of a specific end node. A mask is required, however, when you filter on a subnet. A binary "1" indicates the switch should filter on the corresponding bit of the IP address, while a "0" indicates that it should not. For example, the subnet address 149.11.11.0 would have the mask "255.255.255.0."

Observe this guideline when using these criteria:

- The Protocol variable must be left blank or set to IP.

### **Destination IP Addresses (Layer 3)**

#### **Destination IP Mask (Layer 3)**

You can also define a traffic flow based on the destination IP address of a subnet or a specific end node.

You do not need to enter a destination IP mask for an IP address of a specific end node. A mask is required, however, when filtering on a subnet. A binary "1" indicates the switch should filter on the corresponding bit of the IP address while a "0" indicates that it should not. For example, the subnet address 149.11.11.0 would have the mask "255.255.255.0."

Observe this guideline when using these criteria:

- The Protocol variable must be left blank or set to IP.

#### **TCP Source Ports (Layer 4)**

#### **TCP Destination Ports (Layer 4)**

A traffic flow can be identified by a source and/or destination TCP port number contained within the header of an IP frame. Observe the following guidelines when using these criteria:

- The Protocol variable must be left blank or set to IP.
- The IP Protocol variable must be left blank or set to TCP.
- A classifier cannot contain criteria for both TCP and UDP ports. You may specify one in a classifier, but not both.

#### **UDP Source Ports (Layer 4)**

#### **UDP Destination Ports (Layer 4)**

A traffic flow can be identified by a source and/or destination UDP port number contained within the header of an IP frame. Observe the following guidelines when using these criteria:

- The Protocol variable must be left blank or set to IP.
- The IP Protocol variable must be left blank or set to UDP.
- A classifier cannot contain criteria for both TCP and UDP ports. You may specify only one in a classifier.

#### **TCP Flags**

A traffic flow can be based on the following TCP flags:

- URG - Urgent
- ACK - Acknowledgement
- RST - Reset
- PSH - Push
- SYN - Synchronization
- FIN - Finish

Observe the following guidelines when using this criterion:

- The Protocol variable must be left blank or set to IP.
- The IP Protocol variable must be left blank or set to TCP.
- A classifier cannot contain both a TCP flag and a UDP source and/or destination port.

## Guidelines

---

Follow these guidelines when creating a classifier:

- ❑ Each classifier represents a separate traffic flow.
- ❑ The variables within a classifier are linked by AND. The more variables you define within a classifier, the more specific it becomes in terms of the flow it defines. For instance, specifying both a source IP address and a TCP destination port within the same classifier defines a traffic flow that relates to IP packets containing both the designated source IP address and the TCP destination port. There are, however, some restrictions on combining variables in the same classifier. For the restrictions, refer to “Classifier Criteria” on page 129.
- ❑ The same classifier can belong to ACLs and QoS policies.
- ❑ You can apply the same classifier to more than one ACL or QoS policy.
- ❑ A classifier without any defined variables applies to all packets.
- ❑ You cannot create two classifiers that have the same settings. There can be only one classifier for any given type of traffic flow.
- ❑ A classifier can have a maximum of eight defined criteria, not including the classifier ID number and the description.
- ❑ The switch can store up to 256 classifiers. However, the maximum number of classifiers you can assign to active access control lists and QoS policies at any one time will be from 14 to 127. The number depends on several factors, such as the number of ports to which the classifiers are assigned and the types of criteria defined in the classifiers.
- ❑ You cannot modify a classifier if it belongs to an ACL or QoS policy that is assigned to a port. You must remove the port assignments from the ACL or policy and reassign them after modifying the classifier.
- ❑ You cannot delete a classifier if it belongs to an ACL or QoS policy. You must remove a classifier from its ACLs and QoS policies before you can delete it.

## Chapter 12

# Access Control Lists

---

This chapter describes access control lists (ACL) and how they can improve network security and performance. This chapter contains the following sections:

- ❑ “Supported Platforms” on page 136
- ❑ “Overview” on page 137
- ❑ “Parts of an ACL” on page 139
- ❑ “Guidelines” on page 140
- ❑ “Examples” on page 141

## Supported Platforms

---

Refer to Table 44 and Table 45 for the AT-9400 Switches and the management interfaces that support the access control lists.

Table 44. Support for the Access Control Lists

Switch	Supported
Layer 2+ Models	
AT-9408LC/SP	Yes
AT-9424T/GB	Yes
AT-9424T/SP	Yes
Basic Layer 3 Models	
AT-9424T	Yes
AT-9424T/POE	Yes
AT-9424Ts	Yes
AT-9424Ts/XP	Yes
AT-9448T/SP	Yes
AT-9448Ts/XP	Yes
AT-9400Ts Stack	Yes

Table 45. Management Interfaces for the Access Control Lists

Switch or Stack	Standard Command Line	AlliedWare Plus Command Line	Menus	Web Browser
Stand-alone Switch	Yes	Yes	Yes	Yes
AT-9400Ts Stack	Yes	Yes		



## Overview

---

An access control list is a filter that controls the ingress traffic on a port. It defines a category of traffic and the action of the port when it receives packets of the category. The action can be to accept the defined packets or discard them. You can use this feature to increase the security to your network by restricting access to certain areas or subnets, or to enhance network performance by forming network links dedicated to carrying specified types of traffic.

---

**Note**

This feature is not related to the management ACL feature, described in Chapter 39, “Management Access Control List” on page 455. They perform different functions and are configured in different ways.

---

The heart of an ACL is a classifier. A classifier, as explained “Overview” on page 127, defines packets that share a common trait. Packets that share a trait are referred to as a traffic flow. A traffic flow can be very broad, such as all IP packets, or very specific, such as packets from a specified end node destined for another specified node. You specify the traffic using different criteria, such as source and destination MAC addresses or protocol.

When you create an ACL, you must specify the classifier that defines the traffic flow to permit or deny on a port.

There are two kinds of ACLs based on the two actions that an ACL can perform. One is called a permit ACL. Packets that meet the criteria in a permit ACL are accepted by a port.

The second type of ACL is a deny ACL. This type of ACL denies entry to packets that meet the criteria of its classifiers, unless the packet also meets the criteria of a permit ACL on the same port, in which case the packet is accepted. This is because a permit ACL overrides a deny ACL.

Here is an overview of how the process works.

1. When an ingress packet arrives on a port, it is checked against the criteria in the classifiers of all the ACLs, both permit and deny, assigned to the port.
2. If the packet matches the criteria of a permit ACL, the port immediately accepts it, even if the packet also matches a deny ACL assigned to the same port, because a permit ACL always overrides a deny ACL.
3. If a packet meets the criteria of a deny ACL but not any permit ACLs on the port, then the packet is discarded.

4. Finally, if a packet does not meet the criteria of any ACLs on a port, it is accepted by the port.

## Parts of an ACL

---

An ACL must have the following information:

- ❑ Name - An ACL must have a name. The name of an ACL should indicate the type of traffic flow being filtered and, perhaps, also the action. An example might be “HTTPS flow - permit.” The more specific the name, the easier it will be for you to identify it.
- ❑ Action - The action of an ACL can be permit or deny. Ingress traffic that meets the criteria of an ACL with the permit action is accepted by a port. Ingress traffic that meets the criteria of an ACL with the deny action is discarded by a port, unless the traffic also meets the criteria of a permit ACL on the same port, in which case it is accepted.
- ❑ Classifiers - An ACL must have at least one classifier. An ACL can have more than one classifier to filter multiple traffic flows.
- ❑ Port Lists - Finally, you need to specify the ports for the ACL.

## Guidelines

---

Here are the rules to creating ACLs:

- ❑ A port can have multiple permit and deny ACLs.
- ❑ An ACL must have at least one classifier.
- ❑ An ACL can be assigned to more than one switch port.
- ❑ An ACL filters ingress traffic, but not egress traffic.
- ❑ The action of a ACL can be either permit or deny. A permit ACL overrides a deny ACL on the same port when the ACLs define the same traffic.
- ❑ The order in which the ACLs are added to a port is not important since the packets are compared against all of a port's ACLs.
- ❑ Since classifiers cannot be assigned more than once to a port, ACLs that have the same classifier cannot be assigned to the same port.
- ❑ An ACL and a Quality of Service policy cannot be assigned to the same port if they have a common classifier.
- ❑ The switch can store up to 64 ACLs.

## Examples

---

This section contains several examples of ACLs.

In this example, port 4 has been assigned one ACL, a deny ACL for the subnet 149.11.11.0. This ACL prevents the port from accepting any traffic originating from that subnet. Since this is the only ACL on the port, all other traffic is accepted. As explained earlier, a port automatically accepts all packets that do not meet the criteria of the classifiers assigned to its ACLs.

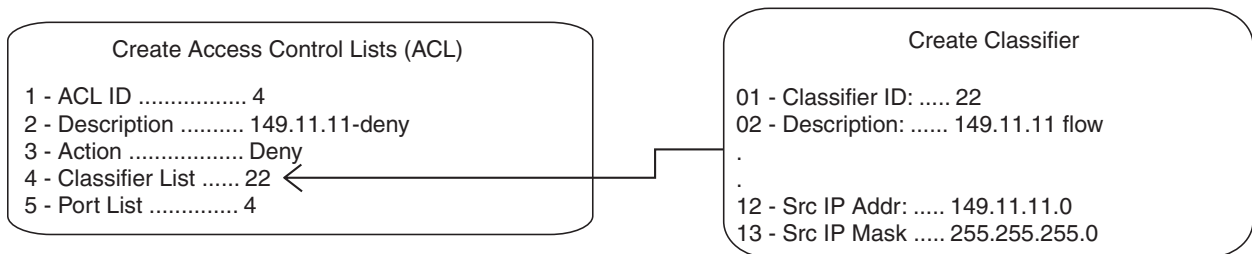

Figure 7. ACL Example 1

To deny traffic from several subnets on the same port, you can create multiple classifiers and apply them to the same ACL, as illustrated in the next example. Three subnets are denied access to port 4. The three classifiers defining the subnets are applied to the same ACL.

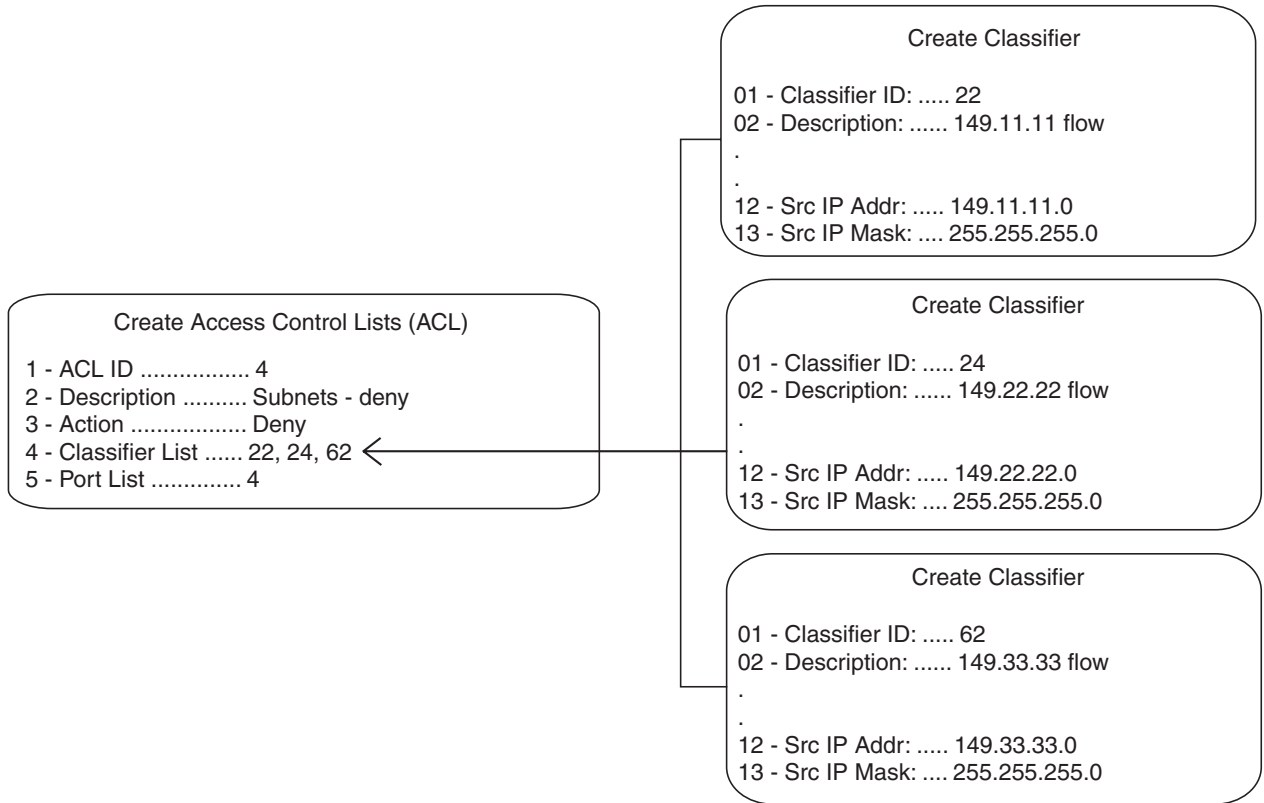

Figure 8. ACL Example 2

The same result can be achieved by assigning the classifiers to different ACLs and assigning the ACLs to the same port, as in this example, again for port 4.

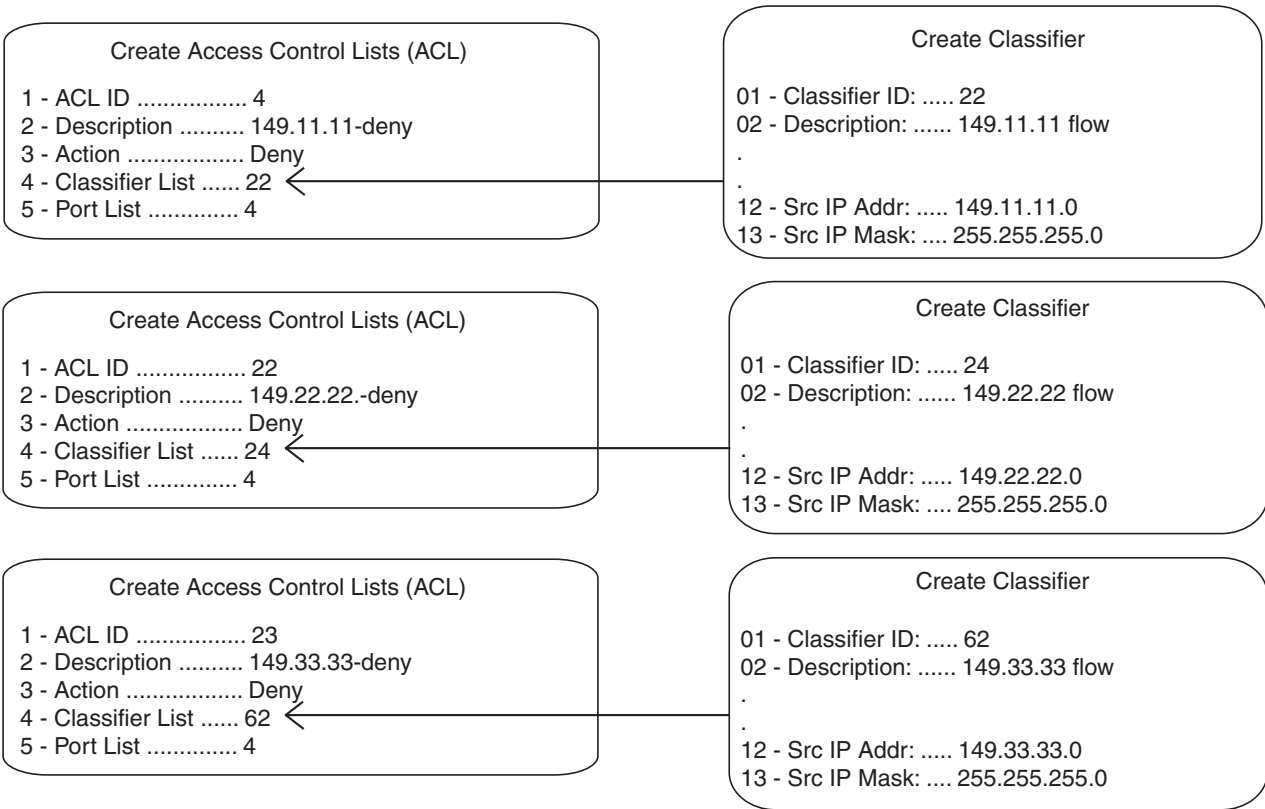

Figure 9. ACL Example 3

In this example, the traffic on ports 14 and 15 is restricted to packets from the source subnet 149.44.44.0. All other IP traffic is denied. Classifier ID 11, which specifies the traffic flow to be permitted by the ports, is assigned to an ACL with an action of permit. Classifier ID 17 specifies all IP traffic and is assigned to an ACL whose action is deny. Since a permit ACL overrides a deny ACL, the port will accept the traffic from the 149.44.44.0 subnet and discard all other IP traffic.

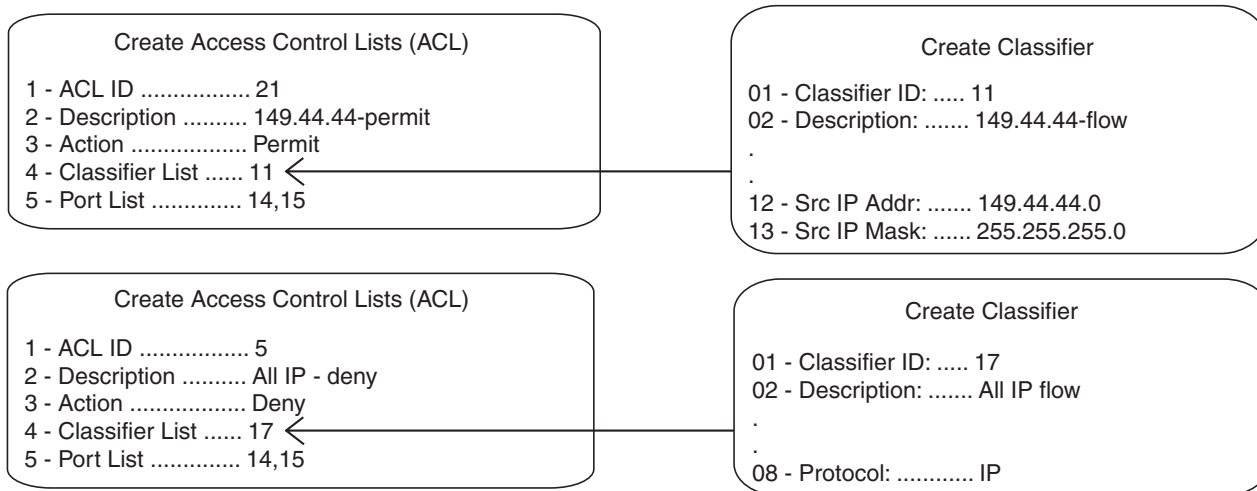

Figure 10. ACL Example 4

This example limits the traffic on port 22 to HTTPS web traffic intended for the end node with the IP address 149.55.55.55, and rejects all other IP traffic. (The Dst IP Mask field in classifier 6 is left empty because a mask is not required for a source or destination IP address for a specific end node. If you wanted to include it, it would be 255.255.255.255.)

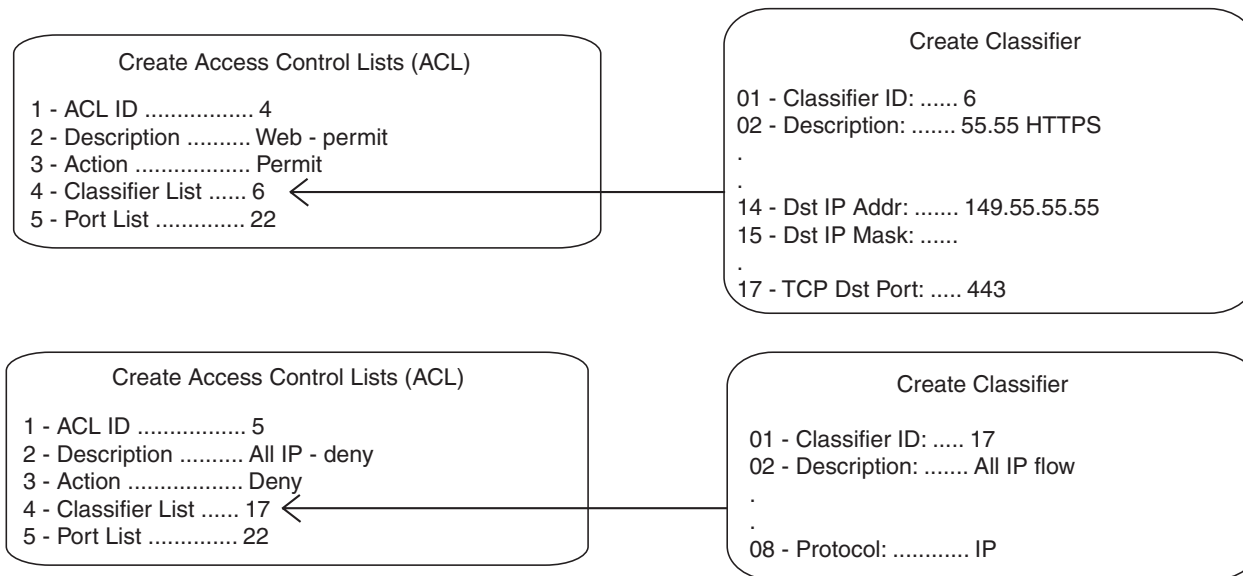

Figure 11. ACL Example 5



The next example limits the ingress traffic on port 17 to IP packets from the subnet 149.22.11.0 and a Type of Service setting of 6, destined to the end node with the IP address 149.22.22.22. All other IP traffic and ARP packets are prohibited.

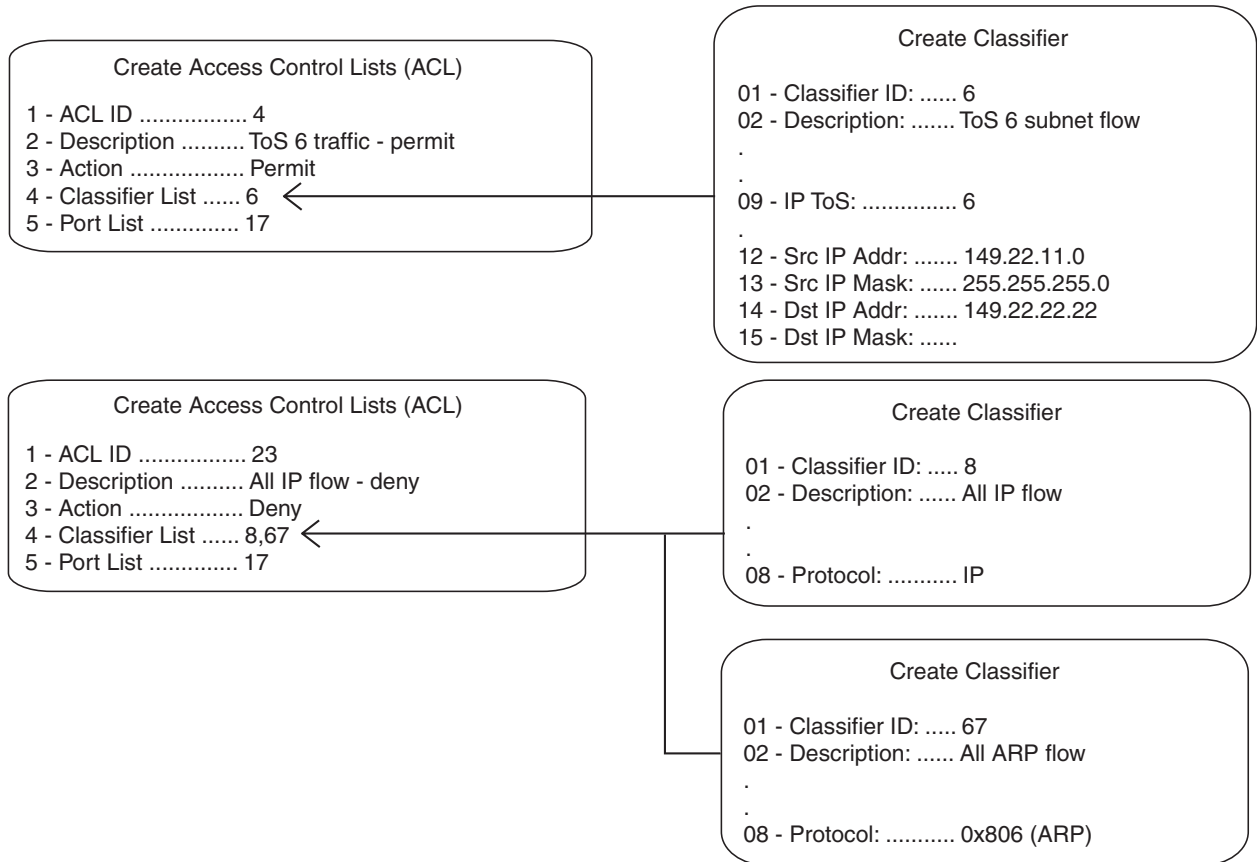

Figure 12. ACL Example 6



## Chapter 13

# Class of Service

---

This chapter describes the Class of Service (CoS) feature. Sections in the chapter include:

- ❑ “Supported Platforms” on page 148
- ❑ “Overview” on page 149
- ❑ “Scheduling” on page 152

## Supported Platforms

---

Refer to Table 46 and Table 47 for the AT-9400 Switches and the management interfaces that support the Class of Service feature.

Table 46. Support for the Class of Service Feature

Switch	Supported
Layer 2+ Models	
AT-9408LC/SP	Yes
AT-9424T/GB	Yes
AT-9424T/SP	Yes
Basic Layer 3 Models	
AT-9424T	Yes
AT-9424T/POE	Yes
AT-9424Ts	Yes
AT-9424Ts/XP	Yes
AT-9448T/SP	Yes
AT-9448Ts/XP	Yes
AT-9400Ts Stack	Yes

Table 47. Management Interfaces for the Class of Service Feature

Switch or Stack	Standard Command Line	AlliedWare Plus Command Line	Menus	Web Browser
Stand-alone Switch	Yes		Yes	Yes
AT-9400Ts Stack	Yes			

## Overview

---

When a port on an Ethernet switch becomes oversubscribed—its egress queues contain more packets than the port can handle in a timely manner—the port may be forced to delay the transmission of some packets, resulting in the delay of packets reaching their destinations. A port may be forced to delay transmission of packets while it handles other traffic. Some packets destined to be forwarded to an oversubscribed port from other switch ports may be discarded.

Although minor delays are often of no consequence to a network or its performance, there are applications, referred to as delay or time sensitive applications, that can be impacted by packet delays. Voice transmission and video conferencing are two examples. A delay in the transmission of packets carrying their data could impact the quality of the audio or video.

This is where CoS can be of value. What it does is it permits a switch to give higher priority to some packets over other packets.

There are two principal types of traffic found on the ports of a Gigabit Ethernet switch, one being untagged packets and the other tagged packets. As explained in “Tagged VLAN Overview” on page 279, one of the principal differences between them is that tagged packets contain VLAN information.

CoS applies mainly to tagged packets because, in addition to carrying VLAN information, these packets can also contain a priority level specifying how important (delay sensitive) a packet is in comparison to other packets. It is this number that the switch refers to when determining a packet's priority level.

CoS, as defined in the IEEE 802.1p standard, has eight levels of priority. The priorities are 0 to 7, with 0 the lowest priority and 7 the highest.

Each switch port has eight egress queues, labeled Q0, Q1, Q2, Q3, Q4, Q5, Q6, Q7. Q0 is the lowest priority queue and Q7 is the highest. A packet in a high priority egress queue is typically transmitted out a port sooner than a packet in a low priority queue.

When a tagged packet arrives on a port, the switch examines its priority value to determine which egress priority queue the packet should be directed to on the egress port. Table 48 lists the default mappings between the eight CoS priority levels and the eight egress queues of a switch port.

Table 48. Default Mappings of IEEE 802.1p Priority Levels to Priority Queues

IEEE 802.1p Priority Level	Port Priority Queue
0	Q1
1	Q0 (lowest)
2	Q2
3	Q3
4	Q4
5	Q5
6	Q6
7	Q7 (highest)

For example, when a tagged packet with a priority level of 3 enters a port on the switch, the packet is stored in Q3 queue on the egress port.

Note that priority 0 is mapped to CoS queue 1 instead of CoS queue 0 because tagged traffic that has never been prioritized has a VLAN tag User Priority of 0. If priority 0 was mapped to CoS queue 0, this default traffic goes to the lowest queue, which is probably undesirable. This mapping also makes it possible to give some traffic a lower priority than the default traffic.

You can change these mappings. For example, you might decide that packets with a priority of 5 should be handled by egress queue Q3 and packets with a priority of 2 should be handled in Q1. The result is shown in Table 49.

Table 49. Customized Mappings of IEEE 802.1p Priority Levels to Priority Queues

IEEE 802.1p Priority Level	Port Priority Queue
0	Q1
1	Q0 (lowest)
2	Q1
3	Q3
4	Q4
5	Q3

Table 49. Customized Mappings of IEEE 802.1p Priority Levels to Priority Queues (Continued)

IEEE 802.1p Priority Level	Port Priority Queue
6	Q6
7	Q7 (highest)

Note that because all ports must use the same priority-to-egress queue mappings, these mappings are applied at the switch level. They cannot be set on a per-port basis.

You can configure a port to completely ignore the priority levels in its tagged packets and instead use a temporary priority level assigned to the port. For instance, perhaps you decide that all tagged packets received on port 4 should be assigned a priority level of 5, regardless of the priority level in the packets themselves.

CoS relates primarily to tagged packets rather than untagged packets because untagged packets do not contain a priority level. By default, all untagged packets are assigned a priority of 0 and are placed in a port's Q1 egress queue. But you can override this and instruct a port's untagged frames to be stored in a different priority queue.

One last thing to note is that CoS does not change the priority level in a tagged packet. The packet leaves the switch with the same priority it had when it entered. This is true even if you change the default priority-to-egress queue mappings.

## Scheduling

---

A switch port needs a mechanism that specifies the order of transmittal of the packets from its eight egress queues. For example, should a port that has packets in all its queues transmit all the packets from Q7, the highest priority queue, before moving on to the other queues, or should it transmit a few packets from each queue and, if so, how many?

This control mechanism is called *scheduling*. The AT-S63 Management Software has two types of scheduling:

- Strict priority
- Weighted round robin priority

---

### Note

Scheduling is set at the switch level. You cannot set this on a per-port basis.

---

### Strict Priority Scheduling

A port set to this scheduling method transmits all the packets out of the higher priority queues before transmitting the packets in the lower priority queues. For instance, as long as there are packets in Q7 a port does not handle any of the packets in Q6.

The value to this type of scheduling is that high priority packets are always handled before low priority packets.

The problem with this method is that some low priority packets might never be transmitted out the port because a port might never get to the low priority queues. A port handling a large volume of high priority traffic may be so busy transmitting that traffic that it never has an opportunity to get to any of the packets stored in its low priority queues.

### Weighted Round Robin Priority Scheduling

The weighted round robin scheduling method functions as its name implies. The port transmits a set number of packets from each queue, in a round robin fashion, so that each has a chance to transmit traffic. This method guarantees that every queue receives some attention from the port for transmitting packets.

To use this scheduling method, you need to specify the maximum number of packets a port should transmit from a queue before moving to the next queue. This is referred to as specifying the “weight” of a queue. In most cases, you will want to give greater weight to the higher priority queues over the lower priority queues.



Table 50 shows an example.

Table 50. Example of Weighted Round Robin Priority

Port Egress Queue	Maximum Number of Packets
Q0 (lowest)	1
Q1	1
Q2	5
Q3	5
Q4	5
Q5	5
Q6	10
Q7	15

In this example, the port transmits a maximum number of 15 packets from Q7 before moving to Q6, from where it transmits up to 10 packets, and so forth.

For Q0 to Q6, the range of the maximum number of transmitted packets is 1 to 15. The range for Q7, the highest priority queue, is 0 to 15. Setting Q7 to 0 means its packets always take priority over the packets in the other queues and that no packets are transmitted from the lower priority queues so long as there are packets in Q7. This allows you to combine the two priority scheduling methods on the same port.

An example of Q7 with a weight of 0 is shown in Table 51. At these settings, a port transmits all of the packets from Q7 until the queue is empty, and then transmits a maximum of 15 packets from Q6, 8 packets from Q5, and so forth.

Table 51. Example of a Weight of Zero for Priority Queue 7

Port Egress Queue	Maximum Number of Packets
Q0 (lowest)	1
Q1	1
Q2	8
Q3	8
Q4	8
Q5	8

Table 51. Example of a Weight of Zero for Priority Queue 7 (Continued)

<b>Port Egress Queue</b>	<b>Maximum Number of Packets</b>
Q6	15
Q7	0

## Chapter 14

# Quality of Service

---

This chapter describes Quality of Service (QoS). Sections in the chapter include:

- ❑ “Supported Platforms” on page 156
- ❑ “Overview” on page 157
- ❑ “Classifiers” on page 159
- ❑ “Flow Groups” on page 160
- ❑ “Traffic Classes” on page 161
- ❑ “Policies” on page 162
- ❑ “QoS Policy Guidelines” on page 163
- ❑ “Packet Processing” on page 164
- ❑ “Bandwidth Allocation” on page 164
- ❑ “Packet Prioritization” on page 164
- ❑ “Replacing Priorities” on page 166
- ❑ “VLAN Tag User Priorities” on page 166
- ❑ “DSCP Values” on page 166
- ❑ “DiffServ Domains” on page 167
- ❑ “Examples” on page 169

## Supported Platforms

---

Refer to Table 52 and Table 53 for the AT-9400 Switches and the management interfaces that support Quality of Service.

Table 52. Support for Quality of Service

Switch	Supported
Layer 2+ Models	
AT-9408LC/SP	Yes
AT-9424T/GB	Yes
AT-9424T/SP	Yes
Basic Layer 3 Models	
AT-9424T	Yes
AT-9424T/POE	Yes
AT-9424Ts	Yes
AT-9424Ts/XP	Yes
AT-9448T/SP	Yes
AT-9448Ts/XP	Yes
AT-9400Ts Stack	Yes

Table 53. Management Interfaces for Quality of Service

Switch or Stack	Standard Command Line	AlliedWare Plus Command Line	Menus	Web Browser
Stand-alone Switch	Yes	Yes	Yes	Yes
AT-9400Ts Stack	Yes	Yes		

## Overview

---

Quality of Service allows you to prioritize traffic and/or limit the bandwidth available to it. The concept of QoS is a departure from the original networking protocols, which treated all traffic on the Internet or within a LAN in the same manner. Without QoS, every traffic type is equally likely to be dropped if a link becomes oversubscribed. This approach is now inadequate in many networks, because traffic levels have increased and networks transport time-critical applications such as streams of video and data. QoS also enables service providers to easily supply different customers with different amounts of bandwidth.

Configuring Quality of Service involves two separate stages:

- ❑ Classifying traffic into flows, according to a wide range of criteria.

Classification is performed by the switch's packet classifiers, described in Chapter 11, "Classifiers" on page 125.

- ❑ Acting on these traffic flows.

Quality of Service is a broadly used term that encompasses as a minimum both Layer 2 and Layer 3 in the OSI model. QoS is typically demonstrated by how the switch accomplishes the following:

- ❑ Assigns priority to incoming frames, if they do not carry priority information
- ❑ Maps prioritized frames to traffic classes, or maps frames to traffic classes based upon other criteria
- ❑ Maps traffic classes to egress queues, or maps prioritized frames to egress queues
- ❑ Provides maximum bandwidth limiting for traffic classes, egress queues and/or ports
- ❑ Schedules frames in egress queues for transmission (for example, empty queues in strict priority or samples each queue)
- ❑ Relabels the priority of frames
- ❑ Determines which frames to drop if the network becomes congested
- ❑ Reserves memory for switching/routing or QoS operation (e.g. reserving buffers for egress queues, or buffers to store packets with particular characteristics)

---

### Note

QoS is only performed on packets that are switched at wire speed. This includes IP, IP multicast, IPX, and Layer 2 traffic within VLANs.

---

The QoS functionality described in this chapter sorts packets into various flows, according to the QoS policy that applies to the port the traffic is received on. The switch then allocates resources to direct this traffic according to bandwidth or priority settings in the policy. A policy contains traffic classes, flow groups, and classifiers. Therefore, to configure QoS, you:

- ❑ Create *classifiers* to sort packets into traffic flows.
- ❑ Create *flow groups* and add classifiers to them. Flow groups are groups of classifiers which group together similar traffic flows. You can apply QoS prioritization to flow groups.
- ❑ Create *traffic classes* and add flow groups to them. Traffic classes are groups of flow groups and are central to QoS. You can apply bandwidth limits and QoS prioritization to traffic classes.
- ❑ Create *policies* and add traffic classes to them. Policies are groups of traffic classes. A policy defines a complete QoS solution for a port or group of ports.
- ❑ Associate policies with ports.

---

**Note**

The steps listed above are in a conceptually logical order, but the switch cannot check a policy for errors until the policy is attached to a port. To simplify error diagnosis, define your QoS configuration on paper first, and then enter it into the management software starting with classifiers.

---

Policies, traffic classes, and flow groups are created as individual entities. When a traffic class is added to a policy, a logical link is created between the two entities. Destroying the policy unlinks the traffic class, leaving the traffic class in an unassigned state. Destroying a policy does not destroy any of the underlying entities. Similarly, destroying a traffic class unlinks flow groups, and destroying flow groups unlinks classifiers.

## Classifiers

---

Classifiers identify a particular traffic flow, and range from general to specific. (See Chapter 11, “Classifiers” on page 125 for more information.) Note that a single classifier should not be used in different flows that will end up, through traffic classes, assigned to the same policy. A classifier should only be used once per policy. Traffic is matched in the order of classifiers. For example, if a flow group has classifiers 1, 3, 2 and 5, that is the order in which the packets are matched.

## Flow Groups

---

Flow groups group similar traffic flows together, and allow more specific QoS controls to be used, in preference to those specified by the traffic class. Flow groups consist of a small set of QoS parameters and a group of classifiers. After a flow group has been added to a traffic class it cannot be added to another traffic class. A traffic class may have many flow groups. Traffic is matched in the order of the flow groups. For example, if a traffic class has flow groups 1, 3, 2 and 5, this is the order in which the packets are matched.

QoS controls at the flow group level provide a QoS hierarchy. Non-default flow group settings are always used, but if no setting is specified for a flow group, the flow group uses the settings for the traffic class to which it belongs. For example, you can use a traffic class to limit the bandwidth available to web and FTP traffic combined. Within that traffic class, you can create two different flow groups with different priorities, to give web traffic a higher priority than FTP. Web traffic would then be given preferential access to bandwidth, but would be limited to the bandwidth limit of the traffic class.



## Traffic Classes

---

Traffic classes are the central component of the QoS solution. They provide most of the QoS controls that allow a QoS solution to be deployed. A traffic class can be assigned to only one policy. Traffic classes consist of a set of QoS parameters and a group of QoS *flow groups*. Traffic can be prioritized, marked (IP TOS or DSCP field set), and bandwidth limited. Traffic is matched in the order of traffic class. For example, if a policy has traffic classes 1, 3, 2 and 5, this is the order in which the packets are matched.

## Policies

---

QoS policies consist of a collection of user defined traffic classes. A policy can be assigned to more than one port, but a port may only have one policy.

Note that the switch can only perform error checking of parameters and parameter values for the policy and its traffic classes and flow groups when the policy is set on a port.

QoS controls are applied to ingress traffic on ports. Therefore, to control a particular type of traffic, an appropriate QoS policy must be attached to each port that type of traffic ingresses.

Although a policy can be applied to an egress port, the classifiers and the QoS controls are actually applied by the switch on the ingress ports of the traffic. This means the parameters used to classify the traffic and the actions specified by the policy are checked and applied on the ingress traffic of every port, before the traffic reaches an egress queue. As a consequence, a policy is never applied to the whole aggregated traffic of a designated egress port, but rather to the individual ingress flows destined to the port.

The effects of this behavior become evident when using the maximum bandwidth feature of QoS. Here is an example. Suppose you have a policy that assigns 5 Mbps of maximum bandwidth to an egress port. Now assume there are 10 ports on the switch where ingress traffic matches the criteria specified in the classifier assigned to the policy of the egress port. Since the policy considers each ingress flow separately, the result would be a maximum bandwidth of 50 Mbps (10 x 5 Mbps) on the egress port, because there are 10 flows, one from each ingress port, directed to the egress port.

An additional factor to consider when specifying an egress port in a policy is that if the destination MAC address of the traffic flow has not been learned by the egress port or, alternatively, added as a static address to the port, the policy remains inactive. This is because the ingress ports consider the traffic as unknown traffic and flood the traffic to all the ports. This applies equally to unknown unicast and unknown multicast traffic, as well as broadcast traffic.

## QoS Policy Guidelines

---

Following is a list of QoS policy guidelines:

- ❑ A classifier may be assigned to many flow groups. However, assigning a classifier more than once within the same policy may lead to undesirable results. A classifier may be used successfully in many different policies.
- ❑ A flow group must be assigned at least one classifier but may have many classifiers.
- ❑ A flow group may be assigned to only one traffic class.
- ❑ A traffic class may have many flow groups.
- ❑ A traffic class may only be assigned to one policy.
- ❑ A policy may have many traffic classes.
- ❑ A policy may be assigned to many ports.
- ❑ A port may only have one policy.
- ❑ You can create a policy without assigning it to a port, but the policy will be inactive.
- ❑ A policy must have at least one action defined in the flow group, traffic class, or the policy itself. A policy without an action is invalid.
- ❑ A Quality of Service policy and an access control list can coexist on the same port only if they have different classifiers.
- ❑ The switch can store up to 64 flow groups.
- ❑ The switch can store up to 64 traffic classes.
- ❑ The switch can store up to 64 policies.

## Packet Processing

---

You can use the switch's QoS tools to perform any combination of the following functions on a packet flow:

- ❑ Limiting bandwidth
- ❑ Prioritizing packets to determine the level of precedence the switch will give to the packet for processing
- ❑ Replacing the VLAN tag User Priority to enable the next switch in the network to process the packet correctly
- ❑ Replacing the TOS precedence or DSCP value to enable the next switch in the network to process the packet correctly.

## Bandwidth Allocation

---

Bandwidth limiting is configured at the level of traffic classes, and encompasses the flow groups contained in the traffic class. Traffic classes can be assigned maximum bandwidths, specified in kbps, Mbps, or Gbps.

## Packet Prioritization

---

The switch has eight Class of Service (CoS) egress queues, numbered from 0 to 7. Queue 7 has the highest priority. When the switch becomes congested, it gives high priority queues precedence over lower-priority queues. When the switch has information about a packet's priority, it sends the packet to the appropriate queue. You can specify the queue where the switch sends traffic, how much precedence each queue has, and whether priority remapping is written into the packet's header for the next hop to use.

Prioritizing packets cannot improve your network's performance when bandwidth is over-subscribed to the point that egress queues are always full. If one type of traffic is causing the congestion, you can limit its bandwidth. Other solutions are to increase bandwidth or decrease traffic.

You can set a packet's priority by configuring a priority in the flow group or traffic class to which the packet belongs. The packet is put in the appropriate CoS queue for that priority. If the flow group and traffic class do not include a priority, the switch can determine the priority from the VLAN tag User Priority field of incoming tagged packets. The packet is put in the appropriate CoS queue for its VLAN tag User Priority field. If neither the traffic class / flow group priority nor the VLAN tag User Priority is set, the packet is sent to the default queue, queue 1.

Both the VLAN tag User Priority and the traffic class / flow group priority setting allow eight different priority values (0-7). These eight priorities are mapped to the switch's eight CoS queues. The switch's default mapping is shown in Table 48 on page 150. Note that priority 0 is mapped to CoS queue 1 instead of CoS queue 0 because tagged traffic that has never been prioritized has a VLAN tag User Priority of 0. If priority 0 was mapped to CoS queue 0, this default traffic goes to the lowest queue, which is probably undesirable. This mapping also makes it possible to give some traffic a lower priority than the default traffic.

## Replacing Priorities

---

The traffic class or flow group priority (if set) determines the egress queue a packet is sent to when it egresses the switch, but by default has no effect on how the rest of the network processes the packet. To permanently change the packet's priority, you need to replace one of two priority fields in the packet header:

- ❑ The User Priority field of the VLAN tag header. Replacing this field relabels VLAN-tagged traffic, so that downstream switches can process it appropriately.
- ❑ The DSCP value of the IP header's TOS byte (Figure 6 on page 131). Replacing this field may be required as part of the configuration of a DiffServ domain. See "DiffServ Domains" on page 167 for information on using the QoS policy model and the DSCP value to configure a DiffServ domain.

## VLAN Tag User Priorities

---

Within a flow group or traffic class, the VLAN tag User Priority value of incoming packets can be replaced with the priority specified in the flow group or traffic class. Replacement occurs before the packet is queued, so this priority also sets the queue priority.

## DSCP Values

---

There are three methods for replacing the DSCP byte of an incoming packet. You can use these methods together or separately. They are described in the order in which the switch performs them.

- ❑ The DSCP value can be overwritten at ingress, for all traffic in a policy.
- ❑ The DSCP value in the packet can be replaced at the traffic class or flow group level.
- ❑ You can use these two replacements together at the edge of a DiffServ domain, to initialize incoming traffic.
- ❑ The DSCP value in a flow of packets can be replaced if the bandwidth allocated to that traffic class is exceeded. This option allows the next switch in the network to identify traffic that exceeded the bandwidth allocation.

## DiffServ Domains

Differentiated Services (DiffServ) is a method of dividing IP traffic into classes of service, without requiring that every router in a network remember detailed information about traffic flows. DiffServ operates within a *DiffServ domain*, a network or subnet that is managed as a single QoS unit. Packets are classified according to user-specified criteria at the edge of the network, divided into classes, and assigned the required class of service. Then packets are marked with a Differentiated Services Code Point (DSCP) tag to indicate the class of service to which they belong. The DSCP value is written into the TOS field of the IP header. Routers within the network then use this DSCP value to classify packets and assign QoS appropriately. When a packet leaves the DiffServ domain, the DSCP value can be replaced with a value appropriate for the next DiffServ domain.

A simple example of this process is shown in Figure 13, for limiting the amount of bandwidth used by traffic from a particular IP address. In the domain shown, this bandwidth limit is supplied by the class of service represented by a DSCP value of 40. In the next DiffServ domain, this traffic is assigned to the class of service represented by a DSCP value of 3.

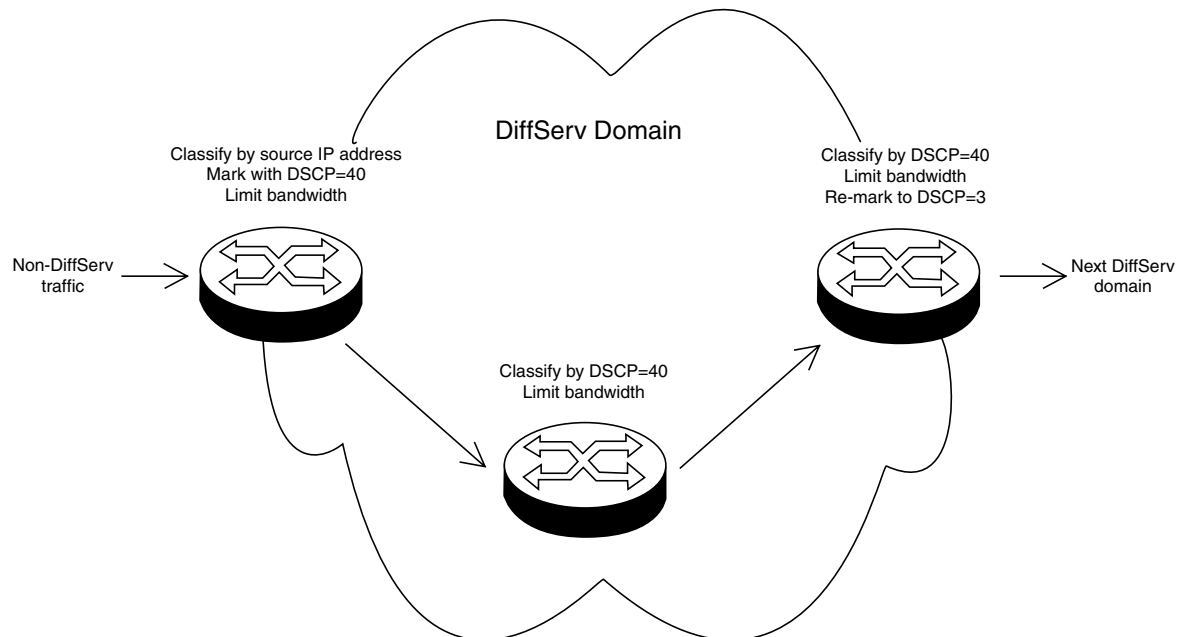

Figure 13. DiffServ Domain Example

To use the QoS tool set to configure a DiffServ domain:

1. As packets come into the domain at edge switches, replace their DSCP value, if required.
  - ❑ Classify the packets according to the required characteristics. For available options, see Chapter 11, “Classifiers” on page 125.
  - ❑ Assign the classifiers to flow groups and the flow groups to traffic classes, with a different traffic class for each DiffServ code point grouping within the DiffServ domain.
  - ❑ Give each traffic class the priority and/or bandwidth limiting controls that are required for that type of packet within this part of the domain.
  - ❑ Assign a DSCP value to each traffic class, to be written into the TOS field of the packet header.
2. On switches and routers within the DiffServ domain, classify packets according to the DSCP values that were assigned to traffic classes on the edge switches.
  - ❑ Assign the classifiers to flow groups and the flow groups to traffic classes, with a different traffic class for each DiffServ code point grouping within the DiffServ domain.
  - ❑ Give each traffic class the priority and/or bandwidth limiting controls that are required for that type of packet within this part of the domain. These QoS controls need not be the same for each switch.
3. As packets leave the DiffServ domain, classify them according to the DSCP values.
  - ❑ Assign the classifiers to flow groups and the flow groups to traffic classes, with a different traffic class for each DiffServ code point grouping within the DiffServ domain.
  - ❑ Give each traffic class the priority and/or bandwidth limiting controls required for transmission of that type of packet to its next destination, in accordance with any Service Level Agreement (SLA) with the providers of that destination.
  - ❑ If necessary, assign a different DSCP value to each traffic class, to be written into the TOS field of the packet header, to match the DSCP or TOS priority values of the destination network.



## Examples

---

The following examples demonstrate how to implement QoS in three situations:

- “Voice Applications,” next
- “Video Applications” on page 171
- “Critical Database” on page 173

### **Voice Applications**

Voice applications typically require a small but consistent bandwidth. They are sensitive to *latency* (interpacket delay) and *jitter* (delivery delay). Voice applications can be set up to have the highest priority.

This example creates two policies that ensure low latency for all traffic sent by and destined to a voice application located on a node with the IP address 149.44.44.44. The policies raise the priority level of the packets to 7, the highest level. Policy 6 is for traffic from the application that enter the switch on port 1. Policy 11 is for traffic arriving on port 8 going to the application. The components of the policies are shown in Figure 14.

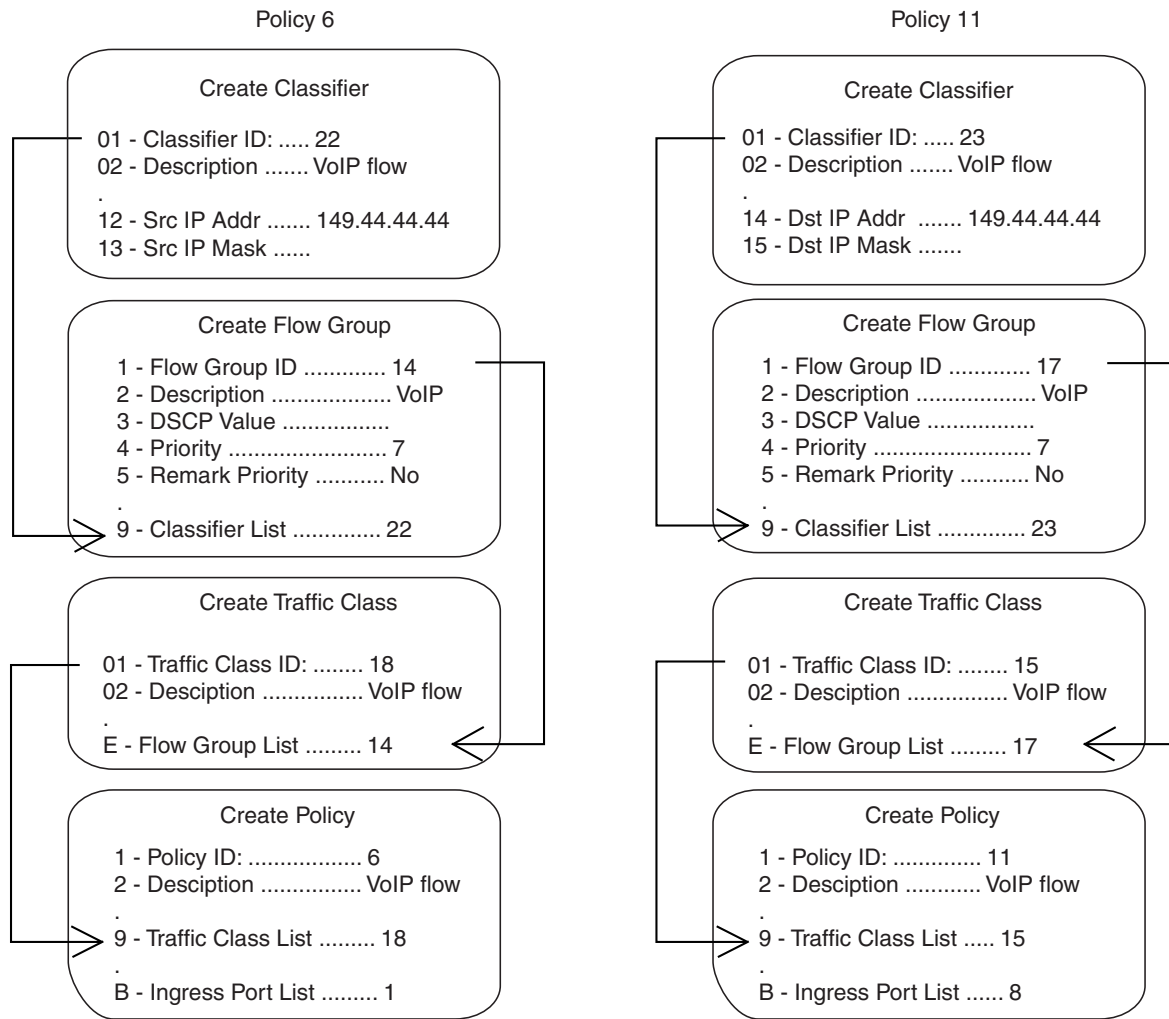

Figure 14. QoS Voice Application Example

The parts of the policies are:

- ❑ **Classifier** - Defines the traffic flow by specifying the IP address of the node with the voice application. The classifier for Policy 6 specifies the address as a source address because this classifier is part of a policy for packets coming from the application. The classifier for Policy 11 specifies the address as a destination address because this classifier is part of a policy for packets going to the application.
- ❑ **Flow Group** - Specifies the new priority level of 7 for the packets. In this example the packets leave the switch with the same priority level they had when they entered. The new priority level is relevant only as the packets traverse the switch. To change the packets' priority level so that they leave with the new level, you would change option 5, Remark Priority, to Yes.

- ❑ Traffic Class - No action is taken by the traffic class, other than to specify the flow group. Traffic class has a priority setting you can use to override the priority level of packets, just as in a flow group. If you enter a priority value in both places, the setting in the flow group overrides the setting in the traffic class.
- ❑ Policy - Specifies the traffic class and the port to which the policy is to be assigned. Policy 6 is applied to port 1 because this is where the application is located. Policy 11 is applied to port 8 because this is where traffic going to the application will be received.

## **Video Applications**

Video applications typically require a larger bandwidth than voice applications. Video applications can be set up to have a high priority and buffering, depending on the application.

This example creates policies with low latency and jitter for video streams (for example, net conference calls). The policies in Figure 15 assign the packets a priority level of 4. The policies also limit the bandwidth for the video streams to 5 Mbps to illustrate how you can combine a change to the priority level with bandwidth restriction to further define traffic control. The node containing the application has the IP address 149.44.44.44. Policy 17 is assigned to port 1, where the application is located, and Policy 32 is assigned to port 8 where packets destined to the application enter the switch.

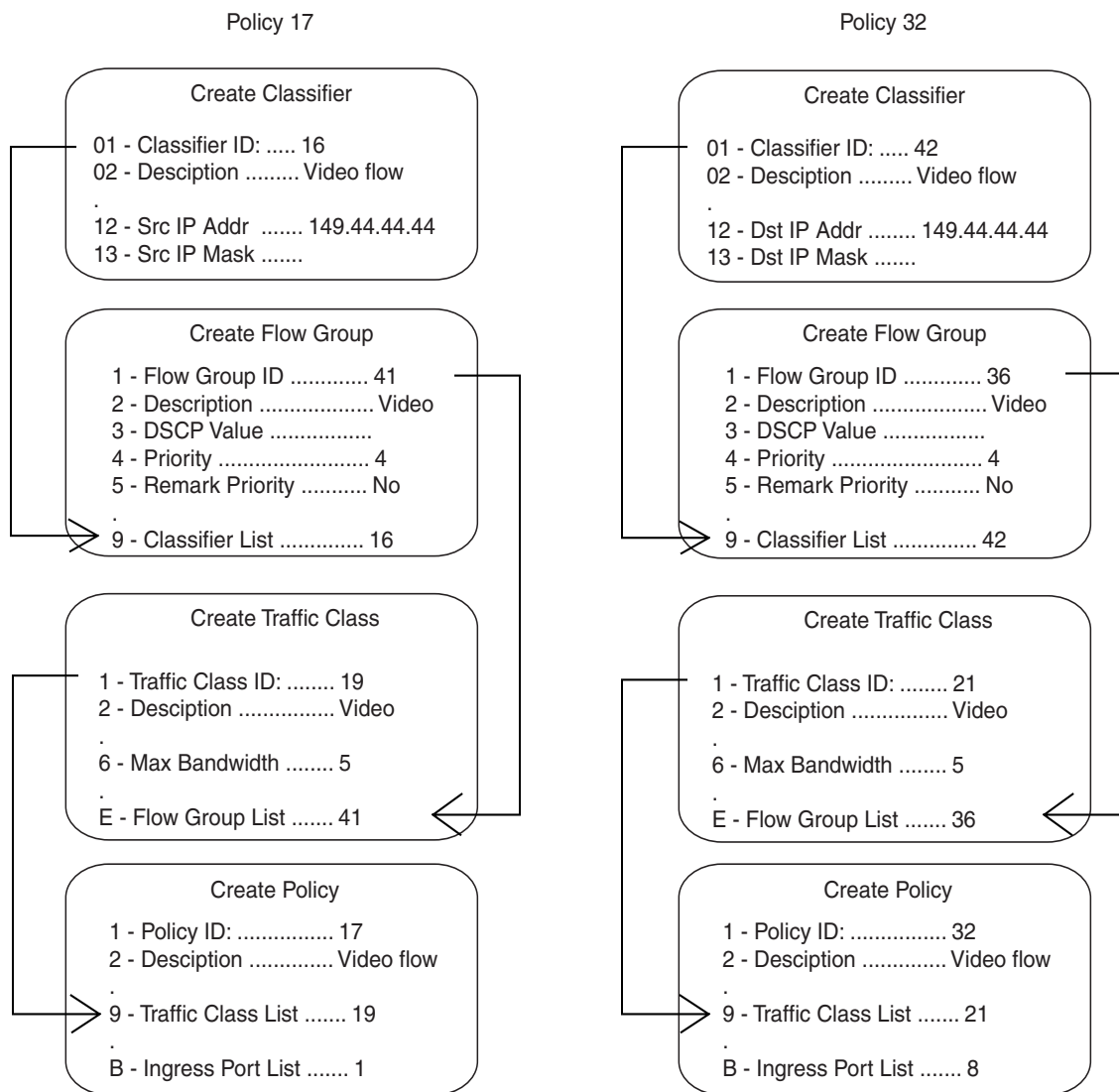

Figure 15. QoS Video Application Example

The parts of the policies are:

- ❑ Classifier - Specifies the IP address of the node with a video application. The classifier for Policy 17 specifies the address as a source address since this classifier is part of a policy concerning packets coming from the application. The classifier for Policy 32 specifies the address as a destination address because this classifier is part of a policy concerning packets going to the application.
- ❑ Flow Group - Specifies the new priority level of 4 for the packets. As with the previous example, the packets leave the switch with the same priority level they had when they entered. The new priority level is relevant only while the packets traverse the switch. To alter the

packets so they leave containing the new level, you would change option 5, Remark Priority, to Yes.

- ❑ Traffic Class - The packet stream is assigned a maximum bandwidth of 5 Mbps. Bandwidth assignment can only be made at the traffic class level.
- ❑ Policy - Specifies the traffic class and the port where the policy is to be assigned.

**Critical Database**

Critical databases typically require a high bandwidth. They also typically require less priority than either voice or video.

The policies in Figure 16 assign 50 Mbps bandwidth, with no change to priority, to traffic going to and from a database. The database is located on a node with the IP address 149.44.44.44 on port 1 of the switch.

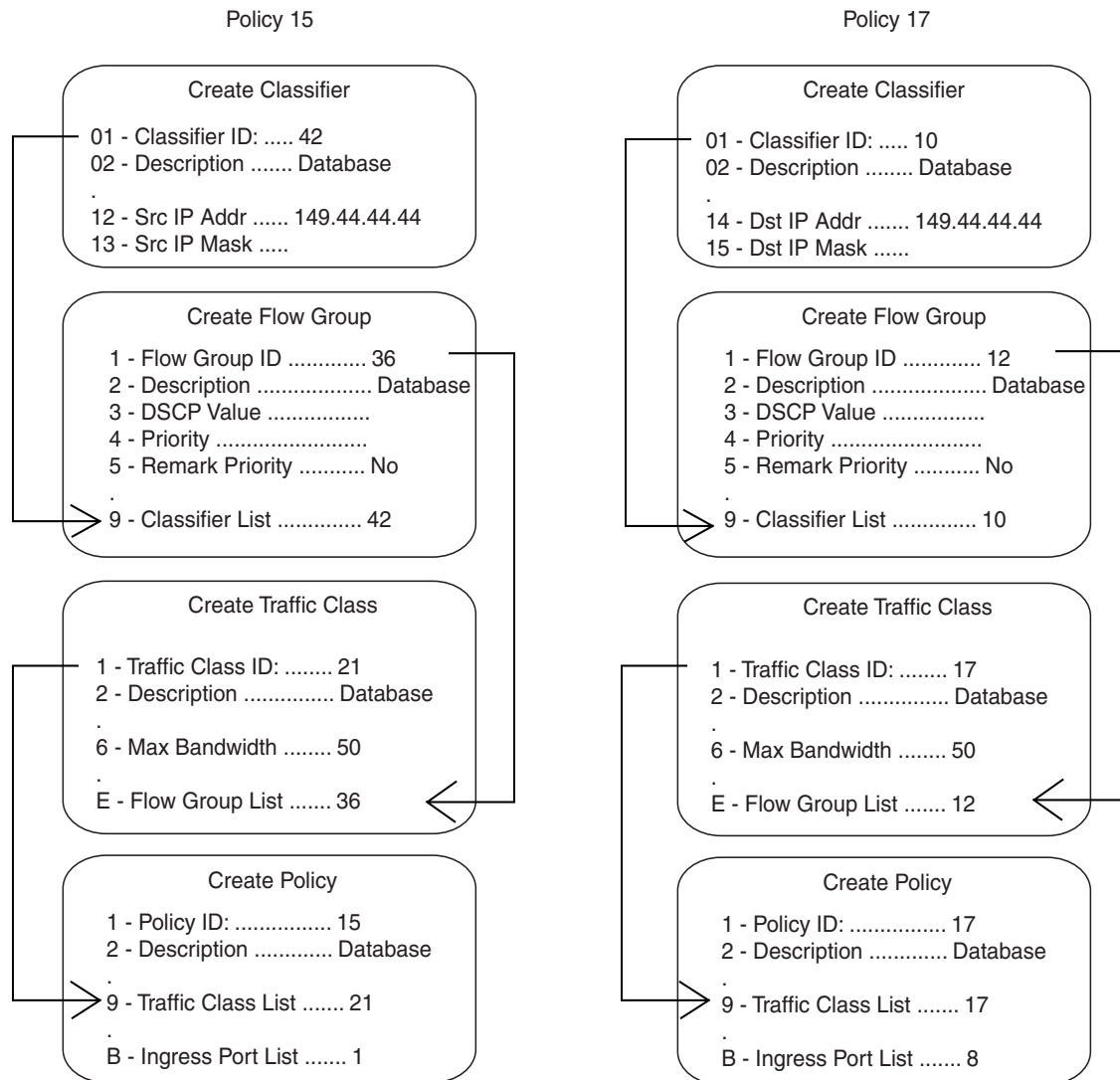

Figure 16. QoS Critical Database Example

## Policy Component Hierarchy

The purpose of this example is to illustrate the hierarchy of the components of a QoS policy and how that hierarchy needs to be taken into account when assigning new priority and DSCP values. A new priority can be set at the flow group and traffic class levels, while a new DSCP value can be set at all three levels—flow group, traffic class and policy. The basic rules are:

- ❑ A new setting in a flow group takes precedence over a corresponding setting in a traffic class or policy.
- ❑ A new setting in a traffic class takes precedence over a corresponding setting in a policy.
- ❑ A new setting in a policy is used only if there is no corresponding setting in a flow group or traffic class.

This concept is illustrated in Figure 17 on page 175. It shows a policy for a series of traffic flows consisting of subnets defined by their destination IP addresses. New DSCP values for the traffic flows are established at different levels within the policy.

Traffic flows 149.11.11.0 and 149.22.22.0, defined by classifiers 1 and 2, are attached to a flow group, traffic class, and policy that contain new DSCP values. Because a setting in a flow group takes precedence over that of a traffic class or policy, the value in the flow group is used. The result is that the DSCP value in the two traffic flows is changed to 10.

The flow group for traffic flows 149.33.33.0 and 149.44.44.0, defined in classifiers 3 and 4, does not contain a new DSCP value. Therefore, the new value in the traffic class is used, in this case 30. The policy also has a DSCP setting, but it is not used for these traffic flows because a new DSCP setting in a traffic class takes precedence over that of a policy.

Finally, the new DSCP value for traffic flows 149.55.55.0 and 149.66.66.0, defined in classifiers 5 and 6, is set at the policy level to a value of 55 because the flow group and traffic class do not specify a new value.

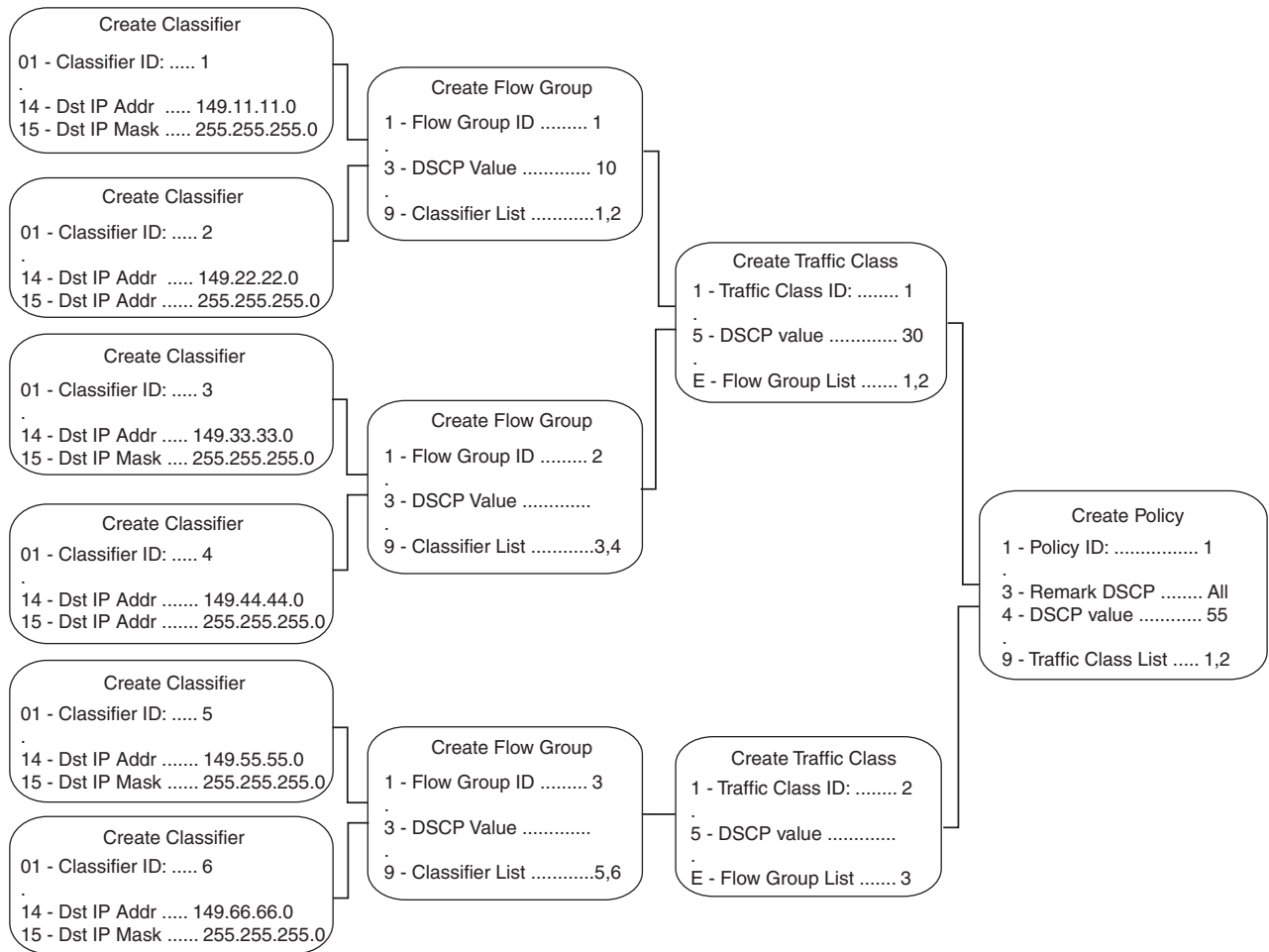

Figure 17. Policy Component Hierarchy Example





## Chapter 15

# Denial of Service Defenses

---

This chapter explains the defense mechanisms in the management software that can protect your network against denial of service (DoS) attacks. Sections in the chapter include:

- ❑ “Supported Platforms” on page 178
- ❑ “Overview” on page 179
- ❑ “SYN Flood Attack” on page 180
- ❑ “Smurf Attack” on page 181
- ❑ “Land Attack” on page 182
- ❑ “Teardrop Attack” on page 184
- ❑ “Ping of Death Attack” on page 185
- ❑ “IP Options Attack” on page 186
- ❑ “Mirroring Traffic” on page 187
- ❑ “Denial of Service Defense Guidelines” on page 188

## Supported Platforms

---

Refer to Table 54 and Table 55 for the AT-9400 Switches and the management interfaces that support the denial of service defenses.

Table 54. Support for the Denial of Service Defenses

Switch	Supported
Layer 2+ Models	
AT-9408LC/SP	Yes
AT-9424T/GB	Yes
AT-9424T/SP	Yes
Basic Layer 3 Models	
AT-9424T	Yes
AT-9424T/POE	Yes
AT-9424Ts	Yes
AT-9424Ts/XP	Yes
AT-9448T/SP	Yes
AT-9448Ts/XP	Yes
AT-9400Ts Stack	

Table 55. Management Interfaces for the Denial of Service Defenses

Switch or Stack	Standard Command Line	AlliedWare Plus Command Line	Menus	Web Browser
Stand-alone Switch	Yes		Yes	Yes
AT-9400Ts Stack				

## Overview

---

The AT-S63 Management Software can help protect your network against the following types of denial of service attacks.

- ❑ SYN Flood Attack
- ❑ Smurf Attack
- ❑ Land Attack
- ❑ Teardrop Attack
- ❑ Ping of Death Attack
- ❑ IP Options Attack

The following sections describe each type of attack and the mechanism employed by the AT-S63 Management Software to protect your network.

---

**Note**

Be sure to read the following descriptions before implementing a DoS defense on a switch. Some defense mechanisms are CPU intensive and can impact switch behavior.

---

## SYN Flood Attack

---

In this type of attack, an attacker sends a large number of TCP connection requests (TCP SYN packets) with bogus source addresses to the victim. The victim responds with acknowledgements (SYN ACK packets), but because the original source addresses are bogus, the victim node does not receive any replies. If the attacker sends enough requests in a short enough period, the victim may freeze operations when the number of requests exceeds the capacity of its connections queue.

To defend against this form of attack, a switch port monitors the number of ingress TCP connection requests it receives. If a port receives more than 60 requests per second, the following occurs.

- ❑ The switch sends an SNMP trap to the management stations
- ❑ The switch port is blocked for one minute.

This defense mechanism does not involve the switch's CPU. You can activate it on some or all of the ports without impacting switch performance.

## Smurf Attack

---

This DoS attack is instigated by an attacker sending a ICMP Echo (Ping) request that has the network's IP broadcast address as the destination address and the address of the victim as the source of the ICMP Echo (Ping) request. This overwhelms the victim with a large number of ICMP Echo (Ping) replies from the other network nodes.

A switch port defends against this form of attack by examining the destination IP addresses of ingress ICMP Echo (Ping) request packets and discarding those that contain the network's IP broadcast address as a destination address.

To implement this defense, you must specify an IP address of a node on your network and a mask. The switch uses the two to determine the broadcast address of your network.

This defense mechanism does not involve the switch's CPU. You can activate it on some or all of the ports without impacting switch performance.

## Land Attack

---

In this attack, an attacker sends a bogus IP packet where the source and destination IP addresses are the same. This leaves the victim thinking that it is sending a message to itself.

The most direct approach for defending against this form of attack is for the AT-S63 Management Software to check the source and destination IP addresses in the IP packets, searching for and discarding those with identical source and destination addresses. However, this would require too much processing by the switch's CPU and would adversely impact switch performance.

Instead, the switch examines the IP packets that are entering and leaving your network. IP packets that are generated within your network and contain a local IP address as the destination address are not allowed to leave the network, and IP packets that are generated outside the network but contain a local IP address as the source address are not allowed into the network.

In order for this defense mechanism to work, you need to specify an uplink port. This is the port on the switch that is connected to a device, such as a DSL router, that leads outside your network. You can specify only one uplink port.

---

**Note**

You should not use this defense mechanism on a switch that is not connected to a device that leads outside your network.

---

You also need to enter the IP address of one of your network devices as well as a mask which the switch uses to differentiate between the network portion and node portion of the address. The switch uses the IP address and mask to determine which IP addresses are local to your network and which are from outside you network.

The following is a overview of how the process works. This example assumes that you have activated the feature on port 4, which is connected to a device local to your network, and that you specified port 1 as the uplink port, which is connected to the device that leads outside your network. The steps below review what happens when an ingress IP packet from the local device arrives on port 4:

1. When port 4 receives an ingress IP packet with a destination MAC address learned on uplink port 1, it examines the packet's source IP address.

2. If the source IP address is not local to the network, it discards the packet because it assumes that a packet with an IP address that is not local to the network should not be appearing on a port that is not an uplink port. This protects against the possibility of a Land attack originating from within your network.
3. If the source IP address is local to the network, the port forwards the packet to uplink port 1.

Below is a review of how the process takes place when an ingress IP packet arrives on uplink port 1 that is destined for port 4:

1. When uplink port 1 receives an ingress IP packet with a destination MAC address that was learned on port 4, it examines the packet's source IP address before forwarding the packet.
2. If the source IP address is local to the network, uplink port 1 does not forward the packet to port 4 because it assumes that a packet with a source IP address that is local to the network should not be entering the network from outside the network on the uplink port.
3. If the source IP address is not local to the network, port 1 forwards the packet to port 4.

The following guidelines apply to using this defense mechanism:

- If you choose to use it, Allied Telesis recommends activating it on all ports on the switch, including the uplink port.
- You can specify only one uplink port.
- You must specify the IP address of one of the network nodes, preferably the lowest IP address, and a mask.

This form of defense is not CPU intensive. Activating it on all ports should not affect switch behavior.

## Teardrop Attack

---

An attacker sends an IP packet in several fragments with a bogus offset value, used to reconstruct the packet, in one of the fragments to a victim. Because of the bogus offset value, the victim is unable to reassemble the packet, possibly causing it to freeze operations.

The defense mechanism for this type of attack has all ingress fragmented IP traffic received on a port sent to the switch's CPU. The CPU samples related, consecutive fragments, checking for fragments with invalid offset values.

If one is found, the following occurs:

- The switch sends an SNMP trap to the management stations.
- The switch port is blocked for one minute.

Because the CPU only samples the ingress IP traffic, this defense mechanism may not catch all occurrences of this form of attack.



### Caution

This defense is extremely CPU intensive; use with caution. Unrestricted use can cause a switch to halt operations if the CPU becomes overwhelmed with IP traffic. To prevent this, Allied Telesis recommends activating this defense on only the uplink port and one other switch port at a time.

---



## Ping of Death Attack

---

The attacker sends an oversized, fragmented ICMP Echo (Ping) request (greater than 65,535 bits) to the victim, which, if lacking a policy for handling oversized packets, may freeze.

To defend against this form of attack, a switch port searches for the last fragment of a fragmented ICMP Echo (Ping) request and examines its offset to determine if the packet size is greater than 63,488 bits. If it is, the fragment is forwarded to the switch's CPU for final packet size determination. If the switch determines that the packet is oversized, the following occurs:

- ❑ The switch sends an SNMP trap to the management stations.
- ❑ The switch port is blocked for one minute.

---

### Note

This defense mechanism requires some involvement by the switch's CPU, though not as much as the Teardrop defense. This does not impact the forwarding of traffic between the switch ports, but it can affect the handling of CPU events, such as the processing of IGMP packets and spanning tree BPDUs. For this reason, Allied Telesis recommends limiting the use of this defense, activating it only on those ports where an attack is most likely to originate.

---

Also note that an attacker can circumvent the defense by sending a stream of ICMP Echo (Ping) requests with a size of 63,488 to 65,534 bits. A large number of requests could overwhelm the switch's CPU.

## IP Options Attack

---

In the basic scenario of an IP attack, an attacker sends packets containing bad IP options. There are several types of IP option attacks and the AT-S63 Management Software does not distinguish between them.

Rather, the defense mechanism counts the number of ingress IP packets containing IP options received on a port. If the number exceeds 20 packets per second, the switch considers this a possible IP options attack and the following occurs:

- ❑ It sends an SNMP trap to the management stations.
- ❑ The switch port is blocked for one minute.

This defense mechanism does not involve the switch's CPU. You can activate it on as many ports as you want without it impacting switch performance.

---

### **Note**

This defense does not actually check IP packets for bad IP options, and so can only alert you to a *possible* attack.

---

## Mirroring Traffic

---

The Land, Teardrop, Ping of Death, and IP Options defense mechanisms allow you to copy the examined traffic to a mirror port for further analysis with a data sniffer or analyzer. This feature differs slightly from port mirroring in that prior to an actual violation of a defense mechanism, only the packets examined by a defense mechanism, rather than all packets, are mirrored to the destination port. Should a violation occur, then all ingress packets on the port where the violation occurred are mirrored.

As an example, activating the mirroring feature in conjunction with the Teardrop defense on a port sends all examined ingress fragmented IP traffic to the destination mirror port. If the switch detects a violation, all ingress packets on the port are copied to the mirror port during the sixty seconds that the port is blocked.

Implementing this feature requires configuring the port mirroring feature as follows:

- Activate port mirroring.
- Specify a destination port.
- Do not specify any source ports. The source ports are defined by the Denial of Service defense mechanism.

## Denial of Service Defense Guidelines

---

Below are guidelines to observe when using this feature:

- ❑ A switch port can support more than one DoS defense at a time.
- ❑ The Teardrop and the Ping of Death defenses are CPU intensive. Use these defenses with caution.

## Chapter 16

# Power Over Ethernet

---

This chapter contains background information on Power over Ethernet (PoE) for the AT-9424T/POE Switch. Sections in the chapter include:

- ❑ “Supported Platforms” on page 190
- ❑ “Overview” on page 191
- ❑ “Power Budgeting” on page 192
- ❑ “Port Prioritization” on page 193
- ❑ “PoE Device Classes” on page 194

---

**Note**

This chapter applies only to the AT-9424T/POE Switch.

---

## Supported Platforms

---

Refer to Table 56 and Table 57 for the AT-9400 Switch and the management interfaces that support the Power over Ethernet feature.

Table 56. Support for the Power Over Ethernet Feature

Switch	Supported
Layer 2+ Models	
AT-9408LC/SP	
AT-9424T/GB	
AT-9424T/SP	
Basic Layer 3 Models	
AT-9424T	
AT-9424T/POE	Yes
AT-9424Ts	
AT-9424Ts/XP	
AT-9448T/SP	
AT-9448Ts/XP	
AT-9400Ts Stack	

Table 57. Management Interfaces for the Power Over Ethernet Feature

Switch or Stack	Standard Command Line	AlliedWare Plus Command Line	Menus	Web Browser
Stand-alone Switch	Yes		Yes	
AT-9400Ts Stack				

## Overview

---

Power over Ethernet (PoE) is a mechanism for supplying power to network devices over the same twisted pair cables that carry the network traffic. This feature, defined in the IEEE 802.3af standard, can make the installation and maintenance of a network easier.

The device that provides the power, in this case the AT-9424T/POE Switch, acts as a central power source for other network devices. A device that receives its power from the central power source is called a *powered device*. Examples include wireless access points, IP telephones, webcams, and even other Ethernet switches, such as the unmanaged AT-FS705PD Ethernet switch from Allied Telesis.

One of the advantages that the PoE feature offers is that it can simplify the installation of your network. The selection of a location for a network device is often limited by whether there is a power source nearby. This often limits equipment placement or requires the added time and cost of having additional electrical sources installed. But with PoE, you can install PoE-compatible devices wherever they are needed without having to worry about whether there are power sources nearby.

This feature can also add to the reliability of a network. Since the switch acts as the central power source for your powered devices, adding a redundant power supply (RPS) or uninterruptible power source (UPS) to the device increases the protection not just to the switch from possible power source problems but also to all of the powered devices connected to it.

The switch automatically determines whether or not the devices connected to the ports are powered devices. Ports that are connected to network nodes that are not powered devices (that is, devices that receive their power from another power source) function as regular Ethernet ports, without PoE. The PoE feature remains activated on the ports but no power is delivered to the devices.

The IEEE 802.3af standard defines two methods for implementing PoE over twisted pair cabling. One method uses the same strands that carry the network traffic and the other the spare strands. The ports on the AT-9424T/POE Switch deliver the power using strands 1, 2, 3, and 6 of the twisted pair cable. These are the same strands that carry the Ethernet traffic. This corresponds to Alternative A in the IEEE 802.3af standard.

## Power Budgeting

---

The AT-9424T/POE Switch has a maximum power budget of 380 watts. The maximum possible load on the switch from the powered devices is 360W. The latter number assumes that all of the twenty four ports are connected to powered devices that are drawing the maximum of 15.4 W per port. Given that the power budget of the switch exceeds the highest possible load, it should be possible to connect powered devices to all of the ports without exceeding the power budget. However, you can disable PoE on a per-port basis or reduce the maximum amount of power a port will deliver, from the maximum of 15.4 W. The default setting for PoE on the switch is enabled on all ports.



## Port Prioritization

---

Port prioritization is used to control which ports on the switch are to receive PoE in the event the power requirements of the devices exceed the switch's power budget. Port prioritization should be unnecessary on the AT-9424T/POE Switch since its power supply can deliver the maximum of 15.4 W to all of its twenty four ports simultaneously.

If the power requirements of the powered devices exceeds the switch's power budget, the switch will deny power to some ports based on a system called port prioritization. You can use this mechanism to ensure that powered devices critical to the operations of your network are given preferential treatment by the switch in the distribution of power should the demands of the devices exceed the available capacity.

There are three priority levels:

- Critical
- High
- Low

The Critical level is the highest priority level. Ports set to this level are guaranteed power before any of the ports assigned to the other two priority levels. Ports assigned to the other priority levels receive power only if all the Critical ports are receiving power. Your most critical powered devices should be assigned to this level. If there is not enough power to support all the ports set to the Critical priority level, power is provided to the ports based on port number, in ascending order.

The High level is the second highest level. Ports set to this level receive power only if all the ports set to the Critical level are already receiving power. If there is not enough power to support all of the ports set to the High priority level, power is provided to the ports based on port number, in ascending order.

The lowest priority level is Low. This is the default setting. Ports set to this level only receive power if all the ports assigned to the other two levels are already receiving power. As with the other levels, if there is not enough power to support all of the ports set to the Low priority level, power is provided to the ports based on port number, in ascending order.

Power allocation is dynamic. Ports supplying power to powered devices may cease power transmission if the switch's power budget has reached maximum usage and new powered devices, connected to ports with a higher priority, become active.

## PoE Device Classes

---

The IEEE 802.3af standard specifies four levels of classes for powered devices that are defined by power usage. The classes are:

- ❑ 0 - 0.44 W to 12.95 W
- ❑ 1 - 0.44 W to 3.84 W
- ❑ 2 - 3.84 W to 6.49 W
- ❑ 3 - 6.49 W to 12.95 W

(The standard actually specifies five levels; the fifth is reserved for future use.)

The class of a powered device is set by the manufacturer and it cannot be changed. This is mentioned here because you can view the classes of the powered devices through the switch's management software.

According to the IEEE standard, the maximum amount of power a powered device should consume is 12.95 W. However, the ports on the switch can deliver up to 15.4 W. The reason for the difference is because some power is lost on the twisted pair cable as it travels from the switch to a powered device. For those devices needing 12.95 W, the extra watts act as compensation for the possible loss.

## Section III

# Snooping Protocols

---

The chapters in this section contain overview information on the snooping protocols. The chapters include:

- ❑ Chapter 17, "Internet Group Management Protocol Snooping" on page 197
- ❑ Chapter 18, "Multicast Listener Discovery Snooping" on page 201
- ❑ Chapter 19, "Router Redundancy Protocol Snooping" on page 205
- ❑ Chapter 20, "Ethernet Protection Switching Ring Snooping" on page 209



## Chapter 17

# Internet Group Management Protocol Snooping

---

This chapter explains the Internet Group Management Protocol (IGMP) snooping feature in the following sections:

- ❑ “Supported Platforms” on page 198
- ❑ “Overview” on page 199

## Supported Platforms

---

Refer to Table 58 and Table 59 for the AT-9400 Switches and the management interfaces that support the Internet Group Management Protocol (IGMP) snooping feature.

Table 58. Support for Internet Group Management Protocol Snooping

Switch	Supported
Layer 2+ Models	
AT-9408LC/SP	Yes
AT-9424T/GB	Yes
AT-9424T/SP	Yes
Basic Layer 3 Models	
AT-9424T	Yes
AT-9424T/POE	Yes
AT-9424Ts	Yes
AT-9424Ts/XP	Yes
AT-9448T/SP	Yes
AT-9448Ts/XP	Yes
AT-9400Ts Stack	Yes

Table 59. Management Interfaces for Internet Group Management Protocol Snooping

Switch or Stack	Standard Command Line	AlliedWare Plus Command Line	Menus	Web Browser
Stand-alone Switch	Yes	Yes	Yes	Yes
AT-9400Ts Stack	Yes	Yes		Yes

## Overview

---

IPv4 routers use IGMP to create lists of nodes that are members of multicast groups. (A multicast group is a group of end nodes that want to receive multicast packets from a multicast application.) The router creates a multicast membership list by periodically sending out queries to the local area networks connected to its ports.

A node wanting to become a member of a multicast group responds to a query by sending a *report*. A report indicates an end node's desire to become a member of a multicast group. Nodes that join a multicast group are referred to as *host nodes*. After becoming a member of a multicast group, a host node must continue to periodically issue reports to remain a member.

After the router has received a report from a host node, it notes the multicast group that the host node wants to join and the port on the router where the node is located. Any multicast packets belonging to that multicast group are then forwarded by the router out the port. If a particular port on the router has no nodes that want to be members of multicast groups, the router does not send multicast packets out the port. This improves network performance by restricting multicast packets only to router ports where host nodes are located.

There are three versions of IGMP — versions 1, 2, and 3. One of the differences between the versions is how a host node signals that it no longer wants to be a member of a multicast group. In version 1 it stops sending reports. If a router does not receive a report from a host node after a predefined length of time, referred to as a *time-out value*, it assumes that the host node no longer wants to receive multicast frames, and removes it from the membership list of the multicast group.

In version 2 a host node exits from a multicast group by sending a *leave request*. After receiving a leave request from a host node, the router removes the node from appropriate membership list. The router also stops sending multicast packets out the port to which the node is connected if it determines there are no further host nodes on the port.

Version 3 adds the ability of host nodes to join or leave specific sources in a multicast group.

The IGMP snooping feature on the AT-9400 Switch supports all three versions of IGMP. The switch monitors the flow of queries from routers and reports and leave messages from host nodes to build its own multicast membership lists. It uses the lists to forward multicast packets only to switch ports where there are host nodes that are members of multicast groups. This improves switch performance and network security by restricting the flow of multicast packets only to those switch ports connected to host nodes.

Without IGMP snooping a switch would have to flood multicast packets out all of its ports, except the port on which it received the packet. Such flooding of packets can negatively impact network performance.

The AT-9400 Switch maintains its list of multicast groups through an adjustable timeout value, which controls how frequently it expects to see reports from end nodes that want to remain members of multicast groups, and by processing leave requests.

---

**Note**

The default setting for IGMP snooping on the switch is disabled.

---



## Chapter 18

# Multicast Listener Discovery Snooping

---

This chapter explains Multicast Listener Discovery (MLD) snooping:

- ❑ “Supported Platforms” on page 202
- ❑ “Overview” on page 203

## Supported Platforms

---

Refer to Table 60 and Table 61 for the AT-9400 Switches and the management interfaces that support Multicast Listener Discovery snooping.

Table 60. Support for Multicast Listener Discovery Snooping

Switch	Supported
Layer 2+ Models	
AT-9408LC/SP	Yes
AT-9424T/GB	Yes
AT-9424T/SP	Yes
Basic Layer 3 Models	
AT-9424T	Yes
AT-9424T/POE	Yes
AT-9424Ts	Yes
AT-9424Ts/XP	Yes
AT-9448T/SP	Yes
AT-9448Ts/XP	Yes
AT-9400Ts Stack	

Table 61. Management Interfaces for Multicast Listener Discovery Snooping

Switch or Stack	Standard Command Line	AlliedWare Plus Command Line	Menus	Web Browser
Stand-alone Switch	Yes		Yes	
AT-9400Ts Stack				

## Overview

---

MLD snooping performs the same function as IGMP snooping. The switch uses the feature to build multicast membership lists. It uses the lists to forward multicast packets only to switch ports where there are host nodes that are members of the multicast groups. The difference between the two is that MLD snooping is for IPv6 and IGMP snooping for IPv4 environments. (For background information on IGMP snooping, refer to “Overview” on page 199.)

There are two versions of MLD. MLDv1 is equivalent to IGMPv2 and MLDv2 is equivalent to IGMPv3. The AT-9400 Switch supports snooping of both MLDv1 and MLDv2.

---

**Note**

The default setting for MLD snooping on the switch is disabled.

---



## Chapter 19

# Router Redundancy Protocol Snooping

---

This chapter explains Router Redundancy Protocol (RRP) snooping and contains the following sections:

- ❑ “Supported Platforms” on page 206
- ❑ “Overview” on page 207
- ❑ “Guidelines” on page 208

## Supported Platforms

---

Refer to Table 62 and Table 63 for the AT-9400 Switches and the management interfaces that support Router Redundancy Protocol Snooping.

Table 62. Support for Router Redundancy Protocol Snooping

Switch	Supported
Layer 2+ Models	
AT-9408LC/SP	Yes
AT-9424T/GB	Yes
AT-9424T/SP	Yes
Basic Layer 3 Models	
AT-9424T	Yes
AT-9424T/POE	Yes
AT-9424Ts	Yes
AT-9424Ts/XP	Yes
AT-9448T/SP	Yes
AT-9448Ts/XP	Yes
AT-9400Ts Stack	

Table 63. Management Interfaces for Router Redundancy Protocol Snooping

Switch or Stack	Standard Command Line	AlliedWare Plus Command Line	Menus	Web Browser
Stand-alone Switch	Yes		Yes	
AT-9400Ts Stack				

## Overview

---

The Router Redundancy Protocol (RRP) allows multiple routers to share the same virtual IP address and MAC address. In network topologies where redundant router paths or links exist, the protocol enables routers, through an election process, to designate one as the master router. This router functions as the provider of the primary path between LAN segments. Slave routers function as backup paths in the event that the master router or primary path fails.

Because the master and slave routers are able to share the same virtual IP address and MAC address, a change in data paths need not necessitate an adjustment to the default gateways on the network nodes that employ the routers. When a slave router transitions to master, it uses the same IP address as the previous master router, making the transition transparent to the network end nodes. In large networks, these transparent transitions can save the time and effort of having to manually reconfigure default gateway addresses on large numbers of network nodes when a router pathway fails.

RRP snooping on the AT-9400 Switch facilitates the transition to a new master router by minimizing the loss of traffic, and so reduces the impact the transition could have on your network traffic. RRP snooping monitors ingress RRP packets, determined by their source MAC address. Source MAC addresses considered by the AT-S63 Management Software as RRP packets are:

- ❑ 00:E0:2B:00:00:80-9F
- ❑ 00:A0:D2EB:FF:00
- ❑ 00:00:5E:00:01:00-FF

A port receiving an RRP packet is deemed by the switch as the master RRP port. The virtual MAC address of the router is entered as a dynamic address on the port. If the switch starts to receive RRP packets on another port, it assumes that a backup or slave router has made the transition to the role of the new master router.

The switch responds by deleting all dynamic MAC addresses from the MAC address table. As the switch relearns the addresses, the virtual MAC address of the new master router is learned on the new master RRP port, rather than the old port. Any packets received by the switch and destined for the router are forwarded to the new master router.

## Guidelines

---

The following guidelines apply to the RRP snooping feature:

- ❑ The default setting for this feature is disabled.
- ❑ Activating the feature flushes all dynamic MAC addresses from the MAC address table.
- ❑ RRP snooping is supported on ports operating in the MAC address-based port security level of automatic. This feature is not supported on ports operating with a security level of limited, secured, or locked.
- ❑ RRP snooping is supported on port trunks.



## Chapter 20

# Ethernet Protection Switching Ring Snooping

---

This chapter has the following sections:

- ❑ “Supported Platforms” on page 210
- ❑ “Overview” on page 211
- ❑ “Restrictions” on page 213
- ❑ “Guidelines” on page 215

## Supported Platforms

---

Refer to Table 64 and Table 65 for the AT-9400 Switches and the management interfaces that support Ethernet Protection Switching Ring Snooping.

Table 64. Support for Ethernet Protection Switching Ring Snooping

Switch	Supported
Layer 2+ Models	
AT-9408LC/SP	
AT-9424T/GB	
AT-9424T/SP	
Basic Layer 3 Models	
AT-9424T	Yes
AT-9424T/POE	Yes
AT-9424Ts	Yes
AT-9424Ts/XP	Yes
AT-9448T/SP	Yes
AT-9448Ts/XP	Yes
AT-9400Ts Stack	

Table 65. Management Interfaces for Ethernet Protection Switching Ring Snooping

Switch or Stack	Standard Command Line	AlliedWare Plus Command Line	Menus	Web Browser
Stand-alone Switch	Yes			
AT-9400Ts Stack				

## Overview

---

Ethernet Protection Switching Ring is a feature found on selected Allied Telesis products, such as the AT-x900 Advanced Layer 3 Switches. It offers an effective alternative to spanning tree based options when using ring based topologies to create high speed resilient networks.

EPSR consists of a master node and a number of transit nodes in a ring configuration. The master node monitors the health of the ring by transmitting healthcheck messages from a primary port at regular intervals over a control VLAN, and watching for the messages on a secondary port. If the healthcheck messages fail to arrive, the master node commences fault recovery of the ring by activating the secondary port so that connectivity between the transit nodes is maintained through the master node. When the integrity of the ring is restored, and the healthcheck messages can again traverse the entire ring, the master switch returns the secondary port to the blocking state.

---

**Note**

For background information and configuration examples of EPSR, refer to the *AlliedWare OS Software Reference Guide*.

---

EPSR snooping gives the AT-9400 Switch the ability to function as a transit node of a ring, but with restrictions, as explained in the next section. The switch can forward healthcheck messages over the control VLAN from the master node and respond appropriately when notified of a ring fault by the master node.

The master node generates a variety of messages over the control VLAN for monitoring the health of the ring and for notifying the nodes of changes to the ring's status. Two of these messages are the Ring-Down-Flush-FDB and Ring-Up-Flush-FDB messages. The first message notifies the nodes of a ring fault condition and the second signals the reestablishment of the ring.

The AT-9400 Switch and EPSR snooping react to these messages by flushing the addresses learned on the two ring ports of the control VLAN from the forwarding database, so that the switch can relearn the addresses. These are the only two EPSR messages that EPSR snooping can react to. It should be noted that EPSR snooping cannot generate any EPSR messages itself.

To configure the AT-9400 Switch as a transit node you need to create the control and data VLANs of the individual ring domains. As explained in the EPSR chapter in the *AlliedWare OS Software Reference Guide*, several domains can share the same physical network, but they must operate as logically separate VLAN groups. For information on VLANs, refer to Chapter 24, "Port-based and Tagged VLANs" on page 269.

After creating the VLANs, you activate EPSR snooping by specifying the control VLAN with the `ENABLE EPSRSNOOPING` command. The switch immediately begins to monitor the VLAN for control messages from the master switch and reacts accordingly should it receive EPSR messages on one of the two ports of the VLAN.

## Restrictions

---

EPSR snooping has three important restrictions. All the restrictions are related to control EPSR messages and the fact that EPSR snooping can not generate these messages.

The AT-9400 Switch cannot fulfill the role of master node of a ring because EPSR snooping does not generate EPSR control messages. That function must be assigned to another Allied Telesis switch that supports EPSR, such as the AT-x900 Advanced Layer 3 Switches. (For a list of Allied Telesis products that support EPSR, refer to the company's web site or contact your sales representative.)

The second restriction is EPSR snooping does not support the transit node unsolicited method of fault detection. When a break occurs in a ring, the transit nodes on either side of the break can notify the master node by sending a "links down" message over the control VLAN of the ring. This method of fault detection and notification can be a faster way for the master node to become aware of a problem than with the healthcheck message. However, since EPSR snooping can not generate the "links down" message, the AT-9400 Switch can not initiate this type of fault notification.

The final restriction of EPSR snooping concerns how the switch responds in the unlikely event it becomes isolated by disruptions in the ring on either side of it. Because the switch can not generate the EPSR "links up" message, a failure of a ring at two or more places may leave the AT-9400 Switch and EPSR snooping isolated until all of the breaks have been repaired and the entirety of the ring is restored.

The problem is illustrated in Figure 18. The example is a ring of four nodes: a master switch, two transit nodes, and the AT-9400 Switch running EPSR snooping. The ring has a control VLAN along with one or more data VLANs. The AT-9400 Switch is isolated from the ring because of two breaks, one between it and the master node and another between it and a transit node.

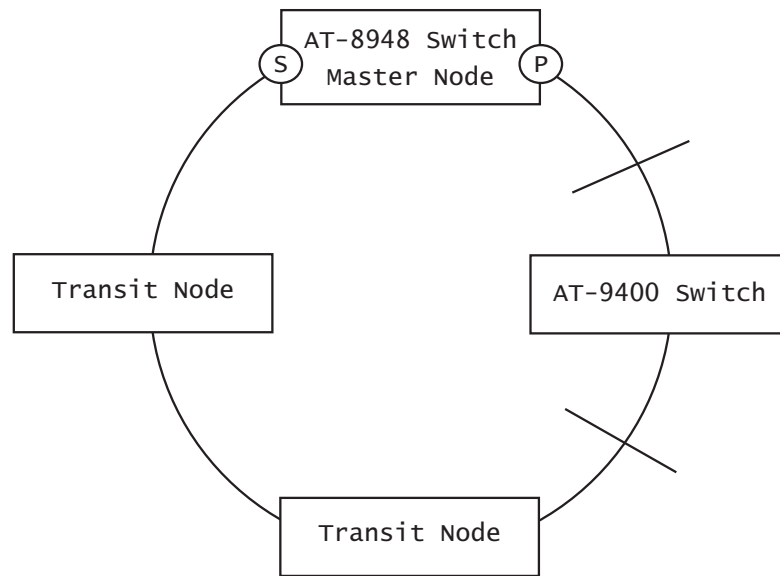

Figure 18. Double Fault Condition in EPSR Snooping

Now assume the link is reestablished between the switch and transit node. At that point, the port on the transit node enters a preforwarding state in which it forwards EPSR packets over the control VLAN to the AT-9400 Switch. However, the transit node does not forward traffic over the data VLANs of the ring until it receives a “links up” message from the unit on the other side of the repaired break, in this case the AT-9400 Switch. Since EPSR snooping is not capable of generating EPSR messages, the transit node does not receive the anticipated signal, and so the data VLANs remain inactive. As a result, the AT-9400 Switch remains isolated from the ring until the other break is repaired and the master switch sends the EPSR Ring-Up-Flush-FDB message, which, in effect, initializes the ring.

## Guidelines

---

The guidelines to EPSR snooping are:

- ❑ The AT-9400 Switch can support up to sixteen control VLANs and so up to sixteen EPSR instances.
- ❑ The AT-9400 Switch cannot be the master node of a ring.
- ❑ EPSR snooping does not support the transit node unsolicited method of fault notification.
- ❑ The switch must be operating in the user-configure VLAN mode. EPSR snooping is not supported in the Multiple VLAN mode or the 802.1Q-compliant Multiple VLAN mode.
- ❑ The control VLAN must have exactly two ports. The only exception to this rule is if the ports of the control VLAN are part of a static port trunk. The ports, which must be tagged members of the VLAN, are used as the ring's ports of the EPSR instance.
- ❑ The ports of the control VLAN and the data VLANs of an EPSR instance cannot be running LACP, STP, or GARP.
- ❑ The control VLAN cannot be part of another EPSR instance as either a control or data VLAN.
- ❑ EPSR snooping is only compatible with the EPSR feature on Allied Telesis products.





## Section IV

# SNMPv3

---

The chapter in this section contains overview information on SNMPv3. The chapter is:

- Chapter 21, "SNMPv3" on page 219



# Chapter 21

## SNMPv3

---

This chapter provides a description of the AT-S63 implementation of the SNMPv3 protocol. The following sections are provided:

- ❑ “Supported Platforms” on page 220
- ❑ “Overview” on page 221
- ❑ “SNMPv3 Authentication Protocols” on page 222
- ❑ “SNMPv3 Privacy Protocol” on page 223
- ❑ “SNMPv3 MIB Views” on page 224
- ❑ “SNMPv3 Storage Types” on page 226
- ❑ “SNMPv3 Message Notification” on page 227
- ❑ “SNMPv3 Tables” on page 228
- ❑ “SNMPv3 Configuration Example” on page 232

## Supported Platforms

---

Refer to Table 66 and Table 67 for the AT-9400 Switches and the management interfaces that support SNMPv3.

Table 66. Support for SNMPv3

Switch	Supported
Layer 2+ Models	
AT-9408LC/SP	Yes
AT-9424T/GB	Yes
AT-9424T/SP	Yes
Basic Layer 3 Models	
AT-9424T	Yes
AT-9424T/POE	Yes
AT-9424Ts	Yes
AT-9424Ts/XP	Yes
AT-9448T/SP	Yes
AT-9448Ts/XP	Yes
AT-9400Ts Stack	Yes

Table 67. Management Interfaces for the SNMPv3

Switch or Stack	Standard Command Line	AlliedWare Plus Command Line	Menus	Web Browser
Stand-alone Switch	Yes		Yes	Yes
AT-9400Ts Stack	Yes			Yes

## Overview

---

The SNMPv3 protocol builds on the existing SNMPv1 and SNMPv2c protocol implementation which is described in Chapter 4, “SNMPv1 and SNMPv2c” on page 87. In SNMPv3, User-based Security Model (USM) authentication is implemented along with encryption, allowing you to configure a secure SNMP environment.

In addition, SNMP terminology changes in the SNMPv3 protocol. In the SNMPv1 and SNMPv2c protocols, the terms *agent* and *manager* are used. An agent is an SNMP user while a manager is an SNMP host. In the SNMPv3 protocol, agents and managers are called *entities*. In any SNMPv3 communication, there is an authoritative entity and a non-authoritative entity. The authoritative entity checks the authenticity of the non-authoritative entity. And, the non-authoritative entity checks the authenticity of the authoritative entity.

With the SNMPv3 protocol, you create users, determine the protocol used for message authentication as well as determine if data transmitted between two SNMP entities is encrypted. In addition, you can restrict user privileges by determining the user’s view of the Management Information Bases (MIB). In this way, you restrict which MIBs the user can display and modify. In addition, you can restrict the types of messages, or traps, the user can send. (A trap is a type of SNMP message.)

After you have created a user, you define SNMPv3 message notification. This consists of determining where messages are sent and what types of messages can be sent. This configuration is similar to the SNMPv1 and SNMPv2c configuration because you configure IP addresses of trap receivers, or hosts. In addition, with the SNMPv3 implementation you decide what types of messages are sent.

---

**Note**

For the SNMP RFCs supported by this release of the AT-S63 software, see “Remote SNMP Management” on page 44.

---

This section further describes the features of the SNMPv3 protocol. The following subsections are included:

- ❑ “SNMPv3 Authentication Protocols” on page 222
- ❑ “SNMPv3 Privacy Protocol” on page 223
- ❑ “SNMPv3 MIB Views” on page 224
- ❑ “SNMPv3 Storage Types” on page 226
- ❑ “SNMPv3 Message Notification” on page 227
- ❑ “SNMPv3 Tables” on page 228
- ❑ “SNMPv3 Configuration Example” on page 232

## SNMPv3 Authentication Protocols

---

The SNMPv3 protocol supports two authentication protocols—HMAC-MD5-96 (MD5) and HMAC-SHA-96 (SHA). Both MD5 and SHA use an algorithm to generate a message digest. Each authentication protocol authenticates a user by checking the message digest. In addition, both protocols use keys to perform authentication. The keys for both protocols are generated locally using the Engine ID, a unique identifier that is assigned to the switch automatically, and the user password. You modify a key only by modifying the user password.

In addition, you have the option of assigning no user authentication. In this case, no authentication is performed for this user. You may want to make this configuration for someone with super-user capabilities.

---

**Note**

The keys generated by the MD5 and SHA protocols are specific to the SNMPv3 protocol. They have no relation to the SSL and SSH keys for encryption.

---

## SNMPv3 Privacy Protocol

---

After you have configured an authentication protocol, you have the option of assigning a privacy protocol if you have the encrypted version of the AT-S63 software. In SNMPv3 protocol terminology, privacy is equivalent to encryption. Currently, the DES protocol is the only encryption protocol supported. The DES privacy protocol requires the authentication protocol to be configured as either MD5 or SHA.

If you assign a DES privacy protocol to a user, then you are also required to assign a privacy password. If you choose to not assign a privacy value, then SNMPv3 messages are sent in plain text format.

## SNMPv3 MIB Views

The SNMPv3 protocol allows you to configure MIB views for users and groups. The MIB tree is defined by RFC 1155 (Structure of Management Information). See Figure 19.

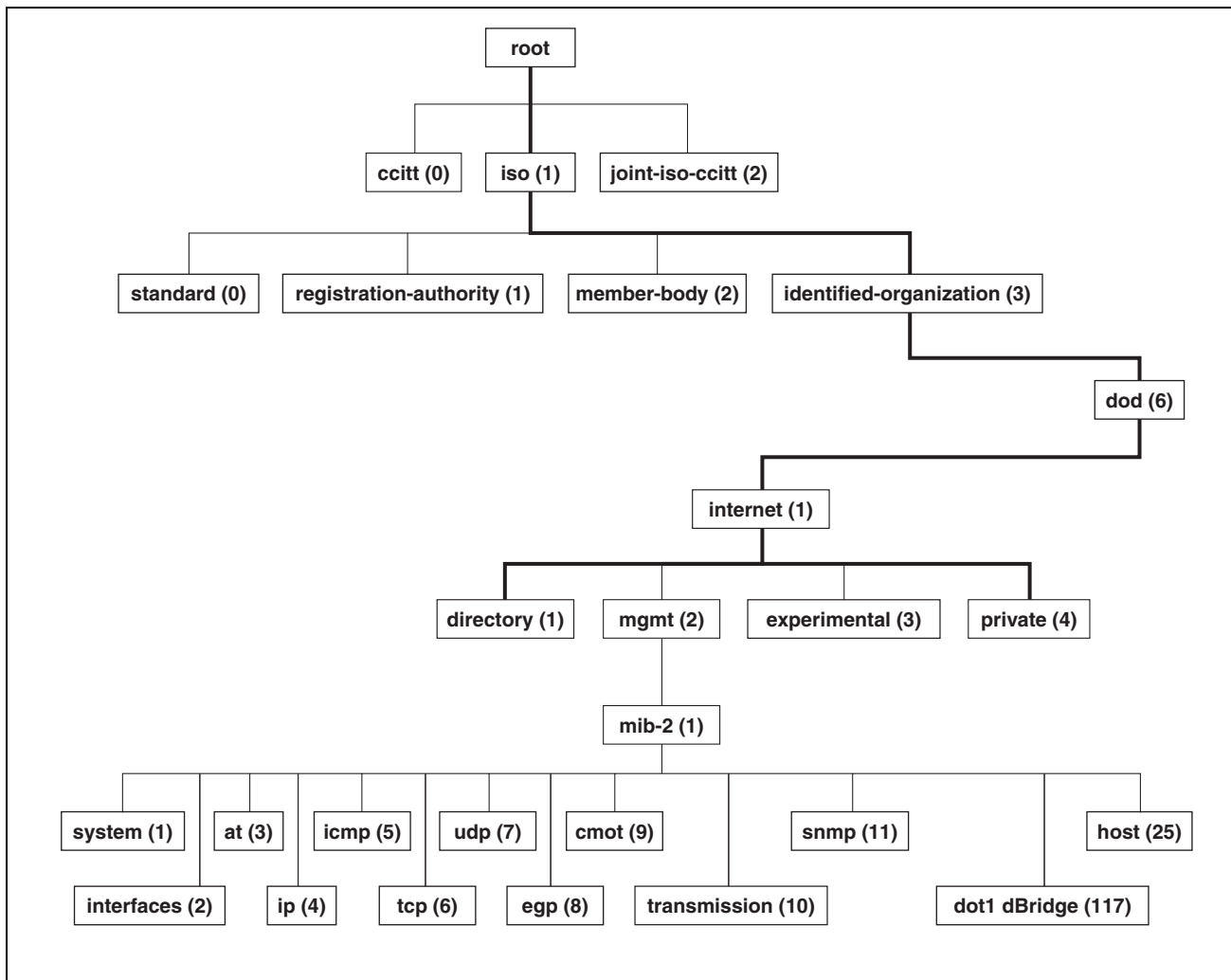

Figure 19. MIB Tree

The AT-S63 software supports the MIB tree, starting with the Internet MIBs, as defined by 1.3.6.1. There are two ways to specify a MIB view. You can enter the OID number of the MIB view or its equivalent text name. For example, to specify MIBs in the Internet view, you can enter the OID format “1.3.6.1” or the text name “internet.”

In addition, you can define a MIB view that the user can access or a MIB view that the user cannot access. When you want to permit a user to access a MIB view, you include a particular view. When you want to deny a user access to a MIB view, you exclude a particular view.



After you specify a MIB subtree view you have the option of further restricting a view by defining a subtree mask. The relationship between a MIB subtree view and a subtree mask is analogous to the relationship between an IP address and a subnet mask. The switch uses the subnet mask to determine which portion of an IP address represents the network address and which portion represents the node address. In a similar way, the subtree mask further refines the subtree view and enables you to restrict a MIB view to a specific row of the OID MIB table. You need a thorough understanding of the OID MIB table to define a subtree mask.

## SNMPv3 Storage Types

---

Each SNMPv3 table entry has its own storage type. You can choose between nonvolatile storage which allows you to save the table entry or volatile storage which does not allow you to save an entry. If you select the volatile storage type, when you power off the switch your SNMPv3 configuration is lost and cannot be recovered.

At each SNMPv3 menu, you are prompted to configure a storage type. You do not have to configure the same storage type value for each table entry.

## SNMPv3 Message Notification

---

When you generate an SNMPv3 message from the switch, there are three basic pieces of information included in the message:

- ❑ The type of message
- ❑ The destination of the message
- ❑ SNMP security information

To configure the type of message, you need to define if you are sending a Trap or Inform message. Basically, the switch expects a response to an Inform message and the switch does not expect a response to a Trap message. These two message types are defined in the SNMPv3 (RFC 2571-6).

To determine the destination of the message, you configure the IP address of the host. This configuration is similar to the SNMPv1 and SNMPv2c configuration.

The SNMP security information consists of information about the following:

- ❑ User
- ❑ View of the MIB Tree
- ❑ Security Level
- ❑ Security Model
- ❑ Authentication Level
- ❑ Privacy Protocol
- ❑ Group

To configure the SNMP security information, you associate a user and its related information—View, Security Level, Security Model, Authentication Level, Privacy Protocol and Group—with the type of message and the host IP address.

## SNMPv3 Tables

The SNMPv3 configuration is neatly divided into configuring SNMPv3 user information and configuring the message notification. You must configure all seven tables to successfully configure the SNMPv3 protocol. You use the following tables for user configuration:

- ❑ Configure SNMPv3 User Table
- ❑ Configure SNMPv3 View Table
- ❑ Configure SNMPv3 Access Table
- ❑ Configure SNMPv3 SecurityToGroup Table

First, you create a user in the Configure SNMPv3 User Table. Then you define the MIB view this user has access to in the Configure SNMPv3 View Table. To configure a security group and associate a MIB view to a security group, you configure the Configure SNMPv3 Access Table. Finally, configure the Configure SNMPv3 SecurityToGroup menu to associate a user to a security group. See Figure 20 for an illustration of how the user configuration tables are linked.

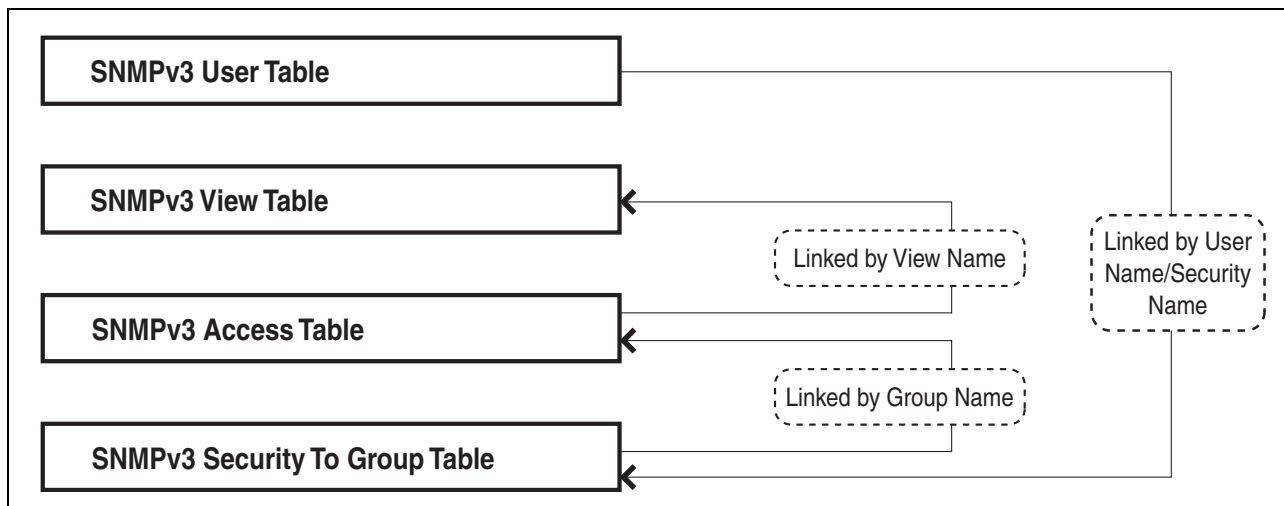

Figure 20. SNMPv3 User Configuration Process

In general, you focus on configuring security groups and then add and delete users from the groups as needed. For example, you may want to have two groups—one for manager privileges and a second one for operator privileges. See Appendix B, “SNMPv3” on page 219 for an example of manager and operator configurations.

After you configure an SNMPv3 user, you need to configure SNMPv3 message notification. This configuration is accomplished with the following tables:

- ❑ Configure SNMPv3 Notify Table
- ❑ Configure SNMPv3 Target Address Table
- ❑ Configure SNMPv3 Target Parameters Table

You start the message notification configuration by defining the type of message you want to send with the SNMPv3 Notify Table. Then you define a IP address that is used for notification in the Configure SNMPv3 Target Address Table. This is the IP address of the SNMPv3 host. Finally, you associate the trap information with a user by configuring the Configure SNMPv3 Target Parameters Table.

See Figure 21 for an illustration of how the message notification tables are linked.

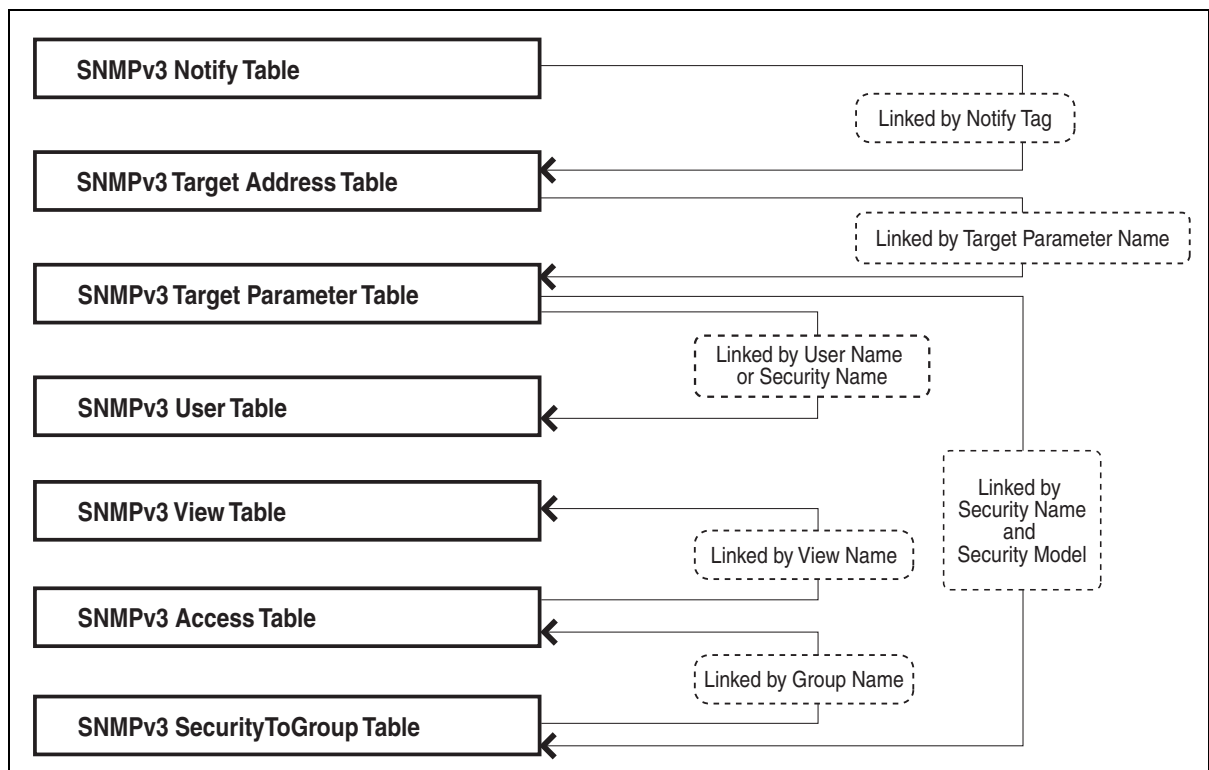

Figure 21. SNMPv3 Message Notification Process

For a more detailed description of the SNMPv3 Tables, see the following subsections:

- ❑ “SNMPv3 User Table” on page 230
- ❑ “SNMPv3 View Table” on page 230
- ❑ “SNMPv3 SecurityToGroup Table” on page 230
- ❑ “SNMPv3 Notify Table” on page 231
- ❑ “SNMPv3 Target Address Table” on page 231

- ❑ “SNMPv3 Target Parameters Table” on page 231
- ❑ “SNMPv3 Community Table” on page 231

### **SNMPv3 User Table**

The Configure SNMPv3 User Table menu allows you to create an SNMPv3 user and provides the options of configuring authentication and privacy protocols. With the SNMPv3 protocol, users are authenticated when they send and receive messages. In addition, you can configure a privacy protocol and password so messages a user sends and receives are encrypted. The DES privacy algorithm uses the privacy password and the Engine ID to generate a key that is used for encryption. Lastly, you can configure a storage type for this table entry which allows you to save this user and its related configuration to flash memory.

### **SNMPv3 View Table**

The Configure SNMPv3 View Table menu allows you to create a view of the MIB OID Table. First, you configure a view of a subtree. Then you have the option of configuring a Subtree Mask that further refines the subtree view. For example, you can use a Subtree Mask to restrict a user’s view to one row of the MIB OID Table. In addition, you can chose to include or exclude a view. As a result, you can let a user see a particular view or prevent a user from seeing a particular view. Lastly, you can configure a storage type for this table entry which allows you to save this view to flash memory.

### **SNMPv3 Access Table**

The Configure SNMPv3 Access Table menu allows you to configure a security group. After you create a security group, you assign a set of users with the same access privileges to this group using the SNMPv3 SecurityToGroup Table. Consider the types of groups you want to create and the types of access privileges each group will have. In this way, you can more easily keep track of your users as belonging to one or two groups.

For each group, you can assign read, write, and notify views of the MIB table. The views you assign here have been previously defined in the Configure SNMPv3 View Table menu. For example, the Read View allows group members to view the specified portion of the OID MIB table. The Write View allows group members to write to, or modify, the MIBs in the specified MIB view. The Notify View allows group members to send trap messages defined by the MIB view. Lastly, you can configure a storage type for this table entry which allows you to save this view to flash memory.

### **SNMPv3 SecurityToGroup Table**

The Configure SNMPv3 SecurityToGroup Table menu allows you to associate a User Name with a security group called a Group Name. The User Name is previously configured with the Configure SNMPv3 User Table menu. The security group is previously configured with the Configure SNMPv3 Access Table menu. Lastly, you can configure a storage type for this table entry which allows you to save the entry to flash memory.

**SNMPv3 Notify  
Table**

The Configure SNMPv3 Notify Table menu allows you to define the type of message that is sent from the switch to the SNMP host. In addition, you have the option of defining the message type as either an Inform or a Trap message. The difference between these two types of messages is that when a switch sends an Inform message, the switch expects a response from the host. In comparison, the switch does not expect the host to respond to Trap messages.

In addition, you define a Notify Tag that links an SNMPv3 Notify Table entry to the host IP address defined in the Configure SNMPv3 Target Address Table menu. Lastly, you can configure a storage type for this table entry which allows you to save the entry to flash memory.

**SNMPv3 Target  
Address Table**

The Configure SNMPv3 Target Address Table menu allows you to configure the IP address of the host. Also, in an SNMPv3 Target Address Table entry, you configure the values of the Tag List parameter with the previously defined Notify Tag parameter values. The Notify Tag parameter is configured in the Configure SNMPv3 Notify Table. In this way, the Notify and Target Address tables are linked. Lastly, you can configure a storage type for this table entry which allows you to save the entry to flash memory.

**SNMPv3 Target  
Parameters Table**

The Configure SNMPv3 Target Parameters Table menu allows you to define which user can send messages to the host IP address defined in the Configure SNMPv3 Target Address Table. The user and its associated information is previously configured in the Configure SNMPv3 User Table, SNMPv3 View Table, SNMPv3 Access Table, and SNMPv3 SecurityToGroup Table. Lastly, you can configure a storage type for this table entry which allows you to save the entry to flash memory.

**SNMPv3  
Community  
Table**

The Configure SNMPv3 Community Table menu allows you to configure SNMPv1 and SNMPv2c communities. If you are going to use the SNMPv3 Tables to configure SNMPv1 and SNMPv2c communities, start with the SNMPv3 Community Table.

## SNMPv3 Configuration Example

---

You may want to have two classes of SNMPv3 users—Managers and Operators. In this scenario, you would configure one group, called Managers, with full access privileges. Then you would configure a second group, called Operators, with monitoring privileges only. For a detailed example of this configuration, see Appendix B, “SNMPv3 Configuration Examples” on page 499.



## Section V

# Spanning Tree Protocols

---

The section has the following chapters:

- ❑ Chapter 22, “Spanning Tree and Rapid Spanning Tree Protocols” on page 235
- ❑ Chapter 23, “Multiple Spanning Tree Protocol” on page 247



## Chapter 22

# Spanning Tree and Rapid Spanning Tree Protocols

---

This chapter provides background information on the Spanning Tree Protocol (STP) and Rapid Spanning Tree Protocol (RSTP). The sections in this chapter include:

- ❑ “Supported Platforms” on page 236
- ❑ “Overview” on page 237
- ❑ “Bridge Priority and the Root Bridge” on page 238
- ❑ “Forwarding Delay and Topology Changes” on page 242
- ❑ “Mixed STP and RSTP Networks” on page 245
- ❑ “Spanning Tree and VLANs” on page 246

---

### **Note**

For detailed information on the Spanning Tree Protocol, refer to IEEE Std 802.1D. For detailed information on the Rapid Spanning Tree Protocol, refer to IEEE Std 802.1w.

---

## Supported Platforms

---

Refer to Table 68 and Table 69 for the AT-9400 Switches and the management interfaces that support the Spanning Tree and Rapid Spanning Tree Protocols.

Table 68. Support for the Spanning Tree and Rapid Spanning Tree Protocols

Switch	Supported
Layer 2+ Models	
AT-9408LC/SP	Yes
AT-9424T/GB	Yes
AT-9424T/SP	Yes
Basic Layer 3 Models	
AT-9424T	Yes
AT-9424T/POE	Yes
AT-9424Ts	Yes
AT-9424Ts/XP	Yes
AT-9448T/SP	Yes
AT-9448Ts/XP	Yes
AT-9400Ts Stack	Yes

Table 69. Management Interfaces for the Spanning Tree and Rapid Spanning Tree Protocols

Switch or Stack	Standard Command Line	AlliedWare Plus Command Line	Menus	Web Browser
Stand-alone Switch	Yes	Yes	Yes	Yes
AT-9400Ts Stack	Yes	Yes		Yes

## Overview

---

The performance of a Ethernet network can be negatively impacted by the formation of a data loop in the network topology. A data loop exists when two or more nodes on a network can transmit data to each other over more than one data path. The problem that data loops pose is that data packets can become caught in repeating cycles, referred to as broadcast storms, that needlessly consume network bandwidth and can significantly reduce network performance.

STP and RSTP prevent data loops from forming by ensuring that only one path exists between the end nodes in your network. Where multiple paths exist, these protocols place the extra paths in a standby or blocking mode, leaving only one main active path.

STP and RSTP can also activate a redundant path if the main path goes down. So not only do these protocols guard against multiple links between segments and the risk of broadcast storms, but they can also maintain network connectivity by activating a backup redundant path in case a main link fails.

Where the two protocols differ is in the time each takes to complete the process referred to as *convergence*. When a change is made to the network topology, such as the addition of a new bridge, a spanning tree protocol must determine whether there are redundant paths that must be blocked to prevent data loops, or activated to maintain communications between the various network segments. This is the process of convergence.

With STP, convergence can take up to a minute to complete in a large network. This can result in the loss of communication between various parts of the network during the convergence process, and the subsequent lost of data packets.

RSTP is much faster. It can complete a convergence in seconds, and so greatly diminish the possible impact the process can have on your network.

Only one spanning tree can be active on the switch at a time. The default is RSTP.

The STP implementation on the AT-S63 Management Software complies with the IEEE 802.1d standard. The RSTP implementation complies with the IEEE 802.1w standard. The following subsections provide a basic overview on how STP and RSTP operate and define the different parameters that you can adjust.

## Bridge Priority and the Root Bridge

---

The first task that bridges perform when a spanning tree protocol is activated on a network is the selection of a *root bridge*. A root bridge distributes network topology information to the other network bridges and is used by the other bridges to determine if there are redundant paths in the network.

A root bridge is selected by the *bridge priority* number, also referred to as the bridge identifier, and sometimes the bridge's MAC address. The bridge with the lowest bridge priority number in the network is selected as the root bridge. If two or more bridges have the same bridge priority number, of those bridges the one with the lowest MAC address is designated as the root bridge.

You can change the bridge priority number in the AT-S63 Management Software. You can designate which switch on your network you want as the root bridge by giving it the lowest bridge priority number. You might also consider which bridge should function as the backup root bridge in the event you need to take the primary root bridge offline, and assign that bridge the second lowest bridge identifier number.

The bridge priority has a range 0 to 61440 in increments of 4096. To make this easier for you, the AT-S63 Management Software divides the range into increments. You specify the increment that represents the desired bridge priority value. The range is divided into sixteen increments, as shown in Table 70.

Table 70. Bridge Priority Value Increments

Increment	Bridge Priority	Increment	Bridge Priority
0	0	8	32768
1	4096	9	36864
2	8192	10	40960
3	12288	11	45056
4	16384	12	49152
5	20480	13	53248
6	24576	14	57344
7	28672	15	61440

## Path Costs and Port Costs

After the root bridge has been selected, the bridges determine if the network contains redundant paths and, if one is found, select a preferred path while placing the redundant paths in a backup or blocking state.

Where there is only one path between a bridge and the root bridge, the bridge is referred to as the *designated bridge* and the port through which the bridge is communicating with the root bridge is referred to as the *root port*.

If redundant paths exist, the bridges that are a part of the paths must determine which path will be the primary, active path, and which path(s) will be placed in the standby, blocking mode. This is accomplished by an determination of *path costs*. The path offering the lowest cost to the root bridge becomes the primary path and all other redundant paths are placed into blocking state.

Path cost is determined by evaluating *port costs*. Every port on a bridge participating in STP has a cost associated with it. The cost of a port on a bridge is typically based on port speed. The faster the port, the lower the port cost. The exception to this is the ports on the root bridge, where all ports have a port cost of 0.

Path cost is simply the sum of the port costs between a bridge and the root bridge.

The port cost of a port on the AT-9400 Switch is adjustable through the AT-S63 Management Software. For STP, the range is 0 to 65,535. For RSTP, the range is 0 to 20,000,000.

Port cost also has an Auto-Detect feature. This feature allows spanning tree to automatically set the port cost according to the speed of the port, assigning a lower value for higher speeds. Auto-Detect is the default setting. Table 73 lists the STP port costs with Auto-Detect.

Table 71. STP Auto-Detect Port Costs

Port Speed	Port Cost
10 Mbps	100
100 Mbps	10
1000 Mbps	4

Table 72 lists the STP port costs with Auto-Detect when a port is part of a port trunk.

Table 72. STP Auto-Detect Port Trunk Costs

Port Speed	Port Cost
10 Mbps	4
100 Mbps	4
1000 Mbps	2

Table 73 lists the RSTP port costs with Auto-Detect.

Table 73. RSTP Auto-Detect Port Costs

Port Speed	Port Cost
10 Mbps	2,000,000
100 Mbps	200,000
1000 Mbps	20,000

Table 74 lists the RSTP port costs with Auto-Detect when the port is part of a port trunk.

Table 74. RSTP Auto-Detect Port Trunk Costs

Port Speed	Port Cost
10 Mbps	20,000
100 Mbps	20,000
1000 Mbps	2,000

You can override Auto-Detect and set the port cost manually.

## Port Priority

If two paths have the same port cost, the bridges must select a preferred path. In some instances this can involve the use of the *port priority* parameter. This parameter is used as a tie breaker when two paths have the same cost.

The range for port priority is 0 to 240. As with bridge priority, this range is broken into increments, in this case multiples of 16. To select a port priority for a port, you enter the increment of the desired value. Table 75 lists the values and increments. The default value is 128, which is increment 8.



Table 75. Port Priority Value Increments

<b>Increment</b>	<b>Bridge Priority</b>	<b>Increment</b>	<b>Bridge Priority</b>
0	0	8	128
1	16	9	144
2	32	10	160
3	48	11	176
4	64	12	192
5	80	13	208
6	96	14	224
7	112	15	240

## Forwarding Delay and Topology Changes

---

If there is a change in the network topology due to a failure, removal, or addition of any active components, the active topology also changes. This may trigger a change in the state of some blocked ports. However, a change in a port state is not activated immediately.

It might take time for the root bridge to notify all bridges that a topology change has occurred, especially if it is a large network. If a topology change is made before all bridges have been notified, a temporary data loop could occur, and that could adversely impact network performance.

To forestall the formation of temporary data loops during topology changes, a port designated to change from blocking to forwarding passes through two additional states—listening and learning—before it begins to forward frames. The amount of time a port spends in these states is set by the forwarding *delay* value. This value states the amount of time that a port spends in the listening and learning states prior to changing to the forwarding state.

The forwarding delay value is adjustable in the AT-S63 Management Software. The appropriate value for this parameter depends on a number of variables; the size of your network is a primary factor. For large networks, you should specify a value large enough to allow the root bridge sufficient time to propagate a topology change throughout the entire network. For small networks, you should not specify a value so large that a topology change is unnecessarily delayed, which could result in the delay or loss of some data packets.

---

**Note**

The forwarding delay parameter applies only to ports on the switch that are operating STP-compatible mode.

---

### Hello Time and Bridge Protocol Data Units (BPDU)

The bridges that are part of a spanning tree domain communicate with each other using a bridge broadcast frame that contains a special section devoted to carrying STP or RSTP information. This portion of the frame is referred to as the bridge protocol data unit (BPDU). When a bridge is brought online, it issues a BPDU in order to determine whether a root bridge has already been selected on the network, and if not, whether it has the lowest bridge priority number of all the bridges and should therefore become the root bridge.

The root bridge periodically transmits a BPDU to determine whether there have been any changes to the network topology and to inform other bridges of topology changes. The frequency with which the root bridge sends out a BPDU is called the *hello time*. This is a value that you can set in the AT-S63 Management Software. The interval is measured in

seconds and the default is two seconds. Consequently, if the AT-9400 Switch is selected as the root bridge of a spanning tree domain, it transmits a BPDU every two seconds.

## Point-to-Point and Edge Ports

### Note

This section applies only to RSTP.

Part of the task of configuring RSTP is defining the port types on the bridge. This relates to the device(s) connected to the port. With the port types defined, RSTP can reconfigure a network much quicker than STP when a change in network topology is detected.

There are two possible selections:

- Point-to-point port
- Edge port

If a bridge port is operating in full-duplex mode, than the port is functioning as a point-to-point port. Figure 22 illustrates two AT-9400 Switches that are connected with one data link. With the link operating in full-duplex, the ports are point-to-point ports.

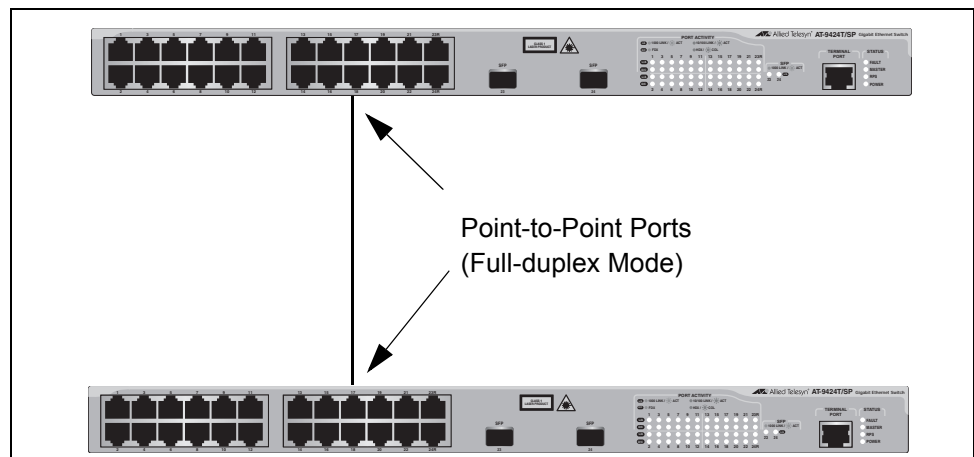

Figure 22. Point-to-Point Ports

If a port is operating in half-duplex mode and is not connected to any further bridges participating in STP or RSTP, then the port is an edge port. Figure 23 illustrates an edge port on an AT-9400 Switch. The port is connected to an Ethernet hub, which in turn is connected to a series of Ethernet workstations. This is an edge port because it is connected to a device operating at half-duplex mode and there are no participating STP or RSTP devices connected to it.

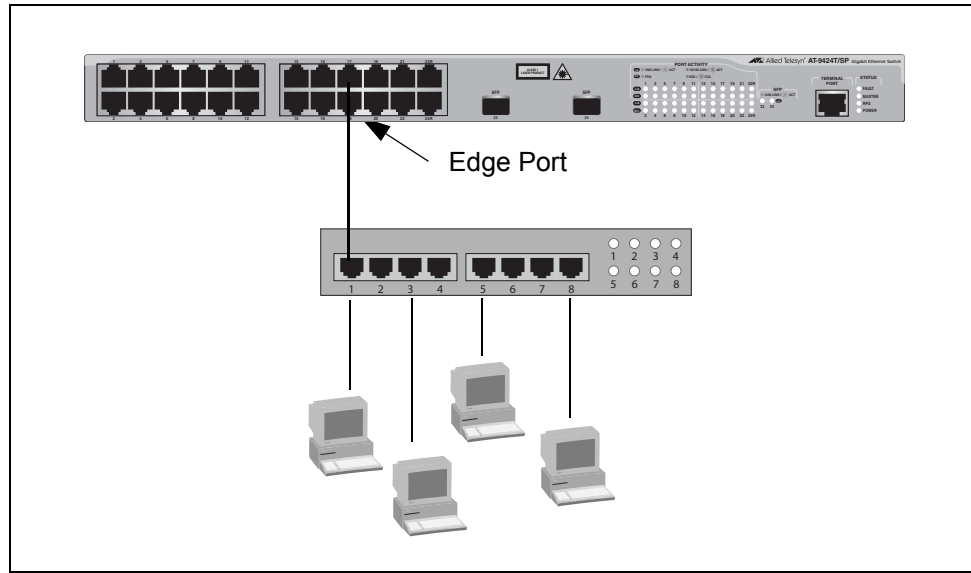

Figure 23. Edge Port

A port can be both a point-to-point and an edge port at the same time. It operates in full-duplex and has no STP or RSTP devices connected to it. Figure 24 illustrates a port functioning as both a point-to-point and edge port.

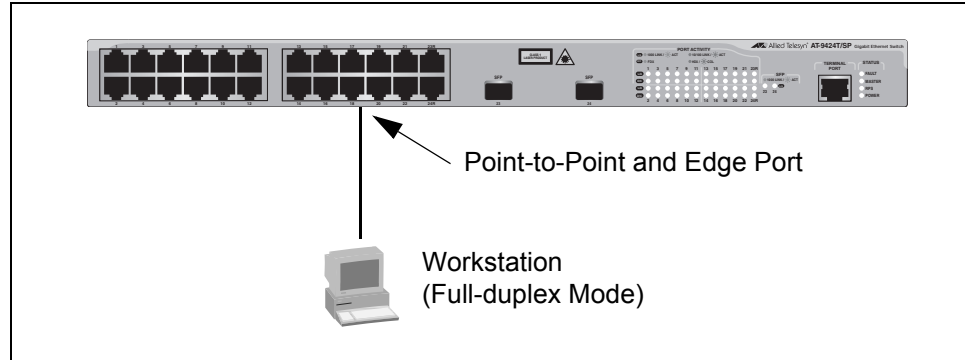

Figure 24. Point-to-Point and Edge Port

Determining whether a bridge port is point-to-point, edge, or both, can be a bit confusing. For that reason, do not change the default values for this RSTP feature unless you have a good grasp of the concept. In most cases, the default values work well.

## Mixed STP and RSTP Networks

---

RSTP IEEE 802.1w is fully compliant with STP IEEE 802.1d. Your network can consist of bridges running both protocols. STP and RSTP in the same network can operate together to create a single spanning tree domain.

If you decide to activate spanning tree on the switch, there is no reason not to activate RSTP on the AT-9400 Switch even when all other switches are running STP. The switch can combine its RSTP with the STP of the other switches. The switch monitors the traffic on each port for BPDU packets. Ports that receive RSTP BPDU packets operates in RSTP mode while ports receiving STP BPDU packets operate in STP mode.

## Spanning Tree and VLANs

The spanning tree implementation in the AT-S63 Management Software is a single-instance spanning tree. The switch supports just one spanning tree. You cannot define multiple spanning trees.

The single spanning tree encompasses all ports on the switch. If the ports are divided into different VLANs, the spanning tree crosses the VLAN boundaries. This point can pose a problem in networks containing multiple VLANs that span different switches and are connected with untagged ports. In this situation, STP blocks a data link because it detects a data loop. This can cause fragmentation of your VLANs.

This issue is illustrated in Figure 25. Two VLANs, Sales and Production, span two AT-9400 Switches. Two links consisting of untagged ports connect the separate parts of each VLAN. If STP or RSTP is activated on the switches, one of the links is disabled. In the example, the port on the top switch that links the two parts of the Production VLAN is changed to the block state. This leaves the two parts of the Production VLAN unable to communicate with each other.

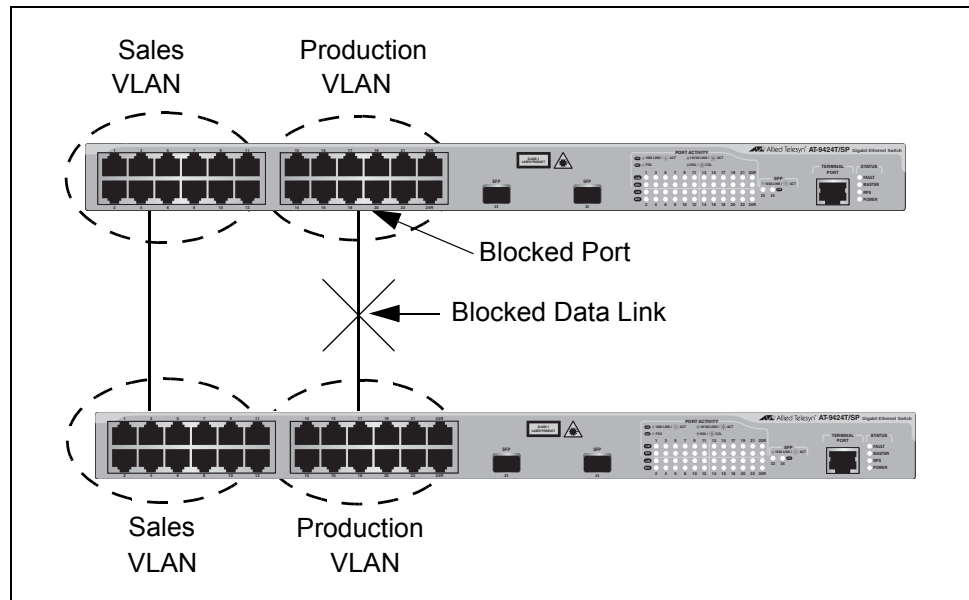

Figure 25. VLAN Fragmentation

You can avoid this problem by not activating spanning tree or by connecting VLANs using tagged instead of untagged ports. (For information on tagged and untagged ports, refer to Chapter 24, “Port-based and Tagged VLANs” on page 269.)

## Chapter 23

# Multiple Spanning Tree Protocol

---

This chapter provides background information on the Multiple Spanning Tree Protocol (MSTP). The sections in this chapter include:

- ❑ “Supported Platforms” on page 248
- ❑ “Overview” on page 249
- ❑ “Multiple Spanning Tree Instance (MSTI)” on page 250
- ❑ “MSTI Guidelines” on page 254
- ❑ “VLAN and MSTI Associations” on page 255
- ❑ “Ports in Multiple MSTIs” on page 256
- ❑ “Multiple Spanning Tree Regions” on page 257
- ❑ “Summary of Guidelines” on page 261
- ❑ “Associating VLANs to MSTIs” on page 263
- ❑ “Connecting VLANs Across Different Regions” on page 265

## Supported Platforms

---

Refer to Table 76 and Table 77 for the AT-9400 Switches and the management interfaces that support the Multiple Spanning Tree Protocol.

Table 76. Support for the Multiple Spanning Tree Protocol

Switch	Supported
Layer 2+ Models	
AT-9408LC/SP	Yes
AT-9424T/GB	Yes
AT-9424T/SP	Yes
Basic Layer 3 Models	
AT-9424T	Yes
AT-9424T/POE	Yes
AT-9424Ts	Yes
AT-9424Ts/XP	Yes
AT-9448T/SP	Yes
AT-9448Ts/XP	Yes
AT-9400Ts Stack	

Table 77. Management Interfaces for the Multiple Spanning Tree Protocol

Switch or Stack	Standard Command Line	AlliedWare Plus Command Line	Menus	Web Browser
Stand-alone Switch	Yes	Yes	Yes	Yes
AT-9400Ts Stack				



## Overview

---

As mentioned in Chapter 22, "Spanning Tree and Rapid Spanning Tree Protocols" on page 235, STP and RSTP are referred to as single-instance spanning trees that search for physical loops across all VLANs in a bridged network. When loops are detected, the protocols stop the loops by placing one or more bridge ports in a blocking state.

As explained in "Spanning Tree and VLANs" on page 246, STP and RSTP can result in VLAN fragmentation where VLANs that span multiple bridges are connected together with untagged ports. The untagged ports creating the links can represent a physical loop in the network, which are blocked by spanning tree. This can result in a loss of communication between different parts of the same VLAN.

One way to resolve this, other than by not activating spanning tree on your network, is to link the switches using tagged ports, which can handle traffic from multiple VLANs simultaneously. The drawback to this approach is that the link formed by the tagged ports can create a bottleneck to your Ethernet traffic, resulting in reduced network performance.

Another approach is to use the Multiple Spanning Tree Protocol (MSTP). This spanning tree shares many of the same characteristics as RSTP in that it features rapid convergence and has many of the same parameters. But the main difference is that while RSTP, just like STP, supports only a single-instance spanning tree, MSTP supports multiple spanning trees within a network.

The following sections describe some of the terms and concepts related to MSTP. If you are not familiar with spanning tree or RSTP, you should first review "Overview" on page 237.

---

**Note**

Do not activate MSTP on the AT-9400 Switch without first familiarizing yourself with the following concepts and guidelines. Unlike STP and RSTP, you cannot activate this spanning tree protocol on a switch without first configuring the protocol parameters.

---

---

**Note**

The AT-S63 MSTP implementation complies fully with the new IEEE 802.1s standard and should be interoperable with any other vendor's fully compliant 802.1s implementation.

---

## Multiple Spanning Tree Instance (MSTI)

---

The individual spanning trees in MSTP are referred to as Multiple Spanning Tree Instances (MSTIs). A MSTI can span any number of AT-9400 Switches. The switch can support up to 16 MSTIs at a time.

To create a MSTI, you first assign it a number, referred to as the MSTI ID. The range is 1 to 15. (The switch is shipped with a default MSTI with an MSTI ID of 0. This default spanning tree instance is discussed later in “Common and Internal Spanning Tree (CIST)” on page 260.)

After you have selected an MSTI ID, you need to define the scope of the MSTI by assigning one or more VLANs to it. An instance can contain any number of VLANs, but a VLAN can belong to only one MSTI at a time.

Following are several examples. Figure 26 illustrates two AT-9400 Switches, each containing the two VLANs Sales and Production. The two parts of each VLAN are connected with a direct link using untagged ports on both switches. If the switches were running STP or RSTP, one of the links would be blocked because the links constitute a physical loop. Which link would be blocked depends on the STP or RSTP bridge settings. In Figure 26, the link between the two parts of the Production VLAN is blocked, resulting in a loss of communications between the two parts of the Production VLAN.

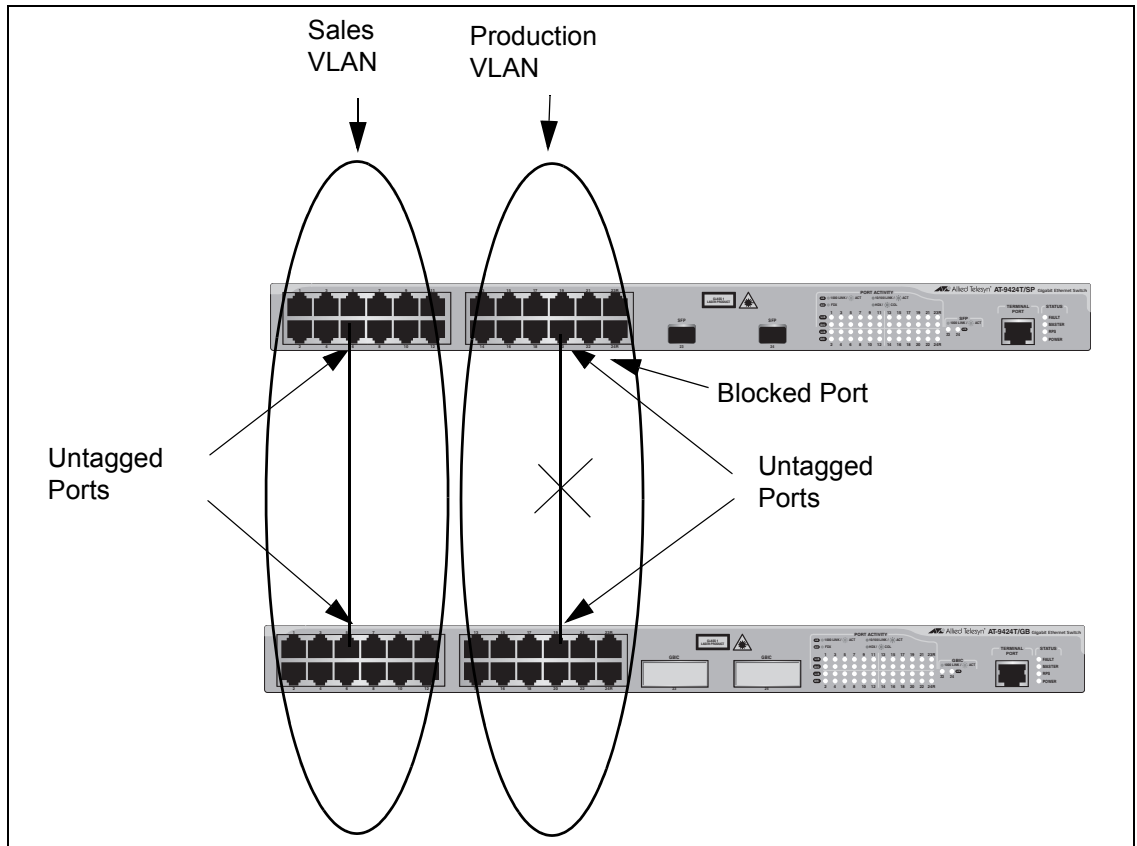

Figure 26. VLAN Fragmentation with STP or RSTP

Figure 27 illustrates the same two AT-9400 Switches and the same two virtual LANs. But in this example, the two switches are running MSTP and the two VLANs have been assigned different spanning tree instances. Now that they reside in different MSTIs, both links remain active, enabling the VLANs to forward traffic over their respective direct link.

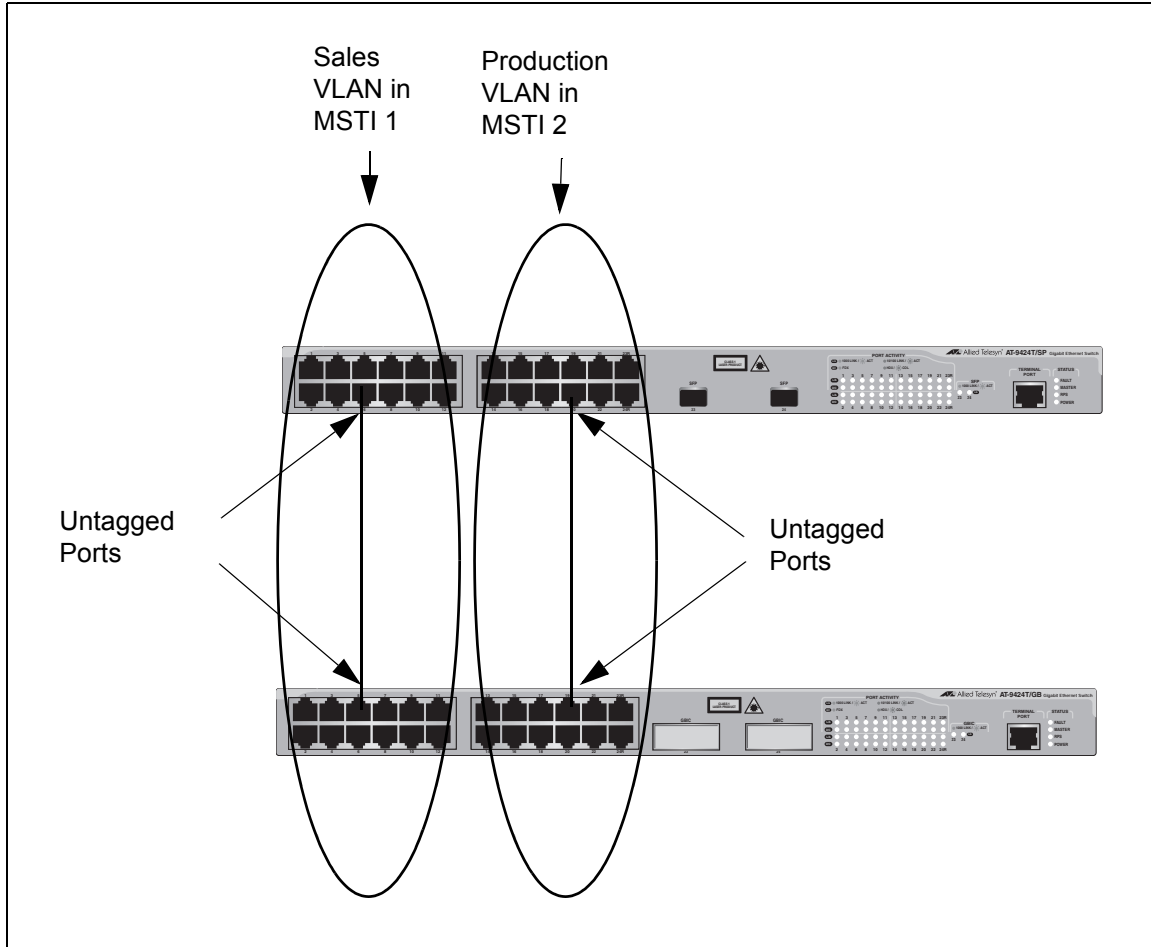

Figure 27. MSTP Example of Two Spanning Tree Instances

A MSTI can contain more than one VLAN. This is illustrated in Figure 28 where there are two AT-9400 Switches with four VLANs. There are two MSTIs, each containing two VLANs. MSTI 1 contains the Sales and Presales VLANs and MSTI 2 contains the Design and Engineering VLANs.

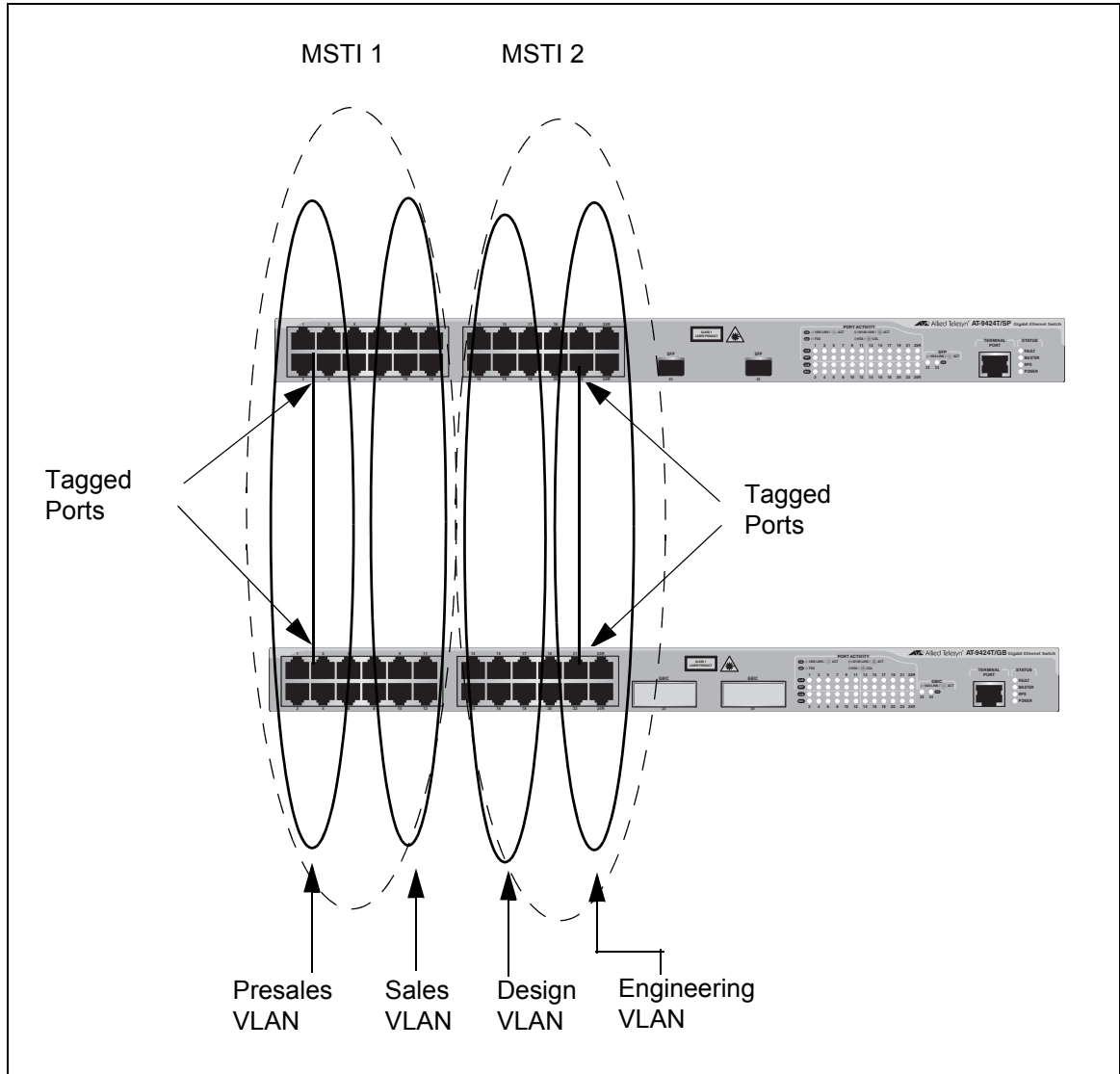

Figure 28. Multiple VLANs in a MSTI

In this example, because an MSTI contains more than one VLAN, the links between the VLAN parts is made with tagged, not untagged, ports so that they can carry traffic from more than one virtual LAN. Referring again to Figure 28, the tagged link in MSTI 1 is carrying traffic for both the Presales and Sales VLANs while the tagged link in MSTI 2 is carrying traffic for the Design and Engineering VLANs.

## MSTI Guidelines

---

The following are several guidelines to keep in mind about MSTIs:

- ❑ The AT-9400 Switch can support up to 16 spanning tree instances, including the CIST.
- ❑ A MSTI can contain any number of VLANs.
- ❑ A VLAN can belong to only one MSTI at a time.
- ❑ A switch port can belong to more than one spanning tree instance at a time by being an untagged and tagged member of VLANs belonging to different MSTI's. This is possible because a port can be in different MSTP states for different MSTI's simultaneously. For example, a port can be in the MSTP blocking state for one MSTI and the forwarding state for another spanning tree instance. For further information, refer to "Ports in Multiple MSTIs," next.

## VLAN and MSTI Associations

---

Part of the task to configuring MSTP involves assigning VLANs to spanning tree instances. The mapping of VLANs to MSTIs is called *associations*. A VLAN, either port-based or tagged, can belong to only one instance at a time, but an instance can contain any number of VLANs.

## Ports in Multiple MSTIs

---

A port can be a member of more than one MSTI at a time if it is a tagged member of one or more VLANs assigned to different MSTI's. In this circumstance, a port might have to operate in different spanning tree states simultaneously, depending on the requirements of the MSTIs. For example, a port that belongs to two different VLANs in two different MSTIs might operate in the forwarding state in one MSTI and the blocking state in the other.

A port's MSTI parameter settings are divided into two groups. The first group is referred to as generic parameters. These are set just once on a port and apply to all the MSTI's where the port is a member. One of these parameters is the external path cost, which sets the operating cost of a port connected to a device outside its region. A port, even if it belongs to multiple MSTI's, can have only one external path cost. Another generic parameter designates a port as an edge port or a point-to-point port.

The second group of port parameters can be set differently for each MSTI in which a port is a member. One parameter, the internal path cost, specifies the operating cost of a port when it is connected to a bridge in the same MSTP region. The other parameter in this group sets the port priority, which acts as a tie breaker when two or more ports have equal costs to a regional root bridge.



## Multiple Spanning Tree Regions

---

Another important concept of MSTP is *regions*. A MSTP region is defined as a group of bridges that share exactly the same MSTI characteristics. Those characteristics are:

- Configuration name
- Revision number
- VLANs
- VLAN to MSTI ID associations

A *configuration name* is a name assigned to a region to identify it. You must assign each bridge in a region exactly the same name; even the same upper and lowercase lettering. Identifying the regions in your network is easier if you choose names that are characteristic of the functions of the nodes and bridges of the region. Examples are Sales Region and Engineering Region.

The *revision number* is an arbitrary number assigned to a region. This number can be used to keep track of the revision level of a region's configuration. For example, you might use this value to maintain the number of times you revise a particular MSTP region. It is not important that you maintain this number, only that each bridge in a region has the same number.

The bridges of a particular region must also have the same VLANs. The names of the VLANs and the VIDs must be same on all bridges of a region.

Finally, the VLANs in the bridges must be associated to the same MSTIs.

If any of the above information is different on two bridges, MSTP does consider the bridges as residing in different regions.

Figure 29 illustrates the concept of regions. It shows one MSTP region consisting of two AT-9400 Switches. Each switch in the region has the same configuration name and revision level. The switches also have the same five VLANs and the VLANs are associated with the same MSTIs.

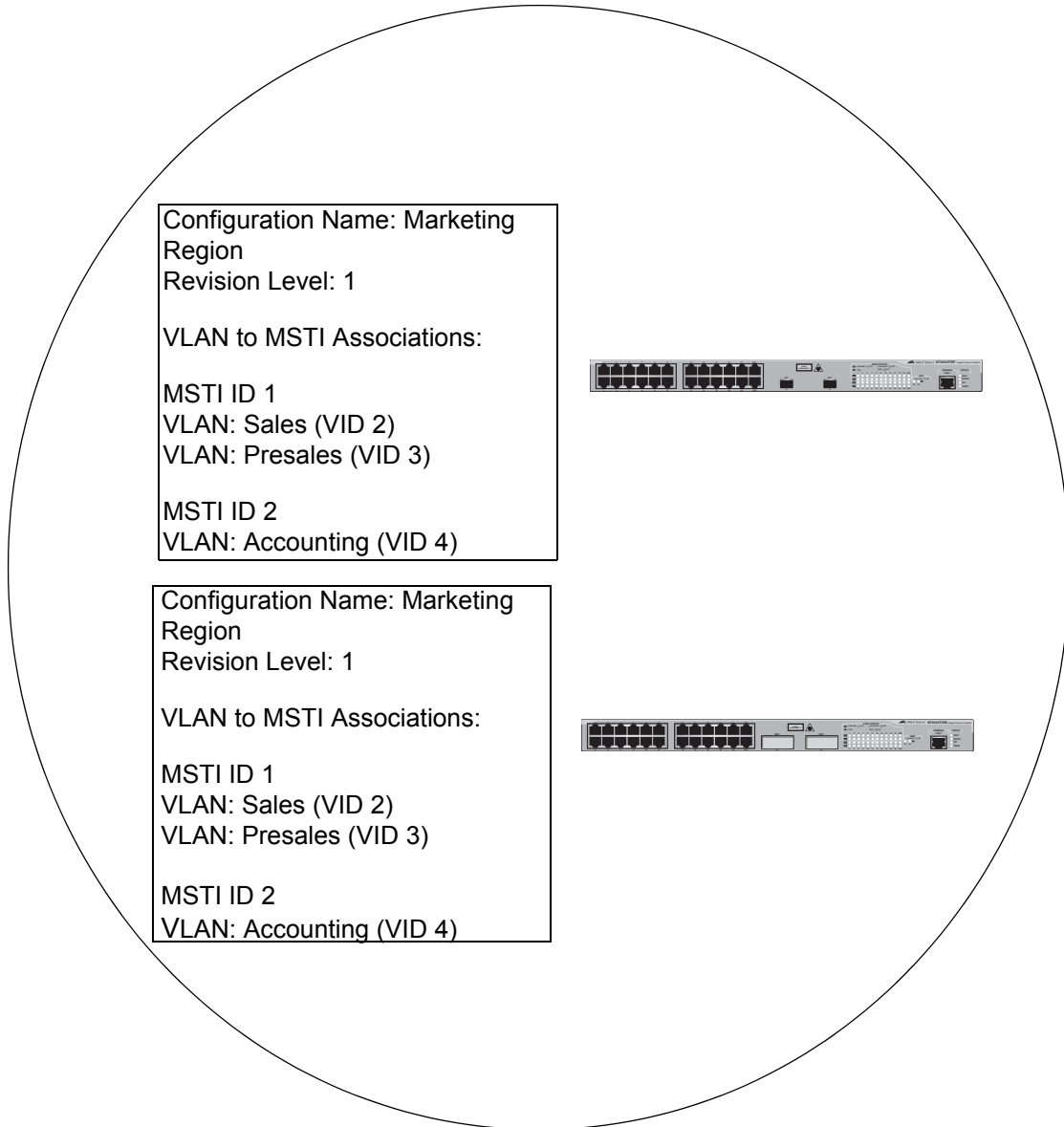

Figure 29. Multiple Spanning Tree Region

The AT-9400 Switch determines regional boundaries by examining the MSTP BPDUs received on the ports. A port that receives a MSTP BPDU from another bridge with regional information different from its own is considered to be a boundary port and the bridge connected to the port as belonging to another region.

The same is true for any ports connected to bridges running the single-instance spanning tree STP or RSTP. Those ports are also considered as part of another region.

Each MSTI functions as an independent spanning tree within a region. Consequently, each MSTI must have a root bridge to locate physical loops within the spanning tree instance. An MSTI's root bridge is called a *regional root*. The MSTIs within a region may share the same regional root or they can have different regional roots.

A regional root for an MSTI must be within the region where the MSTI is located. An MSTI cannot have a regional root that is outside its region.

A regional root is selected by a combination of the *MSTI priority* value and the bridge's MAC address. The MSTI priority is analogous to the RSTP bridge priority value. Where they differ is that while the RSTP bridge priority is used to determine the root bridge for an entire bridged network, MSTI priority is used only to determine the regional root for a particular MSTI.

The range for this parameter is the same as the RSTP bridge priority; from 0 to 61,440 in sixteen increments of 4,096. To set the parameter, you specify the increment that represents the desired MSTI priority value. Table 75 on page 241 lists the increments.

## Region Guidelines

Following are several points to remember about regions.

- A network can contain any number of regions and a region can contain any number of AT-9400 Switches.
- The AT-9400 Switch can belong to only one region at a time.
- A region can contain any number of VLANs.
- All of the bridges in a region must have the same configuration name, revision level, VLANs, and VLAN to MSTI associations.
- An MSTI cannot span multiple regions.
- Each MSTI must have a regional root for locating loops in the instance. MSTIs can share the same regional root or have different roots. A regional root is determined by the MSTI priority value and a bridge's MAC address.
- The regional root of a MSTI must be in the same region as the MSTI.

## **Common and Internal Spanning Tree (CIST)**

MSTP has a default spanning tree instance called the Common and Internal Spanning Tree (CIST). This instance has an MSTI ID of 0.

This instance has unique features and functions that make it different from the MSTIs that you create yourself. First, you cannot delete this instance and you cannot change its MSTI ID. Second, when you create a new port-based or tagged VLAN, it is by default associated with the CIST and is automatically given an MSTI ID of 0. The `Default_VLAN` is also associated by default with CIST.

Another critical difference is that when you assign a VLAN to another MSTI, it still partially remains a member of CIST. This is because CIST is used by MSTP to communicate with other MSTP regions and with any RSTP and STP single-instance spanning trees in the network. MSTP uses CIST to participate in the creation of a spanning tree between different regions and between regions and single-instance spanning tree, to form one spanning tree for the entire bridged network.

MSTP uses CIST to form the spanning tree of an entire bridged network because CIST can cross regional boundaries, while a MSTI cannot. If a port is a boundary port, that is, if it is connected to another region, that port automatically belongs solely to CIST, even if it was assigned to an MSTI, because only CIST is active outside of a region.

As mentioned earlier, every MSTI must have a root bridge, referred to as a regional root, in order to locate loops that might exist within the instance. CIST must also have a regional root. However, the CIST regional root communicates with the other MSTP regions and single-instance spanning trees in the bridged network.

The CIST regional root is set with the *CIST Priority* parameter. This parameter, which functions similar to the RSTP bridge priority value, selects the root bridge for the entire bridged network. If the AT-9400 Switch has the lowest CIST Priority value among all the spanning tree bridges, it functions as the root bridge for all the MSTP regions and STP and RSTP single-instance spanning trees in the network.

## **MSTP with STP and RSTP**

MSTP is fully compatible with STP and RSTP. If a port on the AT-9400 Switch running MSTP receives STP BPDUs, the port sends only STP BPDU packets. If a port receives RSTP BPDUs, the port sends MSTP BPDUs because RSTP can process MSTP BPDUs.

A port connected to a bridge running STP or RSTP is considered to be a boundary port of the MSTP region and the bridge as belonging to a different region.

An MSTP region can be considered as a virtual bridge. The implication is that other MSTP regions and STP and RSTP single-instance spanning trees cannot discern the topology or constitution of a MSTP region. The only bridge they are aware of is the regional root of the CIST instance.

## Summary of Guidelines

---

Careful planning is essential for the successful implementation of MSTP. This section reviews all the rules and guidelines mentioned in earlier sections, and contains a few new ones:

- ❑ The AT-9400 Switch can support up to 16 spanning tree instances, including the CIST, at a time.
- ❑ A MSTI can contain any number of VLANs.
- ❑ A VLAN can belong to only one MSTI at a time.
- ❑ An MSTI ID can be from 1 to 15.
- ❑ The CIST ID is 0. You cannot change this value.
- ❑ A switch port can belong to more than one spanning tree instance at a time. This allows you to assign a port as an untagged and tagged member of VLANs that belong to different MSTIs. What makes this possible is a port's ability to be in different MSTP states for different MSTIs simultaneously. For example, a port can be in the MSTP blocking state for one MSTI and the forwarding state for another spanning tree instance.
- ❑ A router or Layer 3 network device is required to forward traffic between VLANs.
- ❑ A network can contain any number of regions and a region can contain any number of AT-9400 Switches.
- ❑ The AT-9400 Switch can belong to only one region at a time.
- ❑ A region can contain any number of VLANs.
- ❑ All of the bridges in a region must have the same configuration name, revision level, VLANs, and VLAN to MSTI associations.
- ❑ An MSTI cannot span multiple regions.
- ❑ Each MSTI must have a regional root for locating loops in the instance. MSTIs can share the same regional root or have different roots. A regional root is determined by the MSTI priority value and a bridge's MAC address.
- ❑ The regional root of a MSTI must be in the same region as the MSTI.
- ❑ The CIST must have a regional root for communicating with other regions and single-instance spanning trees.
- ❑ MSTP is compatible with STP and RSTP.
- ❑ A port transmits CIST information even when it is associated with another MSTI ID. However, in determining network loops, MSTI takes precedence over CIST. (This is explained more in "Associating VLANs to MSTIs" on page 263.

---

**Note**

The AT-S63 MSTP implementation complies fully with the new IEEE 802.1s standard. Any other vendor's fully compliant 802.1s implementation is interoperable with the AT-S63 implementation.

---

## Associating VLANs to MSTIs

Allied Telesis recommends that you assign all VLANs on a switch to an MSTI. You should not leave a VLAN assigned to just the CIST, including the Default\_VLAN. This is to prevent the blocking of a port that should be in the forwarding state. The reason for this guideline is explained below.

An MSTP BPDUs contains the instance to which the port transmitting the packet belongs. By default, all ports belong to the CIST instance. So CIST is included in the BPDUs. If the port is a member of a VLAN that has been assigned to another MSTI, that information is also included in the BPDUs.

This is illustrated in Figure 30. Port 8 in switch A is a member of a VLAN assigned to MSTI ID 7 while port 1 is a member of a VLAN assigned to MSTI ID 10. The BPDUs transmitted by port 8 to switch B would indicate that the port is a member of both CIST and MSTI 7, while the BPDUs from port 1 would indicate the port is a member of the CIST and MSTI 10.

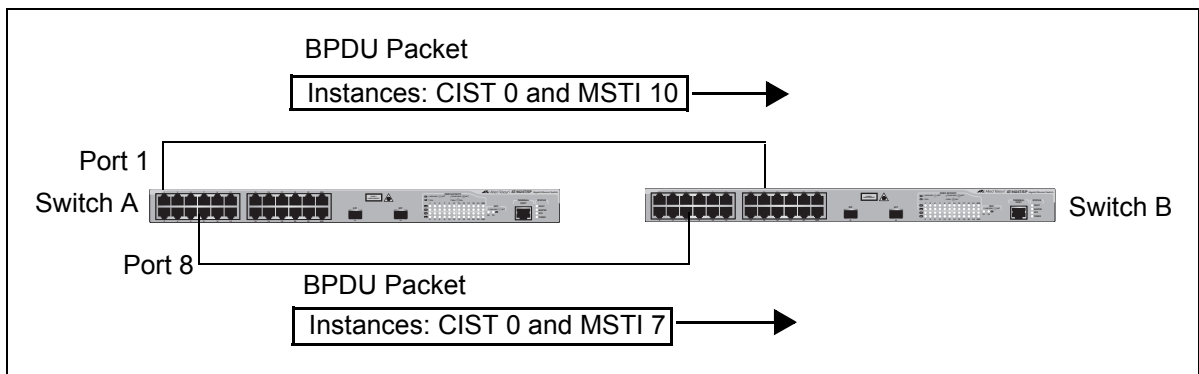

Figure 30. CIST and VLAN Guideline - Example 1

At first glance, it might appear that because both ports belong to CIST, a loop would exist between the switches and that MSTP would block a port to stop the loop. However, within a region, MSTI takes precedence over CIST. When switch B receives a packet from switch A, it uses MSTI, not CIST, to determine whether a loop exists. And because both ports on switch A belong to different MSTIs, switch B determines that no loop exists.

A problem can arise if you assign some VLANs to MSTIs while leaving others just to CIST. The problem is illustrated in Figure 31. The network is the same as the previous example. The only difference is that the VLAN containing port 8 on Switch A has not been assigned to an MSTI, and belongs only to CIST with its MSTI ID 0.

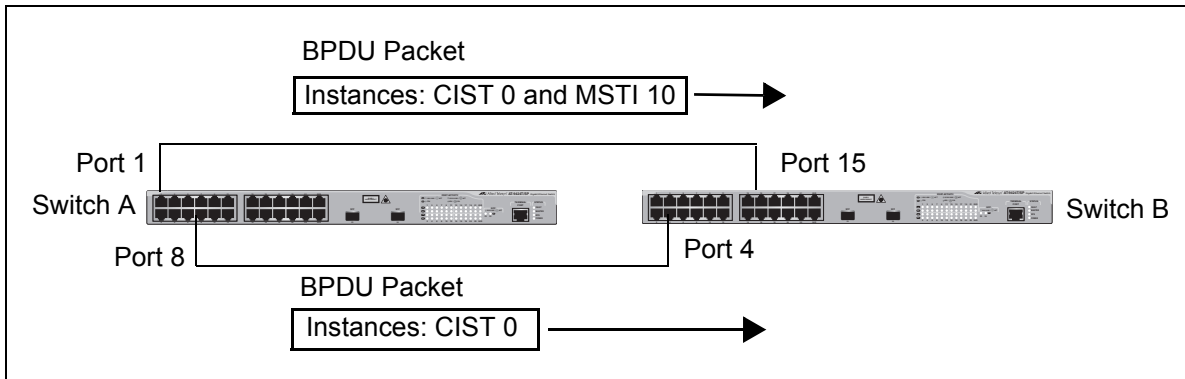

Figure 31. CIST and VLAN Guideline - Example 2

When port 4 on switch B receives a BPDUs, the switch notes the port sending the packet belongs only to CIST. Therefore, switch B uses CIST in determining whether a loop exists. The result would be that the switch detects a loop because the other port is also receiving BPDUs packets from CIST 0. Switch B would block a port to cancel the loop.

To avoid this issue, always assign all VLANs on a switch, including the Default\_VLAN, to an MSTI. This guarantees that all ports on the switch have an MSTI ID and that helps to ensure that loop detection is based on MSTI, not CIST.



## Connecting VLANs Across Different Regions

Special consideration needs to be taken into account when you connect different MSTP regions or an MSTP region and a single-instance STP or RSTP region. Unless planned properly, VLAN fragmentation can occur between the VLANs of your network.

As mentioned previously, only the CIST can span regions. A MSTI cannot. Consequently, you may run into a problem if you use more than one physical data link to connect together various parts of VLANs that reside in bridges in different regions. The result can be a physical loop, which spanning tree disables by blocking ports.

This is illustrated in Figure 32. The example shows two switches, each residing in a different region. Port 1 in switch A is a boundary port. It is an untagged member of the Accounting VLAN, which has been associated with MSTI 4. Port 16 is a tagged and untagged member of three different VLANs, all associated to MSTI 12.

If both switches were a part of the same region, there would be no problem because the ports reside in different spanning tree instances. However, the switches are part of different regions and MSTIs do not cross regions. Consequently, the result is that spanning tree would determine that a loop exists between the regions, and Switch B would block a port.

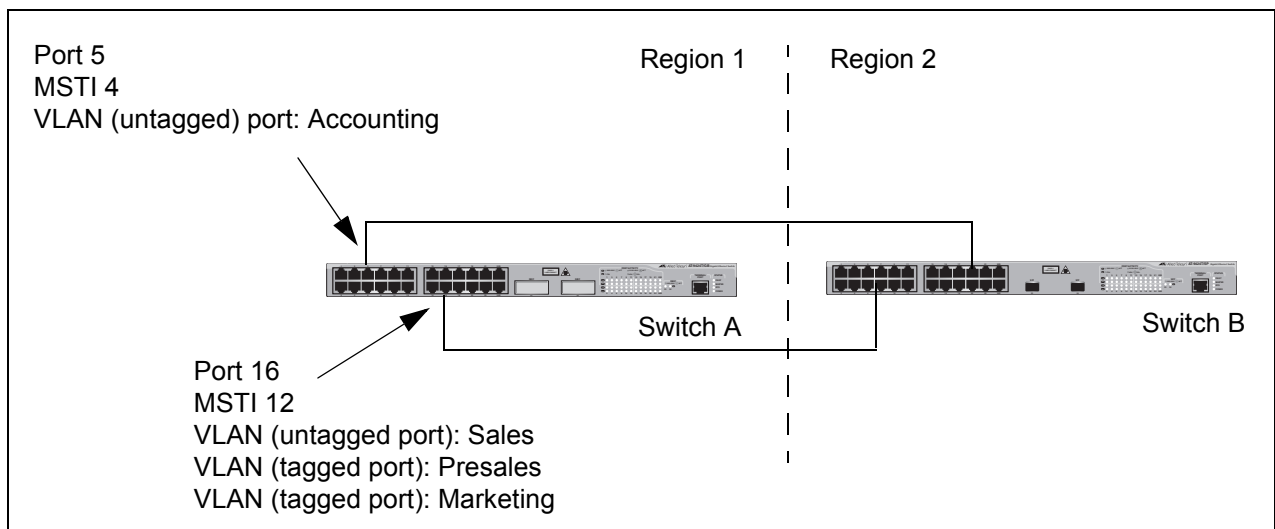

Figure 32. Spanning Regions - Example 1

There are several ways to address this issue. One is to have only one MSTP region for each subnet in your network.

Another approach is to group those VLANs that need to span regions into the same MSTI. Those VLANs that do not span regions can be assigned to other MSTIs.

Here is an example. Assume that you have two regions that contain the following VLANs:

Region 1 VLANs

Sales  
Presales  
Marketing  
Advertising  
Technical Support  
Product Management  
Project Management  
Accounting

Region 2 VLANs

Hardware Engineering  
Software Engineering  
Technical Support  
Product Management  
CAD Development  
Accounting

The two regions share three VLANs: Technical Support, Product Management, and Accounting. You could group those VLANs into the same MSTI in each region. For instance, for Region 1 you might group the three VLANs in MSTI 11 and in Region 2 you could group them into MSTI 6. After they are grouped, you can connect the VLANs across the regions using a link of tagged ports.

## Section VI

# Virtual LANs

---

The chapters in this section discuss the various types of virtual LANs supported by the AT-9400 Switch. The chapters include:

- ❑ Chapter 24, “Port-based and Tagged VLANs” on page 269
- ❑ Chapter 25, “GARP VLAN Registration Protocol” on page 283
- ❑ Chapter 26, “Multiple VLAN Modes” on page 295
- ❑ Chapter 27, “Protected Ports VLANs” on page 301
- ❑ Chapter 28, “MAC Address-based VLANs” on page 307



## Chapter 24

# Port-based and Tagged VLANs

---

This chapter contains overview information about port-based and tagged virtual LANs (VLANs). This chapter contains the following sections:

- ❑ “Supported Platforms” on page 270
- ❑ “Overview” on page 271
- ❑ “Port-based VLAN Overview” on page 273
- ❑ “Tagged VLAN Overview” on page 279

## Supported Platforms

---

Refer to Table 78 and Table 79 for the AT-9400 Switches and the management interfaces that support the port-based and tagged VLANs.

Table 78. Support for the Port-based and Tagged VLANs

Switch	Supported
Layer 2+ Models	
AT-9408LC/SP	Yes
AT-9424T/GB	Yes
AT-9424T/SP	Yes
Basic Layer 3 Models	
AT-9424T	Yes
AT-9424T/POE	Yes
AT-9424Ts	Yes
AT-9424Ts/XP	Yes
AT-9448T/SP	Yes
AT-9448Ts/XP	Yes
AT-9400Ts Stack	Yes

Table 79. Management Interfaces for the Port-based and Tagged VLANs

Switch or Stack	Standard Command Line	AlliedWare Plus Command Line	Menus	Web Browser
Stand-alone Switch	Yes	Yes	Yes	Yes
AT-9400Ts Stack	Yes	Yes		Yes

## Overview

---

A VLAN is a group of ports on an Ethernet switch that form a logical Ethernet segment. The ports of a VLAN form an independent traffic domain where the traffic generated by the nodes of a VLAN remains within the VLAN.

With VLANs, you can segment your network through the switch's AT-S63 Management Software and so be able to group nodes with related functions into their own separate, logical LAN segments. These VLAN groupings can be based on similar data needs or security requirements. For example, you could create separate VLANs for the different departments in your company, such as one for Sales and another for Accounting.

VLANs offer several important benefits:

- ❑ Improved network performance

Network performance often suffers as networks grow in size and as traffic increases. The more nodes on each LAN segment vying for bandwidth, the greater the likelihood overall network performance decreases.

VLANs improve network perform because VLAN traffic stays within the VLAN. The nodes of a VLAN receive traffic only from nodes of the same VLAN. This reduces the need for nodes to handle traffic not destined for them. It also frees up bandwidth within all the logical workgroups.

In addition, because each VLAN constitutes a separate broadcast domain, broadcast traffic remains within the VLAN. This too can improve overall network performance.

- ❑ Increased security

Because network traffic generated by a node in a VLAN is restricted only to the other nodes of the same VLAN, you can use VLANs to control the flow of packets in your network and prevent packets from flowing to unauthorized end nodes.

- ❑ Simplified network management

VLANs can also simplify network management. Before the advent of VLANs, physical changes to the network often had to been made at the switches in the wiring closets. For example, if an employee changed departments, changing the employee's LAN segment assignment often required a change to the wiring at the switch.

But with VLANS, you can change the LAN segment assignment of an end node connected to the switch using the switch's AT-S63

Management Software. You can change the VLAN memberships through the management software without moving the workstations physically, or changing group memberships by moving cables from one switch port to another.

In addition, a virtual LAN can span more than one switch. This means that the end nodes of a VLAN do not need to be connected to the same switch and so are not restricted to being in the same physical location.

The AT-9400 Switch supports the following types of VLANs you can create yourself:

- Port-based VLANs
- Tagged VLANs

These VLANs are described in the following sections.



## Port-based VLAN Overview

---

As explained in “Overview” on page 271, a VLAN consists of a group of ports on one or more Ethernet switches that form an independent traffic domain. Traffic generated by the end nodes of a VLAN remains within the VLAN and does not cross over to the end nodes of other VLANs unless there is an interconnection device, such as a router or Layer 3 switch.

A port-based VLAN is a group of ports on a Gigabit Ethernet Switch that form a logical Ethernet segment. Each port of a port-based VLAN can belong to only one VLAN at a time.

A port-based VLAN can have as many or as few ports as needed. The VLAN can consist of all the ports on an Ethernet switch, or just a few ports. A port-based VLAN also can span switches and consist of ports from multiple Ethernet switches.

---

### Note

The AT-9400 Switch is preconfigured with one port-based VLAN. All ports on the switch are members of this VLAN, called the Default\_VLAN.

---

The parts that make up a port-based VLAN are:

- VLAN name
- VLAN Identifier
- Untagged ports
- Port VLAN Identifier

**VLAN Name** To create a port-based VLAN, you must give it a name. The name should reflect the function of the network devices that are members of the VLAN. Examples include Sales, Production, and Engineering.

**VLAN Identifier** Every VLAN in a network must have a unique number assigned to it. This number is called the VLAN identifier (VID). This number uniquely identifies a VLAN in the switch and the network.

If a VLAN consists only of ports located on one physical switch in your network, you assign it a VID different from all other VLANs in your network.

If a VLAN spans multiple switches, then the VID for the VLAN on the different switches should be the same. The switches are then able to recognize and forward frames belonging to the same VLAN even though the VLAN spans multiple switches.

For example, if you had a port-based VLAN titled Marketing that spanned

three AT-9400 Switches, you would assign the Marketing VLAN on each switch the same VID.

You can assign this number manually or allow the AT-S63 Management Software to do it automatically. If you allow the management software to do it automatically, it selects the next available VID. This is acceptable when you are creating a new, unique VLAN.

If you are creating a VLAN on a switch that will be part of a larger VLAN that spans several switch, then you will need to assign the number yourself so that the VLAN has the same VID on all switches.

## Untagged Ports

You need to specify which ports on the switch are to be members of a port-based VLAN. Ports in a port-based VLAN are referred to as *untagged ports* and the frames received on the ports as *untagged frames*. The names derive from the fact that the frames received on a port will not contain any information that indicates VLAN membership, and that VLAN membership will be determined solely by the port's PVID. (There is another type of VLAN where VLAN membership is determined by information within the frames themselves, rather than by a port's PVID. This type of VLAN is explained in "Tagged VLAN Overview" on page 279.)

A port on a switch can be an untagged member of only one port-based VLAN at a time. An untagged port cannot be assigned to two port-based VLANs simultaneously.

## Port VLAN Identifier

Each port in a port-based VLAN must have a port VLAN identifier (PVID). The switch associates a frame to a port-based VLAN by the PVID assigned to the port on which the frame is received, and forwards the frame only to those ports with the same PVID. Consequently, all ports of a port-based VLAN must have the same PVID. Additionally, the PVID of the ports in a VLAN must match the VLAN's VID.

For example, if you were creating a port-based VLAN on a switch and you had assigned the VLAN the VID 5, the PVID for each port in the VLAN would need to be assigned the value 5.

Some switches and switch management programs require that you assign the PVID value for each port manually. However, the AT-S63 Management Software performs this task automatically. The software automatically assigns a PVID to a port, making it identical to the VID of the VLAN to which the port is a member, when you assign the port as an untagged member to a VLAN.

## **Guidelines to Creating a Port-based VLAN**

Below are the guidelines to creating a port-based VLAN.

- ❑ Each port-based VLAN must be assigned a unique VID. If a particular VLAN spans multiples switches, each part of the VLAN on the different switches should be assigned the same VID.
- ❑ A port can be an untagged member of only one port-based VLAN at a time.
- ❑ The PVID of a port is identical to the VID of the VLAN where the port is an untagged member. The PVID value is automatically assigned by the AT-S63 Management Software.
- ❑ A port-based VLAN that spans multiple switches requires a port on each switch where the VLAN is located to function as an interconnection between the switches where the various parts of the VLAN reside.
- ❑ The switch can support up to a total of 4094 port-based, tagged, protected ports, and MAC address-based VLANs.
- ❑ A port set to the 802.1x authenticator or supplicant role must be changed to the 802.1x none role before you can change its untagged VLAN assignment. After the VLAN assignment is made, the port's role can be changed back again to authenticator or supplicant, if desired.
- ❑ You cannot delete the Default VLAN from the switch.
- ❑ Deleting an untagged port from the Default VLAN without assigning it to another VLAN results in the port being an untagged member of no VLAN.

## **Drawbacks of Port-based VLANs**

There are several drawbacks to port-based VLANs:

- ❑ It is not easy to share network resources, such as servers and printers, across multiple VLANs. A router or Layer 3 switch must be added to the network to provide a means for interconnecting the port-based VLANs. The introduction of a router into your network could create security issues from unauthorized access to your network.
- ❑ A VLAN that spans several switches requires a port on each switch for the interconnection of the various parts of the VLAN. For example, a VLAN that spans three switches would require one port on each switch to interconnect the various sections of the VLAN. In network configurations where there are many individual VLANs that span switches, many ports could end up being used ineffectively just to interconnect the various VLANs.

**Port-based Example 1**

Figure 33 illustrates an example of one AT-9424T/SP Gigabit Ethernet Switch with three port-based VLANs. (For purposes of the following examples, the Default\_VLAN is not shown.)

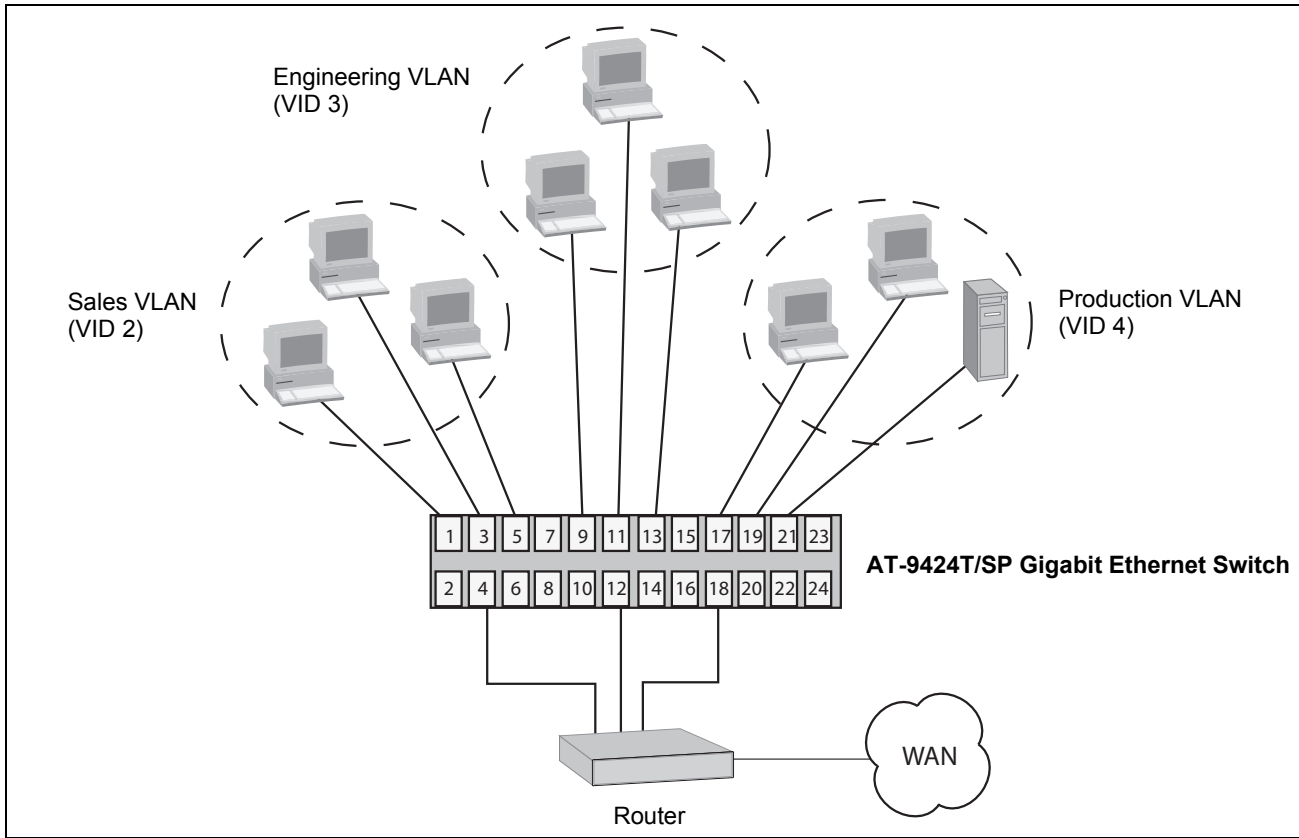

Figure 33. Port-based VLAN - Example 1

The table below lists the port assignments for the Sales, Engineering, and Production VLANs on the switch.

	<b>Sales VLAN (VID 2)</b>	<b>Engineering VLAN (VID 3)</b>	<b>Production VLAN (VID 4)</b>
AT-9424T/SP Switch	Ports 1, 3 - 5 (PVID 2)	Ports 9, 11 - 13 (PVID 3)	Ports 17 - 19, 21 (PVID 4)

Each VLAN has a unique VID. This number is assigned when you create a VLAN.

The ports have been assigned PVID values. A port’s PVID is assigned automatically by the AT-S63 Management Software when you create the VLAN. The PVID of a port is the same as the VID to which the port is an untagged member.

In the example, each VLAN has one port connected to the router. The router interconnects the various VLANs and functions as a gateway to the WAN.

**Port-based  
Example 2**

Figure 34 illustrates more port-based VLANs. In this example, two VLANs, Sales and Engineering, span two AT-9400 Switches Gigabit Ethernet switches.

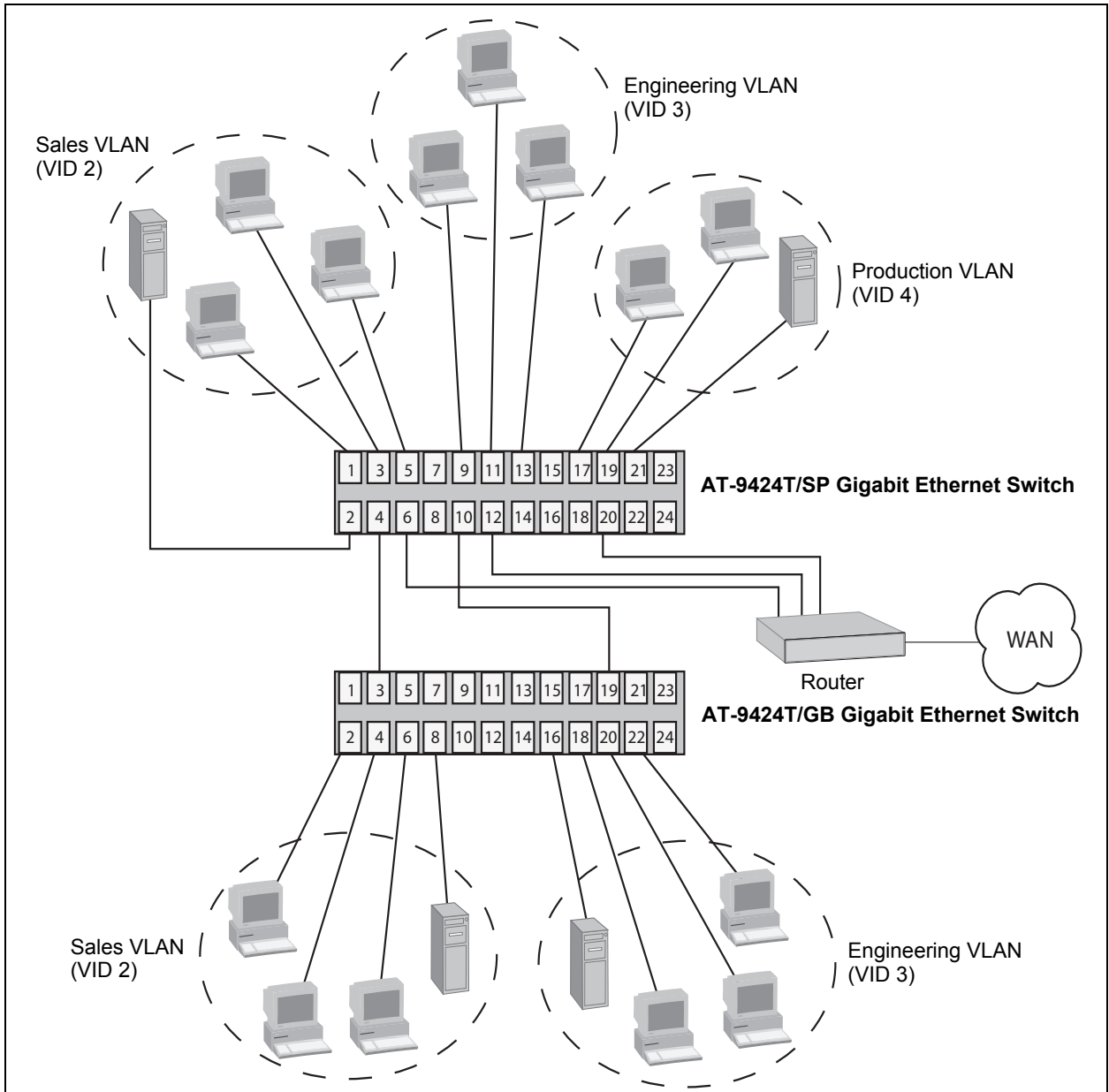

Figure 34. Port-based VLAN - Example 2

The table below lists the port assignments for the Sales, Engineering, and Production VLANs on the switches:

	<b>Sales VLAN (VID 2)</b>	<b>Engineering VLAN (VID 3)</b>	<b>Production VLAN (VID 4)</b>
AT-9424T/SP Switch (top)	Ports 1 - 6 (PVID 2)	Ports 9 - 13 (PVID 3)	Ports 17, 19 - 21 (PVID 4)
AT-9424T/GB Switch (bottom)	Ports 2 - 4, 6, 8 (PVID 2)	Ports 16, 18-20, 22 (PVID 3)	none

- ❑ Sales VLAN - This VLAN spans both switches. It has a VID value of 2 and consists of six untagged ports on the top switch and five untagged ports on the bottom switch.

The two parts of the VLAN are connected by a direct link from port 4 on the top switch to port 3 on the bottom switch. This direct link allows the two parts of the Sales VLAN to function as one logical LAN segment.

Port 6 on the top switch connects to the router. This port allows the Sales VLAN to exchange Ethernet frames with the other VLANs and to access the WAN.

- ❑ Engineering VLAN - The workstations of this VLAN are connected to ports 9 to 13 on the top switch and ports 16, 18 to 20, and 22 on the bottom switch.

Because this VLAN spans multiple switches, it needs a direct connection between its various parts to provide a communications path. This is provided in the example with a direct connection from port 10 on the top switch to port 19 on the bottom switch.

This VLAN uses port 12 on the top switch as a connection to the router and the WAN.

- ❑ Production VLAN - This is the final VLAN in the example. It has the VLAN of 4 and its ports have been assigned the PVID also of 4.

The nodes of this VLAN are connected only to the top switch. So this VLAN does not require a direct connection to the bottom switch. However, it uses port 20 as a connection to the router.

## Tagged VLAN Overview

---

The second type of VLAN supported by the AT-S63 Management Software is the *tagged VLAN*. VLAN membership in a tagged VLAN is determined by information within the frames that are received on a port. This differs from a port-based VLAN, where the PVIDs assigned to the ports determine VLAN membership.

The VLAN information within an Ethernet frame is referred to as a *tag* or *tagged header*. A tag, which follows the source and destination addresses in a frame, contains the VID of the VLAN to which the frame belongs (IEEE 802.3ac standard). As explained earlier in this chapter in “VLAN Identifier” on page 273, this number uniquely identifies each VLAN in a network.

When a switch receives a frame with a VLAN tag, referred to as a *tagged frame*, the switch forwards the frame only to those ports that share the same VID.

A port to receive or transmit tagged frames is referred to as a *tagged port*. Any network device connected to a tagged port must be IEEE 802.1Q-compliant. This is the standard that outlines the requirements and standards for tagging. The device must be able to process the tagged information on received frames and add tagged information to transmitted frames.

The benefit of a tagged VLAN is that the tagged ports can belong to more than one VLAN at one time. This can greatly simplify the task of adding shared devices to the network. For example, a server can be configured to accept and return packets from many different VLANs simultaneously.

Tagged VLANs are also useful where multiple VLANs span across switches. You can use one port per switch to connect all VLANs on the switch to another switch.

The IEEE 802.1Q standard describes how this tagging information is used to forward the traffic throughout the switch. The handling of frames tagged with VIDs coming into a port is straightforward. If the incoming frame's VID tag matches one of the VIDs of a VLAN of which the port is a tagged member, the frame is accepted and forwarded to the appropriate ports. If the frame's VID does not match any of the VLANs that the port is a member of, the frame is discarded.

The parts of a tagged VLAN are much the same as those for a port-based VLAN. They are:

- VLAN Name
- VLAN Identifier
- Tagged and Untagged Ports

- Port VLAN Identifier

---

**Note**

For explanations of VLAN name and VLAN identifier, refer back to “VLAN Name” on page 273 and “VLAN Identifier” on page 273.

---

## Tagged and Untagged Ports

You need to specify which ports will be members of the VLAN. In the case of a tagged VLAN, it is usually a combination of both untagged ports and tagged ports. You specify which ports are tagged and which untagged when you create the VLAN.

An untagged port, whether a member of a port-based VLAN or a tagged VLAN, can be in only one VLAN at a time. However, a tagged port can be a member of more than one VLAN. A port can also be an untagged member of one VLAN and a tagged member of different VLANs simultaneously.

## Port VLAN Identifier

As explained earlier in the discussion on port-based VLANs, the PVID of a port determines the VLAN where the port is an untagged member.

Because a tagged port determines VLAN membership by examining the tagged header within the frames that it receives and not the PVID, you could conclude that there is no need for a PVID. However, the PVID is used if a tagged port receives an untagged frame—a frame without any tagged information. The port forwards the frame based on the port’s PVID. This is only in cases where an untagged frame arrives on a tagged port. Otherwise, the PVID on a tagged port is ignored.

## Guidelines to Creating a Tagged VLAN

Below are the guidelines to creating a tagged VLAN.

- Each tagged VLAN must be assigned a unique VID. If a particular VLAN spans multiple switches, each part of the VLAN on the different switches must be assigned the same VID.
- A tagged port can be a member of multiple VLANs.
- An untagged port can be an untagged member of only one VLAN at a time.
- The switch can support up to a total of 4094 port-based, tagged, protected ports, and MAC address-based VLANs.



**Tagged VLAN Example**

Figure 35 illustrates how tagged ports can be used to interconnect IEEE 802.1Q-based products.

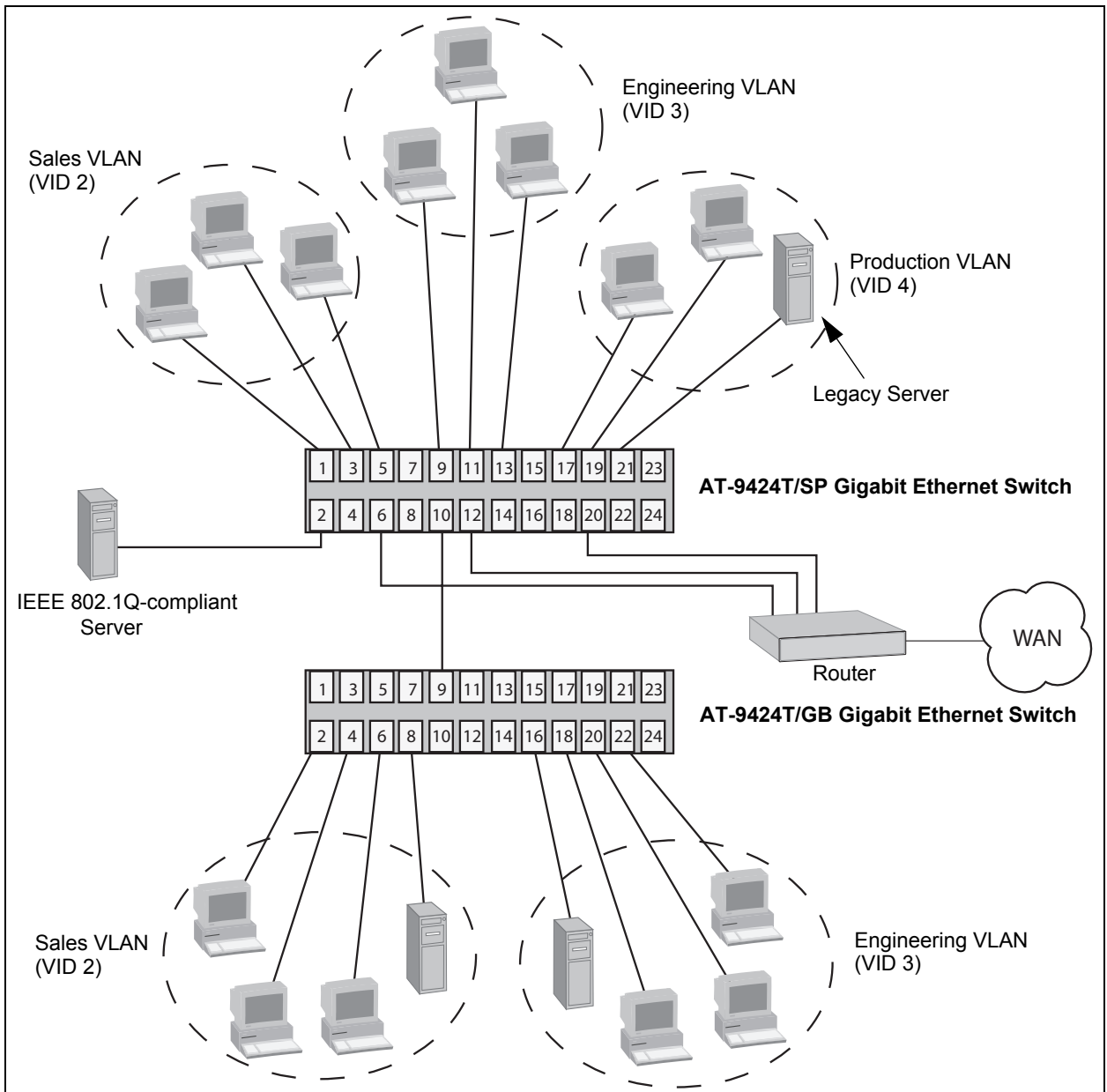

Figure 35. Example of a Tagged VLAN

The port assignments for the VLANs are as follows:

	Sales VLAN (VID 2)		Engineering VLAN (VID 3)		Production VLAN (VID 4)	
	Untagged Ports	Tagged Ports	Untagged Ports	Tagged Ports	Untagged Ports	Tagged Ports
AT-9424T/ SP Switch (top)	1, 3 to 5 (PVID 2)	2, 10	9, 11 to 13 (PVID 3)	2, 10	17, 19 to 21 (PVID 4)	2
AT-9424T/ GB Switch (bottom)	2, 4, 6, 8 (PVID 2)	9	16, 18, 20, 22 (PVID 3)	9	none	none

This example is nearly identical to the “Port-based Example 2” on page 277. Tagged ports have been added to simplify network implementation and management.

One of the tagged ports is port 2 on the top switch. This port has been made a tagged member of the three VLANs. It is connected to an IEEE 802.1Q-compliant server, meaning the server can handle frames from multiple VLANs. Now all three VLANs can access the server without going through a router or other interconnection device.

It is important to note that even though the server is accepting frames from and transmitting frames to more than one VLAN, data separation and security remain.

Two other tagged ports are used to simplify network design in the example. They are port 10 on the top switch and port 9 on the lower switch. These ports have been made tagged members of the Sales and Engineering VLANs so that they can carry traffic from both VLANs, simultaneously. These ports provide a common connection that enables different parts of the same VLAN to communicate with each other while maintaining data separation between VLANs.

In comparison, the Sales and Engineering VLANs in the “Port-based Example 2” on page 277 each had to have its own individual network link between the switches to connect the different parts of the VLANs. But with tagged ports, you can use one data link to carry data traffic from several VLANs, while still maintaining data separation and security. The tagged frames, when received by the switch, are delivered only to those ports that belong to the VLAN from which the tagged frame originated.

## Chapter 25

# GARP VLAN Registration Protocol

---

This chapter describes the GARP VLAN Registration Protocol (GVRP) and contains the following sections:

- ❑ “Supported Platforms” on page 284
- ❑ “Overview” on page 285
- ❑ “Guidelines” on page 288
- ❑ “GVRP and Network Security” on page 289
- ❑ “GVRP-inactive Intermediate Switches” on page 290
- ❑ “Generic Attribute Registration Protocol (GARP) Overview” on page 291

## Supported Platforms

Refer to Table 80 and Table 81 for the AT-9400 Switches and the management interfaces that support the GARP VLAN Registration Protocol.

Table 80. Support for the GARP VLAN Registration Protocol

Switch	Supported
Layer 2+ Models	
AT-9408LC/SP	Yes
AT-9424T/GB	Yes
AT-9424T/SP	Yes
Basic Layer 3 Models	
AT-9424T	Yes
AT-9424T/POE	Yes
AT-9424Ts	Yes
AT-9424Ts/XP	Yes
AT-9448T/SP	Yes
AT-9448Ts/XP	Yes
AT-9400Ts Stack	

Table 81. Management Interfaces for the GARP VLAN Registration Protocol

Switch or Stack	Standard Command Line	AlliedWare Plus Command Line	Menus	Web Browser
Stand-alone Switch	Yes		Yes	Yes
AT-9400Ts Stack				

## Overview

---

The GARP VLAN Registration Protocol (GVRP) allows network devices to share VLAN information. The main purpose of GVRP is to allow switches to automatically discover some of the VLAN information that would otherwise need to be manually configured in each switch. This is helpful in networks where VLANs span more than one switch. Without GVRP, you must manually configure your switches to ensure that the various parts of a VLAN can communicate across the different switches. GVRP, which is an application of the Generic Attribute Registration Protocol (GARP), does this for you automatically.

The AT-S63 Management Software uses GVRP protocol data units (PDUs) to share VLAN information among GVRP-active devices. The PDUs contain the VID numbers of the VLANs on the switch. A PDU contains the VID of all the VLANs on the switch, not just the VID of which the transmitting port is a member.

When a switch receives a GVRP PDU on a port, it examines the PDU to determine the VID of the VLANs on the device that sent it. It then does the following:

- ❑ If a VLAN does not exist on the switch, it creates the VLAN and adds the port as a tagged member to the VLAN. A VLAN created by GVRP is called a *dynamic GVRP VLAN*.
- ❑ If the VLAN already exists on the switch but the port is not a member of it, the switch adds the port as a tagged member. A port that has been added by GVRP to a static VLAN (that is a user-created VLAN) is called a *dynamic GVRP port*.

You cannot modify a dynamic GVRP VLAN. After it is created, only GVRP can modify or delete it. A dynamic GVRP VLAN exists only so long as there are active nodes in the network that belong to the VLAN. If all nodes of a dynamic GVRP VLAN are shut down and there are no active links, the VLAN is deleted from the switch.

A dynamic GVRP port in a static VLAN remains a member of the VLAN as long as there are active VLAN members. If all members of the VLAN become inactive or there are no active links, GVRP removes the dynamic port from the VLAN, but does not delete the VLAN if the VLAN is a static VLAN.

Figure 36 provides an example of how GVRP works.

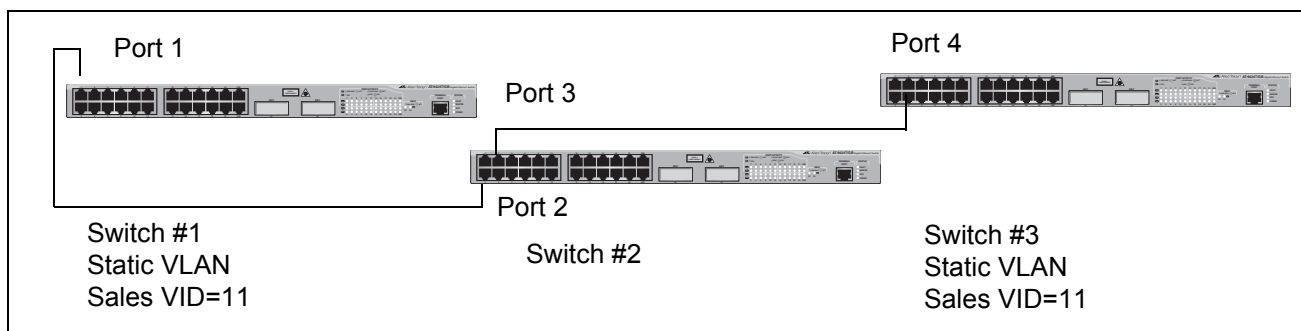

Figure 36. GVRP Example

Switches #1 and #3 contain the Sales VLAN, but switch #2 does not. Consequently, the end nodes of the two parts of the Sales VLANs are unable to communicate with each other.

Without GVRP, you would need to configure switch #2 by creating the Sales VLAN on the switch and adding ports 2 and 3 as members of the VLAN. If you happen to have a large network with a large number of VLANs, such manual configurations can be cumbersome and time consuming.

GVRP can make the configurations for you. Here is how GVRP would resolve the problem in the example.

1. Port 1 on switch #1 sends a PDU to port 2 on switch #2, containing the VID of all the VLANs on the switch. One of the VIDs in the PDU would be that of the Sales VLAN, VID 11.
2. Switch #2 examines the PDU it receives on port 2 and notes that it does not have a VLAN with a VID 11. So it creates the VLAN as a dynamic GVRP VLAN and assigns it a VID 11 and the name GVRP\_VLAN\_11. (The name of a dynamic GVRP VLAN has the prefix "GVRP\_VLAN\_", followed by the VID number.) The switch then adds port 2, the port that received the PDU, as a tagged member of the VLAN.
3. Switch #2 sends a PDU out port 3 containing all of the VIDs of the VLANs on the switch, including the new GVRP\_VLAN\_11 with its VID of 11. (Note that port 3 is not yet a member of the VLAN. Ports are added to VLANs when they receive, not send a PDU.)
4. Switch #3 receives the PDU on port 4 and, after examining it, notes that one of the VLANs on switch #2 has the VID 11, which matches the VID of an already existing VLAN on the switch. So it does not create the VLAN because it already exists. It then determines whether the port that received the PDU, in this case port 4, is a member of the VLAN. If it is not a member, it automatically adds the port to the VLAN.

as an tagged dynamic GVRP port. If the port is already a member of the VLAN, then no change is made.

5. Switch #3 sends a PDU out port 4 to switch #2.
6. Switch #2 receives the PDU on port 3 and then adds the port as a tagged dynamic GVRP port to the dynamic GVRP\_VLAN\_11 VLAN.

There is now a communications path for the end nodes of the Sales VLAN on switches #1 and #3. GVRP created the new GVRP\_VLAN\_11 dynamic GVRP VLAN with a VID of 11 on switch #2 and added ports 2 and 3 to the VLAN as tagged dynamic GVRP ports.

## Guidelines

---

Following are guidelines to observe when using this feature:

- ❑ GVRP is supported with STP and RSTP, or without spanning tree. GVRP is not supported with MSTP.
- ❑ GVRP is supported when the switch is operating in the tagged VLAN mode, which is the VLAN mode for creating your own tagged and port-based VLANs.
- ❑ GVRP is not supported when the switch is operating in either of the multiple VLAN modes.
- ❑ Both ports that constitute a network link between the switch and the other device must be running GVRP.
- ❑ You cannot modify or delete a dynamic GVRP VLAN.
- ❑ You cannot remove a dynamic GVRP port from a static or dynamic VLAN.
- ❑ GVRP can only detect a VLAN where there are active nodes, or where at least one end node of a VLAN has established a valid link with a switch. GVRP will not be aware of a VLAN where there are no active end nodes or if no end nodes have established a link with the switch.
- ❑ Resetting a switch erases all dynamic GVRP VLANs and dynamic GVRP port assignments. The switch relearns the dynamic assignments as it receives PDUs from the other switches.
- ❑ GVRP has three timers that you can set: join timer, leave timer, and leave all timer. The values for these timers must be set the same on all switches running GVRP. Timers with different values on different switches can result in GVRP compatibility problems.
- ❑ You can convert dynamic GVRP VLANs and dynamic GVRP port assignments to static VLANs and static port assignments.
- ❑ The default port settings on the switch for GVRP is active, meaning that the ports participate in GVRP. Allied Telesis recommends disabling GVRP on those ports that are connected to GVRP-inactive devices, meaning devices that do not feature GVRP.
- ❑ PDUs are transmitted to only those switch ports where GVRP is enabled.



## GVRP and Network Security

---

GVRP should be used with caution because it can expose your network to unauthorized access. A network intruder can access to restricted parts of the network by connecting to a switch port running GVRP and transmitting a bogus GVRP PDU containing VID's of restricted VLANs. GVRP would make the switch port a member of the VLANs and that could give the intruder access to restricted areas of your network.

To protect against this type of network intrusion, consider the following:

- ❑ Activating GVRP only on those switch ports that are connected to other devices that support GVRP. Do not activate GVRP on ports that are connected to GVRP-inactive devices.
- ❑ Converting all dynamic GVRP VLANs and dynamic GVRP ports to static assignments, and then turning off GVRP on all switches. This preserves the new VLAN assignments while protecting against network intrusion.

## **GVRP-inactive Intermediate Switches**

---

If two GVRP-active devices are separated by a GVRP-inactive switch, the GVRP-active devices may not be able to share VLAN information. There are two issues involved.

The first is whether the intermediate switch forwards the GVRP PDUs that it receives from the GVRP-active switches. GVRP PDUs are management frames, intended for a switch's CPU. In all likelihood, a GVRP-inactive switch will discard the PDUs because it does not recognize them.

The second issue is that even if the GVRP-inactive switch forwards GVRP PDUs, it will not create the VLANs, at least not automatically. Consequently, even if the GVRP-active switches receive the PDUs and create the necessary VLANs, the intermediate switch may block the VLAN traffic, unless you modify its VLANs and port assignments manually.

## Generic Attribute Registration Protocol (GARP) Overview

---

The following is a technical overview of GARP. An understanding of GARP may prove helpful when you use GVRP.

The purpose of the *Generic Attribute Registration Protocol (GARP)* is to provide a generic framework whereby devices in a bridged LAN, for example end stations and switches, can register and deregister *attribute* values, such as VLAN Identifiers, with each other. In doing so, the attributes are propagated to devices in the bridged LAN, and these devices form a “reachability” tree that is a subset of an active topology. For a bridged LAN, the active topology is normally that created and maintained by the Spanning Tree Protocol (STP).

To use GARP, a GARP application must be defined. The Layer 2 switch has one GARP application presently implemented, GVRP.

The GARP application specifies what the attribute represents.

GARP defines the architecture, rules of operation, state machines and variables for the registration and deregistration of attribute values. By itself, GARP is not directly used by devices in a bridged LAN. It is the applications of GARP that perform meaningful actions. The use of GVRP allows dynamic filter entries for VLAN membership to be distributed among the forwarding databases of VLAN-active switches.

A GARP participant in a switch or an end station consists of a GARP application component, and a *GARP Information Declaration (GID)* component associated with each port of the switch. One such GARP participant exists per port, per GARP application. The *GARP Information Propagation (GIP)* component propagates information between GARP participants for the same application in a switch. Protocol exchanges take place between GARP participants by means of LLC Type 1 services, using the group MAC address and PDU format defined for the GARP application concerned.

Every instance of a GARP application includes a database to store the values of the attributes. Within GARP, attributes are mapped to GID indexes.

GARP architecture is shown in Figure 37.

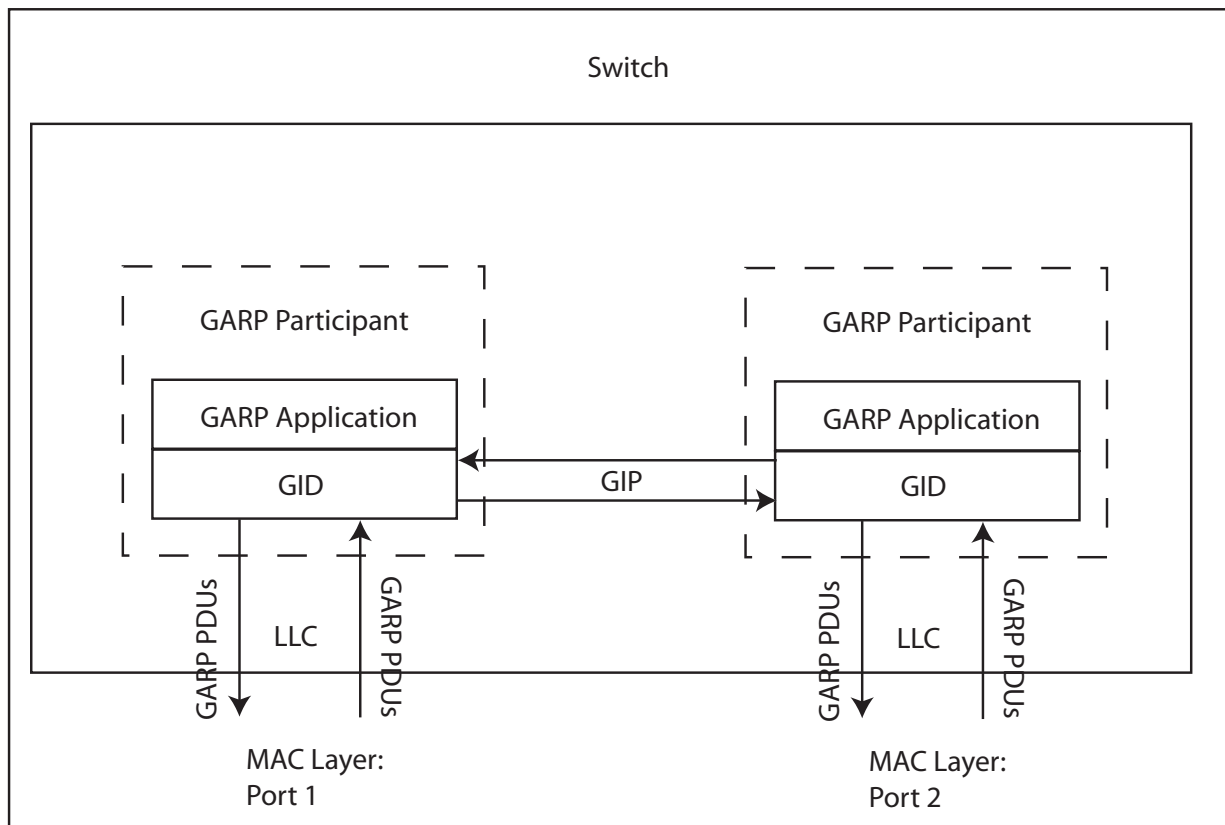

Figure 37. GARP Architecture

The GARP application component of the GARP participant is responsible for defining the semantics associated with the parameter values and operators received in GARP PDUs, and for generating GARP PDUs for transmission. The application uses the GID component, and the state machines associated with the operation of GID, in order to control its protocol interactions.

An instance of GID consists of the set of state machines that define the current registration and declaration state of all *attribute* values associated with the GARP participant. Separate state machines exist for the applicant and registrar. This is shown in Figure 38.

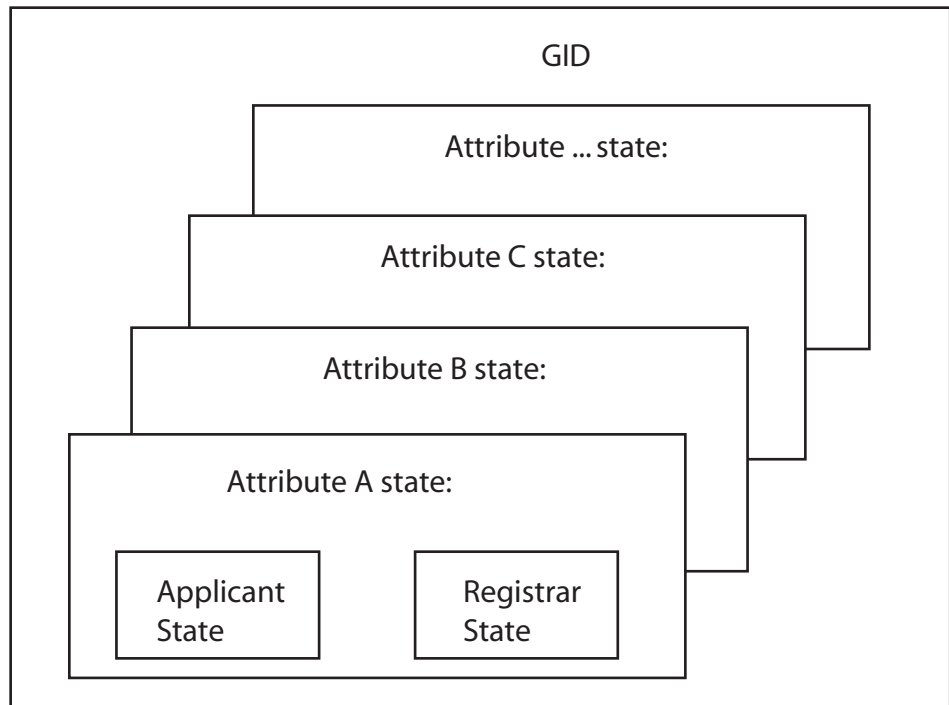

Figure 38. GID Architecture

GARP registers and deregisters *attribute* values through GARP messages sent at the GID level. A GARP participant that wishes to make a declaration (an applicant registering an *attribute* value) sends a JoinIn or JoinEmpty message. An applicant that wishes to withdraw a declaration (deregistering an *attribute* value) sends a LeaveEmpty or LeaveIn message. Following the de-registration of an *attribute* value, the applicant sends a number of Empty messages. The purpose of the Empty message is to prompt other applicants to send JoinIn/JoinEmpty messages. For the GARP protocol to be resilient against multiple lost messages, a LeaveAll message is available. Timers are used in the state machines to generate events and control state transitions.

The job of the applicant is twofold:

- ❑ To ensure that this participant's declarations are registered by other participants' registrars
- ❑ To ensure that other participants have a chance to redeclare (rejoin) after anyone withdraws a declaration (leaves).

The applicant is therefore looking after the interests of all would-be participants. This allows the registrar to be very simple.

The job of the registrar is to record whether an attribute is registered, in the process of being deregistered, or is not registered for an instance of GID.

To control the applicant state machine, an applicant administrative control parameter is provided. This parameter determines whether or not the applicant state machine participates in GARP protocol exchanges. The default value has the applicant participating in the exchanges.

To control the registrar state machine, a registrar administrative control parameter is provided. This parameter determines whether or not the registrar state machine listens to incoming GARP messages. The default value has the registrar listening to incoming GARP messages.

The propagation of information between GARP participants for the same application in a switch is carried out by the GIP component. The operation of GIP is dependent upon STP being enabled on a port, because only ports in the STP Forwarding state are eligible for membership to the GIP connected ring. Ports in the GIP connected ring propagate GID Join and Leave requests to notify each other of attribute registrations and deregistrations. The operation of GIP allows ports in the switch to share information between themselves and the LANs/end stations to which the ports are connected.

If a port enters the STP Forwarding state and the GARP application that the port belongs to is enabled, then the port is added to the GIP connected ring for the GARP application. All attributes registered by other ports in the GIP connected ring is propagated to the recently connected port. All attributes registered by the recently connected port is propagated to all other ports in the GIP connected ring.

Similarly, if a port leaves the STP Forwarding state and the GARP application that the port belongs to is enabled, then the port is removed from the GIP connected ring for the GARP application. Prior to removal, GID leave requests are propagated to all other ports in the GIP connected ring if the port to be removed has previously registered an attribute and no other port in the GIP connected ring has registered that attribute. You can enable or disable GIP operations.

## Chapter 26

# Multiple VLAN Modes

---

This chapter describes the multiple VLAN modes. This chapter contains the following sections:

- ❑ “Supported Platforms” on page 296
- ❑ “Overview” on page 297
- ❑ “802.1Q- Compliant Multiple VLAN Mode” on page 298
- ❑ “Non-802.1Q Compliant Multiple VLAN Mode” on page 300

## Supported Platforms

---

Refer to Table 82 and Table 83 for the AT-9400 Switches and the management interfaces that support the multiple VLAN modes.

Table 82. Support for the Multiple VLAN Modes

Switch	Supported
Layer 2+ Models	
AT-9408LC/SP	Yes
AT-9424T/GB	Yes
AT-9424T/SP	Yes
Basic Layer 3 Models	
AT-9424T	Yes
AT-9424T/POE	Yes
AT-9424Ts	Yes
AT-9424Ts/XP	Yes
AT-9448T/SP	Yes
AT-9448Ts/XP	Yes
AT-9400Ts Stack	

Table 83. Management Interfaces for the Multiple VLAN Modes

Switch or Stack	Standard Command Line	AlliedWare Plus Command Line	Menus	Web Browser
Stand-alone Switch	Yes		Yes	Yes
AT-9400Ts Stack				



## Overview

---

The multiple VLAN modes are designed to simplify the task of configuring the switch in network environments that require a high degree of network segmentation. In a multiple VLAN mode, the ports on a switch are prohibited from forwarding traffic to each other and are only allowed to forward traffic to a user-designated uplink port. These configurations isolate the traffic on each port from all other ports, while providing access to the uplink port.

The AT-S63 Management Software supports two types of multiple VLAN modes:

- ❑ 802.1Q-compliant Multiple VLAN mode
- ❑ Multiple VLAN mode (also referred to as non-802.1Q compliant Multiple VLAN mode)

Each mode uses a different technique to isolate the ports and their traffic. The first method uses VLANs while the second uses port mapping. The uplink port is also different in each mode. In one the port is a tagged port and in the other untagged. This is explained in the following subsections.

---

### Note

The multiple VLAN mode feature is supported only in single switch (i.e. edge switch) environments. This means that cascading of switches while in Multiple VLANs mode is not allowed.

Configuring multiple VLANs on a cascaded switch can possibly result in disconnection of network paths between switches unless the port used to link the switch (being configured for multiple VLANs mode) is configured as uplink VLAN port.

Configuring multiple VLANs on cascaded switches can also affect enhanced stacking because the master switch may not be able to detect member switches beyond the first cascaded switch.

---

## 802.1Q- Compliant Multiple VLAN Mode

---

In this mode, each port is placed into a separate VLAN as an untagged port. The VLAN names and VID numbers are based on the port numbers. For example, the VLAN for port 4 is named Client\_VLAN\_4 and is given the VID of 4, the VLAN for port 5 is named Client\_VLAN\_5 and has a VID of 5, and so on.

The VLAN configuration is accomplished automatically by the switch. After you select the mode and an uplink port, the switch forms the VLANs. It also assigns the PVID values as well. For example, the PVID for port 4 is assigned as 4, to match the VID of 4.

A user-designated port on the switch functions as an uplink port, which can be connected to a shared device such as a router for access to a WAN. This port is placed as a tagged port in each VLAN. Thus, while the switch ports are separated from each other in their individual VLANs, they all have access to the uplink port.

The uplink port also has its own VLAN, where it is an untagged member. This VLAN is called Uplink\_VLAN.

---

### Note

In 802.1Q Multiple VLAN mode, the device connected to the uplink port must be IEEE 802.1Q-compliant.

---

An example of the 802.1Q-compliant VLAN mode is shown in Table 84. The table shows the VLANs on the AT-9400 Switch where port 22 has been selected as the uplink port.

Table 84. 802.1Q-Compliant Multiple VLAN Example

VLAN Name	VID	Untagged Port	Tagged Port
Client_VLAN_1	1	1	22
Client_VLAN_2	2	2	22
Client_VLAN_3	3	3	22
Client_VLAN_4	4	4	22
Client_VLAN_5	5	5	22
Client_VLAN_6	6	6	22
Client_VLAN_7	7	7	22
Client_VLAN_8	8	8	22
Client_VLAN_9	9	9	22

Table 84. 802.1Q-Compliant Multiple VLAN Example (Continued)

VLAN Name	VID	Untagged Port	Tagged Port
Client_VLAN_10	10	10	22
Client_VLAN_11	11	11	22
Client_VLAN_12	12	12	22
Client_VLAN_13	13	13	22
Client_VLAN_14	14	14	22
Client_VLAN_15	15	15	22
Client_VLAN_16	16	16	22
Client_VLAN_17	17	17	22
Client_VLAN_18	18	18	22
Client_VLAN_19	19	19	22
Client_VLAN_20	20	20	22
Client_VLAN_21	21	21	22
<b>Uplink_VLAN</b>	22	22	
Client_VLAN_23	23	23	22
Client_VLAN_24	24	24	22

This highly segmented configuration is useful in situations where traffic generated by each end node or network segment connected to a port on the switch needs to be kept separate from all other network traffic, while still allowing access to an uplink to a WAN. Unicast traffic received by the uplink port is effectively directed to the appropriate port and end node and is not directed to any other port on the switch.

The 802.1Q Multiple VLAN configuration is appropriate when the device connected to the uplink port is IEEE 802.1Q compatible, meaning that it can handle tagged packets.

When you select the 802.1Q-compliant VLAN mode, you are asked to specify the uplink VLAN port. You can specify only one uplink port. The switch automatically configures the ports into the separate VLANs.

---

**Note**

The uplink VLAN is the management VLAN. Any remote management of the switch must be made through the uplink VLAN.

---

## Non-802.1Q Compliant Multiple VLAN Mode

---

Unlike the 802.1Q-compliant VLAN mode, which isolates port traffic by placing each port in a separate VLAN, this mode forms one VLAN with a VID of 1 that encompasses all ports. To establish traffic isolation, it uses port mapping. The result, however, is the same. Ports are permitted to forward traffic only to the designated uplink port and to no other port, even when they receive a broadcast packet.

Another difference with this mode is that the uplink port is untagged. Consequently, you would use this mode when the device connected to the uplink port is not IEEE 802.1Q compatible, meaning that the device cannot handle tagged packets.

---

### Note

When the uplink port receives a packet with a destination MAC address that is not in the MAC address table, the port broadcasts the packet to all switch ports. This can result in ports receiving packets that are not intended for them.

Also note that a switch operating in this mode can be remotely managed through any port on the switch, not just the uplink port.

---

## Chapter 27

# Protected Ports VLANs

---

This chapter explains protected ports VLANs. It contains the following sections:

- ❑ “Supported Platforms” on page 302
- ❑ “Overview” on page 303
- ❑ “Guidelines” on page 305

## Supported Platforms

---

Refer to Table 85 and Table 86 for the AT-9400 Switches and the management interfaces that support the protected ports VLANs.

Table 85. Support for the Protected Ports VLANs

Switch	Supported
Layer 2+ Models	
AT-9408LC/SP	Yes
AT-9424T/GB	Yes
AT-9424T/SP	Yes
Basic Layer 3 Models	
AT-9424T	Yes
AT-9424T/POE	Yes
AT-9424Ts	Yes
AT-9424Ts/XP	Yes
AT-9448T/SP	Yes
AT-9448Ts/XP	Yes
AT-9400Ts Stack	

Table 86. Management Interfaces for the Protected Ports VLANs

Switch or Stack	Standard Command Line	AlliedWare Plus Command Line	Menus	Web Browser
Stand-alone Switch	Yes		Yes	
AT-9400Ts Stack				

## Overview

---

The purpose of a protected ports VLAN is to allow multiple ports on the switch to share the same uplink port but not share traffic with each other.

This feature has some of the same characteristics as the multiple VLAN modes described in the previous chapter, but it offers several advantages. One is that it provides more flexibility. With the multiple VLAN modes, you can select only one uplink port which is shared by all the other ports. Also, you are not allowed to modify the configuration. With protected ports VLANs, you can create LAN segments that consist of more than one port and you can specify multiple uplink ports.

Another advantage is that the switch can support protected ports VLANs as well as port-based and tagged VLANs simultaneously, something that is not allowed with the multiple VLAN modes.

An important concept of this feature is *groups*. A group is a selection of one or more ports that function as a LAN segment within the VLAN. The ports in each group are independent of the ports in the other groups of the VLAN. The ports of a group can share traffic only amongst themselves and with the uplink port, but not with ports in other groups of the VLAN.

A protected ports VLAN can consist of two or more groups and a group can consist of one or more ports. The ports of a group can be either tagged or untagged.

This type of VLAN also shares some common features with tagged VLANs, where one or more ports are shared by different LAN segments. But there are significant differences. First, all the ports in a tagged VLAN are considered a LAN segment, while the ports in a protected ports VLAN, though residing within a single VLAN, are subdivided into the smaller unit of groups, which represent the LAN segments.

Second, a tagged VLAN, by its nature, contains one or more tagged ports. These are the ports that are shared among one or more tagged VLANs. The device connected to a tagged port must be 802.1Q compliant and it must be able to handle tagged packets.

In contrast, the uplink port in a protected ports VLAN, which is shared by the ports in the different groups, can be either tagged or untagged. The device connected to it does not necessarily need to be 802.1Q compliant.

---

### Note

For explanations of VLANs and tagged and untagged ports, refer to Chapter 24, "Port-based and Tagged VLANs" on page 269.

---

To create a protected ports VLAN, you perform many of the same steps that you do when you create a new port-based or tagged VLAN. You give it a name and a unique VID, and you indicate which of the ports will be tagged and untagged. What makes creating this type of VLAN different is that you must assign the ports of the VLAN to their respective groups.

Following is an example of a protected ports VLAN. The first table lists the name of the VLAN, the VID, and the tagged and untagged ports. It also indicates which port will function as the uplink port, in this case port 22. The second table lists the different groups in the VLAN and the ports for each group.

<b>Name</b>	Internet_VLAN_1
<b>VID</b>	8
<b>Untagged Ports in VLAN</b>	1-10, 25
<b>Tagged Ports in VLAN</b>	none
<b>Uplink Port(s)</b>	22

<b>Group Number</b>	<b>Port(s)</b>
1	1-2
2	3
3	4
4	5-7
5	8
6	9-10

Allied Telesis recommends that you create tables similar to these before you create your own protected ports VLAN. Having the tables handy will make your job easier when the switch prompts you for this information.



## Guidelines

---

Following are the guidelines for implementing protected ports VLANs:

- ❑ A protected ports VLAN should contain a minimum of two groups. A protected ports VLAN of only one group can be replaced with a port-based or tagged VLAN instead.
- ❑ A protected ports VLAN can contain any number of groups.
- ❑ A group can contain any number of ports.
- ❑ The ports of a group can be tagged or untagged.
- ❑ Each group must be assigned a unique group number on the switch. The number can be from 1 to 256.
- ❑ A protected ports VLAN can contain more than one uplink port.
- ❑ The switch can support up to a total of 4094 port-based, tagged, protected ports, and MAC address-based VLANs.
- ❑ Uplink ports can be either tagged or untagged.
- ❑ Uplink ports can be shared among more than one protected ports VLAN, but only if they are tagged.
- ❑ A switch can contain a combination of port-based and tagged VLANs and protected ports VLANs.
- ❑ A port that is a member of a group in a protected ports VLAN cannot be a member of a port-based or tagged VLAN.
- ❑ A group can be a member of more than one protected ports VLAN at a time. However, the port members of the group must be identical in both VLANs and the ports must be tagged.
- ❑ You cannot create protected ports VLANs when the switch is operating in a multiple VLAN mode.
- ❑ An untagged port of a protected ports VLAN can not be made an untagged member of another protected ports VLAN until it is first removed from its current VLAN assignment and returned to the Default\_VLAN.
- ❑ The switch must be set to the user-configured VLAN mode to support protected ports VLANs.



## Chapter 28

# MAC Address-based VLANs

---

This chapter contains overview information about MAC address-based VLANs. Sections in the chapter include:

- ❑ “Supported Platforms” on page 308
- ❑ “Overview” on page 309
- ❑ “Egress Ports” on page 310
- ❑ “VLANs That Span Switches” on page 313
- ❑ “VLAN Hierarchy” on page 315
- ❑ “Steps to Creating a MAC Address-based VLAN” on page 316
- ❑ “Guidelines” on page 317

## Supported Platforms

---

Refer to Table 87 and Table 88 for the AT-9400 Switches and the management interfaces that support MAC address-based VLANs.

Table 87. Support for the MAC Address-based VLANs

Switch	Supported
Layer 2+ Models	
AT-9408LC/SP	
AT-9424T/GB	
AT-9424T/SP	
Basic Layer 3 Models	
AT-9424T	Yes
AT-9424T/POE	Yes
AT-9424Ts	Yes
AT-9424Ts/XP	Yes
AT-9448T/SP	Yes
AT-9448Ts/XP	Yes
AT-9400Ts Stack	

Table 88. Management Interfaces for MAC Address-based VLANs

Switch or Stack	Standard Command Line	AlliedWare Plus Command Line	Menus	Web Browser
Stand-alone Switch	Yes		Yes	
AT-9400Ts Stack				

## Overview

---

As explained in “Overview” on page 271, VLANs are a means for creating independent LAN segments within a network and are typically employed to improve network performance and security.

The AT-S63 Management Software offers several different types of VLANs, including port-based, tagged, and protected ports. Membership in these VLANs is determined either by the port VLAN identifier (PVID) assigned to a port on a switch or, in the case of tagged traffic, by the VLAN identifier within the packets themselves.

This chapter describes VLANs that are based on the source MAC addresses of the end nodes that are connected to the switch. With a MAC address-based VLAN, only those nodes whose source MAC addresses have been entered as members of the VLAN can share and access the VLAN resources. This is in contrast to a port-based or tagged VLAN where any node that has access a switch port can join a VLAN as a member.

One of the principle advantages of this type of VLAN is that it can make it easier to manage network users that roam. These are users who access the network from different points at different times. The challenge for a network administrator is providing these users with the same resources regardless of the point at which they access the network. If you employed port-based or tagged VLANs for roaming users, you might have to reconfigure the VLANs, moving ports to and from different virtual LANs, so that the users always have access to the same network resources. But with a MAC address-based VLAN, the switch can assign a network user to the same VLAN and network resources regardless of the port from which the user accesses the network.

## Egress Ports

---

Implementing a MAC address-based VLAN involves more than entering the MAC addresses of the end nodes that are members of the VLAN. You must also designate the egress ports on the switch for the packets from the nodes. The egress ports define the limits of flooding of packets when a port receives a unicast packet with an unknown destination address (that is, an address that has not been learned by the MAC address table). Without knowing the egress ports, the switch would be forced to flood the packets on all switch ports, and that could result in a security violation where end nodes receive packets from other nodes that are in different VLANs.

Table 89 illustrates a simple example of the mapping of addresses to egress ports for a MAC address-based VLAN of 6 nodes. The example consists of four workstations, a printer, and a server. For instance, Workstation 1 is connected to port 1 on the switch and is mapped to egress ports 5 for the server and 6 for the printer.

Table 89. Mappings of MAC Addresses to Egress Ports Example

MAC address	End Node	Switch Egress Port
00:30:84:54:1A:45	Workstation 1 (Port 1)	5, 6
00:30:84:C3:5A:11	Workstation 2 (Port 2)	5, 6
00:30:84:22:67:17	Workstation 3 (Port 3)	5, 6
00:30:84:78:75:1C	Workstation 4 (Port 4)	5, 6
00:30:79:7A:11:10	Server (Port 5)	1-4
00:30:42:53:10:3A	Printer (Port 6)	1-4

Obviously, mapping source MAC addresses to egress ports can become cumbersome if you are dealing with a MAC address-based VLAN that encompasses a large number of ports and nodes. Fortunately, the egress ports of a VLAN are considered as a community and, as such, need only be designated as an egress port of one address in the VLAN to be considered an egress port of all the addresses.

For instance, referring to the previous example, if workstation 1 sends a packet containing an unknown destination MAC address, the switch does not flood the packet to just ports 5 and 6, even though those are the designated egress ports for packets from workstation 1. Rather, it floods it out all egress ports assigned to all the MAC addresses of the VLAN, except, of course, the port where the packet was received. In the example the switch would flood the packet out ports 2 through 6.

The community characteristic of egress ports relieves you from having to map each address to its corresponding egress port. You only need to be sure that all the egress ports in a MAC address-based VLAN are assigned to at least one address.

It is also important to note that a MAC address must be assigned at least one egress port to be considered a member of a MAC address-based VLAN. VLAN membership of packets from a source MAC address not assigned any egress ports is determined by the PVID of the port where the packets are received.

Because egress ports are considered as a community within a VLAN, you can simplify the mappings by assigning all of the egress ports to just one MAC address and, for the rest of the addresses, assigning just one port. This will make it easier to add or delete MAC addresses or egress ports from a VLAN. Here is how the example might look.

Table 90. Revised Example of Mappings of MAC Addresses to Egress Ports

MAC Address	End Node	Egress Port
00:30:84:54:1A:45	Workstation 1 (Port 1)	1-6
00:30:84:C3:5A:11	Workstation 2 (Port 2)	1
00:30:84:22:67:17	Workstation 3 (Port 3)	1
00:30:84:78:75:1C	Workstation 4 (Port 4)	1
00:30:79:7A:11:10	Server (Port 5)	1
00:30:42:53:10:3A	Printer (Port 6)	1

A switch can support more than one MAC-address VLAN at a time and a port can be an egress member of more than one VLAN. While this can prove useful in some situations, it can also result in VLAN leakage where the traffic of one VLAN crosses the boundary into other VLANs.

The problem arises in the case of unknown unicast traffic. If the switch receives a packet from a member of a MAC address-based VLAN with an unknown destination address, it floods the packet on all egress ports of the VLAN. If the VLAN contains a port that is also serving as an egress port of another VLAN, the node connected to the port receives the flooded packets, even if it does not belong to the same VLAN as the node that generated the packet.

Here's an example. Assume that Port 4 on a switch has been designated an egress port of three MAC address-based VLANs. Any unknown unicast traffic that the switch receives that belongs to any of the VLANs will be flooded out Port 4, even if there are no active members of that particular VLAN on the port. This means that whatever device is connected to the port receives the flooded traffic of all three VLANs.

If security is a major concern for your network, you might not want to assign a port as an egress port to more than one VLAN when planning your MAC address-based VLANs.

When a packet whose source MAC address is part of a MAC address-based VLAN arrives on a port, the switch performs one of the following actions:

- ❑ If the packet's destination MAC address is not in the MAC address table, the switch floods the packet out all egress ports of the VLAN, excluding the port where the packet was received.
- ❑ If the packet's destination MAC address is in the MAC address table and if the port where the address was learned is one of the VLAN's egress ports, the switch forwards the packet to the port.
- ❑ If the packet's destination MAC address is in the MAC address table but the port where the address was learned is not one of the VLAN's egress ports, the switch discards the packet.



## VLANs That Span Switches

To create a MAC address-based VLAN that spans switches, you must replicate the MAC addresses of the VLAN nodes on all the switches where the VLAN exists. The same MAC address-based VLAN on different switches must have the same list of MAC addresses.

Figure 39 illustrates an example of a MAC address-based VLAN that spans two AT-9400 Switches. The VLAN consists of three nodes on each switch. Table 91 on page 314 lists the details of the VLAN on the switches. Note that each VLAN contains the complete set of MAC addresses of all VLAN nodes along with the appropriate egress ports on the switches.

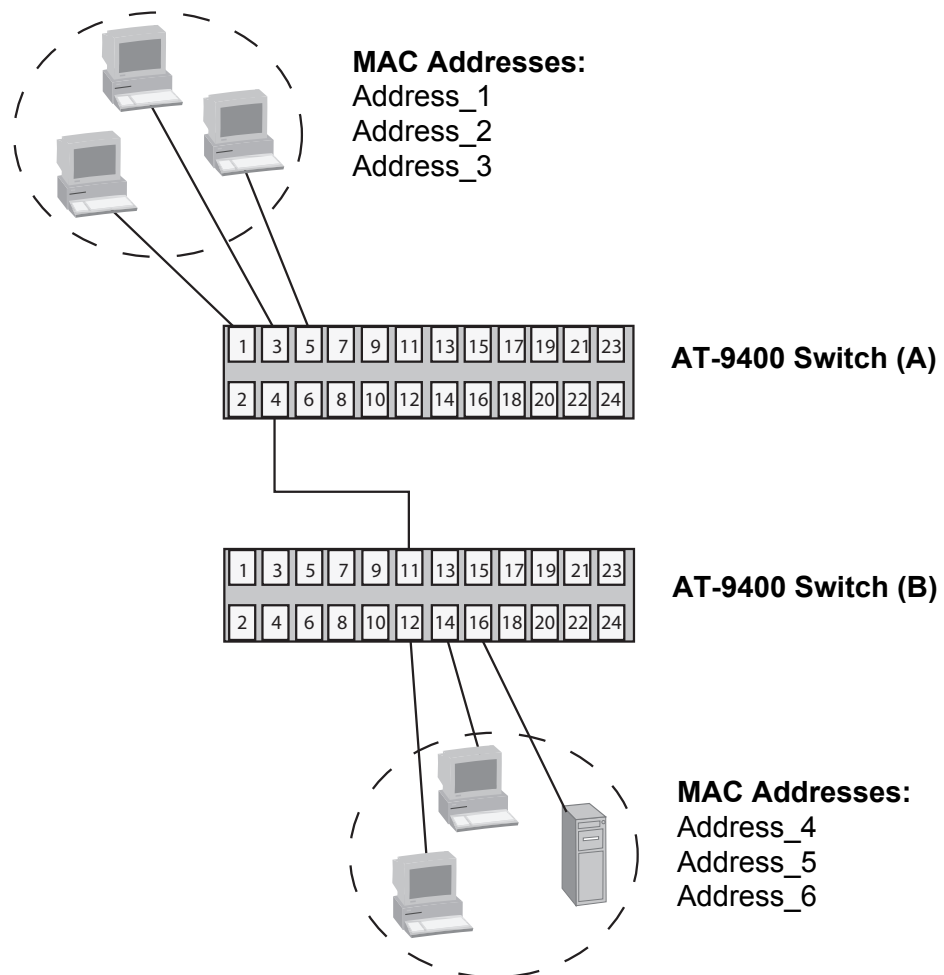

Figure 39. Example of a MAC Address-based VLAN Spanning Switches

Table 91. Example of a MAC Address-based VLAN Spanning Switches

Switch A		Switch B	
VLAN Name: Sales		VLAN Name: Sales	
MAC Address	Egress Ports	MAC Address	Egress Ports
Address_1	1,3,4,5	Address_1	11,12,14,16
Address_2	1	Address_2	11
Address_3	1	Address_3	11
Address_4	1	Address_4	11
Address_5	1	Address_5	11
Address_6	1	Address_6	11

## VLAN Hierarchy

---

The switch's management software employs a VLAN hierarchy when handling untagged packets that arrive on a port that is an egress port of a MAC address-based VLAN as well as an untagged port of a port-based VLAN. (A port can be a member of both types of VLANs at the same time.) The rule is that a MAC address-based VLAN takes precedence over that of a port-based VLAN.

When an untagged packet arrives on a port, the switch first compares the source MAC address of the packet against the MAC addresses of all the MAC address-based VLANs on the device. If there is a match, the switch considers the packet as a member of the corresponding MAC address-based VLAN and not the port-based VLAN, and forwards it out the egress ports defined for the corresponding MAC address-based VLAN.

If there is no match, the switch considers the packet as a member of the port-based VLAN and forwards the packet according to the PVID assigned to the port. For an explanation of a PVID, refer to "Port-based VLAN Overview" on page 273.

## Steps to Creating a MAC Address-based VLAN

---

Here are the three main steps to creating a MAC address-based VLAN:

1. Assign the VLAN a name and a VID. You must also set the VLAN type to MAC Based.
2. Assign the MAC addresses to the VLAN.
3. Add the egress ports to the MAC addresses.

The steps must be performed in this order.

## Guidelines

---

Follow these guidelines when implementing a MAC address-based VLAN:

- ❑ MAC address-based VLANs are not supported on the AT-9408LC/SP, AT-9424T/GB and AT-9424T/SP Switches.
- ❑ The switch can support up to a total of 4094 port-based, tagged, protected ports, and MAC address-based VLANs.
- ❑ The source nodes of this type of VLAN must send only untagged packets. A MAC address-based VLAN does not support tagged packets.
- ❑ The switch supports MAC address-based VLANs when operating in the user configured VLAN mode, which is the default setting for the switch. The switch must not be running a multiple VLAN mode.
- ❑ The egress ports of a VLAN are considered as a community. Assigning a port to one MAC address in a VLAN implicitly defines the port as an egress port of all the addresses in the same VLAN.
- ❑ A source MAC address must be assigned to at least one egress port to be considered part of a MAC address-based VLAN. Otherwise, VLAN membership is determined by the PVID of the port where the packets are received.
- ❑ A port can be an egress port of more than one MAC address-based VLAN.
- ❑ An egress port cannot be part of a port trunk.
- ❑ A MAC address can belong to only one MAC address-based VLAN at a time.
- ❑ A broadcast packet crosses VLAN boundaries when a port is an egress port of a MAC address-based VLAN and an untagged member of a port-based VLAN. Given that there is no way for the switch to determine the VLAN to which the broadcast packet belongs, it floods the packet on all ports of all affected VLANs.
- ❑ Entering a MAC address as part of a MAC address-based VLAN does not add the address to the MAC address table. The address appears in the MAC address table during the normal learning process of the switch.
- ❑ A MAC address-based VLAN is supported in an edge switch, where end nodes are connected directly to the switch, as well as in an intermediary switch, where the switch is connected to other Ethernet switches or hubs.
- ❑ The switch can support a total of 1024 MAC addresses in all its MAC address-based VLANs.
- ❑ A MAC address-based VLAN does not support multicast MAC addresses.

- ❑ Egress ports cannot be part of a static or LACP trunk.
- ❑ Since this type of VLAN does not support tagged packets, it is not suitable in environments where a network device, such as a network server, needs to be shared between multiple VLANs.
- ❑ Ports 49 and 50 on the AT-9448Ts/XP switch cannot be designated as egress ports of a MAC address-based VLAN.
- ❑ SFP ports 45 to 48 on the AT-9448T/SP switch cannot be designated as egress ports of a MAC address-based VLAN.

## Section VII

# Routing

---

This section has the following chapters:

- ❑ Chapter 29, “Internet Protocol Version 4 Packet Routing” on page 321
- ❑ Chapter 30, “BOOTP Relay Agent” on page 355
- ❑ Chapter 31, “Virtual Router Redundancy Protocol” on page 361





## Chapter 29

# Internet Protocol Version 4 Packet Routing

---

This chapter describes Internet Protocol version 4 (IPv4) packet routing on the AT-9400 Basic Layer 3 Switches. The chapter covers routing interfaces, static routes, and the Routing Information Protocol (RIP) versions 1 and 2. The sections in the chapter include:

- ❑ “Supported Platforms” on page 322
- ❑ “Overview” on page 324
- ❑ “Routing Interfaces” on page 326
- ❑ “Interface Names” on page 329
- ❑ “Static Routes” on page 330
- ❑ “Routing Information Protocol (RIP)” on page 332
- ❑ “Default Routes” on page 334
- ❑ “Equal-cost Multi-path (ECMP) Routing” on page 335
- ❑ “Routing Table” on page 337
- ❑ “Route Selection Process” on page 338
- ❑ “Address Resolution Protocol (ARP) Table” on page 339
- ❑ “Internet Control Message Protocol (ICMP)” on page 340
- ❑ “Routing Interfaces and Management Features” on page 342
- ❑ “Local Interface” on page 345
- ❑ “AT-9408LC/SP AT-9424T/GB, and AT-9424T/SP Switches” on page 346
- ❑ “Routing Command Example” on page 348
- ❑ “Non-routing Command Example” on page 352
- ❑ “Upgrading from AT-S63 Version 1.3.0 or Earlier” on page 354

## Supported Platforms

---

Refer to Table 92 and Table 93 for the AT-9400 Switches and the management interfaces that support the IPv4 packet routing feature.

Table 92. Support for IPv4 Packet Routing

Switch	Supported
Layer 2+ Models	
AT-9408LC/SP	One interface
AT-9424T/GB	One interface
AT-9424T/SP	One interface
Basic Layer 3 Models	
AT-9424T	Yes
AT-9424T/POE	Yes
AT-9424Ts	Yes
AT-9424Ts/XP	Yes
AT-9448T/SP	Yes
AT-9448Ts/XP	Yes
AT-9400Ts Stack	Yes

Table 93. Management Interfaces for IPv4 Packet Routing

Switch or Stack	Standard Command Line	AlliedWare Plus Command Line	Menus	Web Browser
Stand-alone Switch	Yes	Yes	Yes	
AT-9400Ts Stack	Yes	Yes		

Here are a few things you need to know about the supported platforms and the management interfaces for the IP packet routing feature:

- The Layer 2+ models do not support IP packet routing. However, you can create one IP routing interface to assign the switches an IP configuration, which is required by some management features. For further information, refer to “Routing Interfaces and Management

Features” on page 342 and “AT-9408LC/SP AT-9424T/GB, and AT-9424T/SP Switches” on page 346.

- ❑ AT-9400Ts Stacks support static routes but not RIP.
- ❑ You can use the menus on a stand-alone switch to configure the routing interfaces, but not static routes or RIP. To configure all of the feature’s components, you must use the command line.

## Overview

---

This section contains an overview of the IPv4 routing feature on the AT-9400 Switch. It begins with an explanation of the following available routing methods:

- ❑ Routing interfaces
- ❑ Static routes
- ❑ RIP version 1 and 2

A routing interface is a logical connection to a local network or subnet for the purpose of routing IPv4 packets. Interfaces route packets between the local networks and subnets directly connected to the switch and are independent of static routes and RIP. In some limited network topologies where there are no remote networks or subnets, you may be able to meet the routing requirements of the IPv4 packets on your network with just routing interfaces. This feature is explained in “Routing Interfaces” on page 326.

In order for the switch to route packets to a remote destination (i.e., a network or subnet not directly connected to the switch), there must be a route to the destination in the routing table of the switch. A route consists of the IP address of the remote destination and the IP address of the next hop to reaching the destination.

One method for specifying a route to a remote destination is to enter it manually. This type of route is referred to as a static route. A static route contains the IP addresses of the remote destination and the next hop. You can also create a static route for packets with an unknown destination network or subnet. This type of route is referred to as a default route. For background information on static routes and the default route, refer to “Static Routes” on page 330.

A switch can automatically learn routes to remote destinations with the Routing Information Protocol (RIP). This protocol allows the routers of a network to automatically share their routes by broadcasting their routing tables to each other. The AT-9400 Switch supports versions 1 and 2 of this routing protocol. This feature is explained in “Routing Information Protocol (RIP)” on page 332.

This overview also contains an explanation of the role played by interfaces with some of the management features of the switch, and how those features are dependent on there being at least one interface on the switch. A few examples of the management functions include uploading and downloading files to the switch using a TFTP server and the enhanced stacking feature. For information, refer to “Routing Interfaces and Management Features” on page 342.

At the end of this overview are two examples that illustrate the sequence of commands to implementing the features described in this chapter. You can refer there to see how the commands are used in practice. The sections are “Routing Command Example” on page 348 and “Non-routing Command Example” on page 352.

In the following discussions, unless stated otherwise the term “remote destination” refers to a network or subnet that is not directly connected to the switch.

## Routing Interfaces

---

The IPv4 packet routing feature on the switch is built on the foundation of the routing interface. An interface functions as a logical connection to a subnet that allows the egress and ingress of IPv4 packets to the subnet from other local and remote networks, subnets, and nodes.

Interfaces are an independent routing function. They are not dependent on static routes or RIP to pass IPv4 traffic among themselves on a switch. A switch automatically begins to route IPv4 packets among its local subnets as soon as two or more interfaces have been defined on the device.

In order for a switch to route IPv4 traffic among its local subnets, it must have a routing interface on each subnet. You create an interface by assigning it a unique IP address of the subnet and indicating the VLAN where the subnet resides.

Interfaces also function as anchor points for static routes. A static route defines the next hop to a remote destination. To create a static route to a remote destination, you add it to the interface on the switch where the next hop to the remote destination is located.

Interfaces also act as anchor points for RIP. You can add RIP to the interfaces so that the switch automatically learns routes to remote destinations by sharing its routing information with the neighboring routers.

In some limited network topologies, you might be able to meet the routing requirements of the IPv4 packets of your network with just routing interfaces. This would assume, of course, that the switch is directly connected to all of the networks or subnets of your network and that there are no remote destinations that would require static routes or RIP.

Here are several other items to note concerning routing interfaces on the AT-9400 Switch:

- ❑ The switch can support up to 512 interfaces at one time, which means it can route the IPv4 traffic on up to 512 local subnets and networks.
- ❑ A single VLAN on a switch can contain up to sixteen interfaces.
- ❑ The AT-9408LC/SP, AT-9424T/GB, and AT-9424T/SP switches do not support the IPv4 packet routing feature. However, you can create one routing interface on the switches to serve as an IP configuration for the device. For more information, refer to “Routing Interfaces and Management Features” on page 342 and “AT-9408LC/SP AT-9424T/GB, and AT-9424T/SP Switches” on page 346.
- ❑ The commands for managing interfaces are `ADD IP INTERFACE`, `DELETE IP INTERFACE`, and `SET IP INTERFACE`.

---

**Note**

Routing interfaces can be configured from either the command line interface or the menu interface.

---

The following subsections describe the three main components of a routing interface:

- ❑ VLAN ID (VID)
- ❑ Interface number
- ❑ IP address and subnet mask

**VLAN ID (VID)**

An interface must be assigned to the VLAN on the switch where its network or subnet resides. The VLAN is identified by its VLAN identification (VID) number or VLAN name. The sequence of operations is to create the VLAN first and then the routing interface. Creating the interface before the VLAN is not permitted.

A VLAN can have more than one interface in circumstances where a virtual LAN contains more than one subnet. The maximum number is sixteen routing interfaces per VLAN, making sixteen the maximum number of subnets you can have in a VLAN and still support packet routing on all of them.

**Interface Numbers**

An interface must be assigned an interface number in the range of 0 to 15. This range corresponds to the maximum number of interfaces permitted in a VLAN. Interfaces in different VLANs on the same switch can have the same interface number, but interfaces in the same VLAN must have different numbers.

For instance, if a switch has four local subnets and each is in a different VLAN, all of the interfaces could have the same interface number, such as 0. However, if two or more of the subnets reside in the same VLAN, the routing interfaces for the subnets in the VLAN must be assigned different interface numbers.

Interface numbers are only used for interface identification when there is more than one subnet and routing interface in a VLAN. Consequently, the sequence in which the interface numbers are used is not important.

**IP Address and Subnet Mask**

An interface must be a member of the local network or subnet where it will function as the logical connection for routing IPv4 packets. As such, it must be assigned a unique IP address and a subnet mask appropriate to the network or subnet.

The IP address and subnet mask of an interface can be assigned manually or supplied by a DHCP or BOOTP server on the network. When a VLAN contains more than one interface, only one of the interfaces can obtain its IP address from a DHCP or BOOTP server. The IP addresses of

the other interfaces in the same VLAN must be assigned manually. For example, if there are four interfaces and each of their respective subnets resided in a separate VLAN, then each interface can obtain its IP address and subnet mask from a DHCP or BOOTP server. However, if the four subnets share the same VLAN, only one interface can obtain its IP address from a DHCP or BOOTP server. The other three must be configured manually.



## Interface Names

---

Many of the IPv4 routing commands have a parameter for an interface name. An interface name consists of a VLAN and an interface number, separated by a dash. The VLAN is designated by “vlan” followed by the VLAN identification number (VID) or the VLAN name.

Here are several examples. The name for a interface in a VLAN with the VID of 7 and an interface number of 0 is:

```
vlan7-0
```

The name for an interface in a VLAN with the VID of 28 and an interface number of 2 is:

```
vlan28-2
```

Here is an example of an interface name that uses the VLAN name instead of the VID to identify the VLAN. The interface is part of the Sales VLAN and has an interface number of 5. Note that a dash separates “vlan” from the VLAN name.

```
vlan-sales-5
```

The following is an example of a command that uses an interface name. The example uses the ADD IP INTERFACE command to create a new interface for a subnet in a VLAN with a VID of 28. The interface is assigned an interface number of 0, an IP address of 149.44.22.22, and a subnet mask of 255.255.255.0:

```
add ip interface=vlan28-0 ipaddress=149.44.22.22 mask  
255.255.255.0
```

This command is identical to the previous command, except it identifies the VLAN by its name, Production:

```
add ip interface=vlan-Production-0 ipaddress=149.44.22.22  
mask 255.255.255.0
```

## Static Routes

---

In order for the switch to route an IPv4 packet to a remote network or subnet, there must be a route to the destination in the routing table of the switch. The route must consist of the IP address of the remote destination and the IP address of the next hop to reaching the destination.

One type of route to a remote destination is referred to as a static route. You create static routes by manually entering them into the routing table. Static routes are never deleted from the routing table by the switch, even when they are inactive.

When you create a static route, the switch's management software automatically adds it to the interface that is a part of the same subnet as the next hop of the route. Consequently, before you can create a static route, the switch must have a routing interface that is a member of the same subnet as the next hop of the route.

For example, assume a switch supported four subnets with four interfaces named VLAN4-0, VLAN11-0, VLAN12-0, and VLAN12-1. If you created a static route to a remote destination that had as its next hop an IP address in the subnet of the VLAN4-0 interface, the switch would automatically add the route to the VLAN4-0 interface.

A new static route immediately becomes available for all of the interfaces on a switch to use for routing packets to the remote subnet. For example, referring to the previous example, a static route added to the VLAN4-0 interface would be available to all the other interfaces on the same switch.

The switch can store up to 1024 static routes.

A static route is functional as soon as it is added to an interface and cannot be disabled. If you do not want a switch to use a static route, you must delete the route from the table.

Static routes have a parameter called the metric that is a measurement of the cost of the switch when it forwards packets to the remote destination specified in the static route. The metric or cost is simply the hop count. The default setting for a static route is one hop. The value can be set higher to make a static route more costly. Networks, subnets, and nodes directly connected to a router have a hop count of 0.

Static routes also have a parameter for assigning a preference value. The switch uses this value to select the active routes when there are multiple static or dynamic routes in the routing table to the same remote destination. The range for the preference parameter is 0 to 65535. The lower the value, the higher the preference. The default value for a static route is 60.

The commands for managing static routes are ADD IP ROUTE, DELETE IP ROUTE, and SET IP ROUTE.

## Routing Information Protocol (RIP)

---

A switch can automatically learn routes to remote destinations by sharing the contents of its routing table with its neighboring routers in the network with the Routing Information Protocol (RIP) versions 1 and 2.

RIP is a fairly simple distance vector routing protocol that defines networks based in how many hops they are from the switch, just as with static routes. A network that is more than fifteen hops away (one hop is one link) is considered as unreachable and is not included in the routing table.

RIP version 2 permits the addition of subnet masks and next hop information in RIP updates. This allows the use of different sized subnet masks on different subnets within the same network.

RIP broadcasts are automatically activated when the protocol is added to a routing interface on the switch. An interface sends RIP packets to the RIP multicast address 224.0.0.9 when sending version 2 packets or uses the broadcast address when sending out version 1 packets.

A route is propagated by RIP if its status at the physical level is active. An active route has at least active one port in the VLAN. RIP does not propagate an inactive route where there are no active ports in the VLAN.

RIP can be added to a maximum of 100 interfaces on a switch and the route table can store up to 1024 dynamic routes.

Since the interfaces on a switch can route packets among the local subnets without the presence of RIP or static routes, the routing protocol is only necessary if the switch is to learn remote destinations by sharing the switch's routing table with the neighboring routers, and you choose not to specify the routes manually with static routes.

You add RIP to the routing interfaces where there are neighboring routers to remote destinations. You do not need to add RIP to interfaces where there are no neighboring routers.

A route learned by RIP is immediately added to the routing table, where it becomes available to all the interfaces on the switch.

When you add RIP to an interface, you can specify the type of RIP packets the routing protocol is to send and receive. The AT-9400 Switch can send either version 1 or 2 packets and accept either or both versions.

Version 2 supports the addition of a password of up to sixteen alphanumeric characters to protect routers and their tables from incorporating bogus routing updates. The switch adds the password into the routing table when it broadcasts the contents of the table to its neighboring routing devices, which check the password prior to updating their tables.

---

**Note**

A RIP version 2 password is sent in plaintext. The AT-S63 Management Software does not support encrypted RIP passwords.

---

The switch transmits its routing table every thirty seconds from those interfaces that have RIP. This interval is not adjustable on the switch. The entire table is sent with the following exceptions:

- Dynamic RIP routes that fall under the split horizon rule.
- Inactive interface routes where there are no active ports in the VLAN.

---

**Note**

The AT-S63 Management Software does not support the RIP holddown and flush timers.

---

The commands for managing RIP are ADD IP RIP, DELETE IP RIP, and SET IP RIP.

---

**Note**

RIP must be configured from the command line interface. The menus and web browser interfaces do not support this feature.

---

The AT-9400 Switch supports the following RIP functions:

- Split horizon
- Split horizon with poison reverse
- Autosummarization of routes

## Default Routes

---

A default route is a “match all” destination entry in the routing table. The switch uses it to route packets whose remote destinations are not in the routing table. Rather than discard the packets, the switch sends them to the next hop specified in the default route.

A default route has a destination IP address of 0.0.0.0 and no subnet mask. A default route can be entered manually in the form of a static route or learned dynamically through RIP. A switch can have multiple default routes.

## Equal-cost Multi-path (ECMP) Routing

---

When there are multiple routes in the routing table to the same remote destinations, ECMP enables the switch to use the different routes to forward traffic. This can improve network performance by increasing the available bandwidth for the traffic flows, and also provide for route redundancy.

The routing table permits up to 32 routes to the same remote destination, with up to eight of the routes as active at one time. The routes can be all static routes, RIP routes, or a combination of the two. Routes to the same destination must have different next hops. The routing table will not permit two entries to the same remote destination with the same next hop.

When the routing table contains eight or less routes to the same destination, all the routes can be active and available to route packets. The distribution of the traffic among the active routes is controlled through a hash that combines the packet source and destination IP addresses to select a route for packets from a source node. The traffic from a specific source and destined for a specific remote destination is assigned a route and all traffic to that remote destination from that source is forwarded using that route. The assignment of a route does not change except if the path is lost (for instance, the status of an interface changes from up to down), in which case its traffic is redirected to one of the remaining routes.

When there are more than eight routes in the table to the same destination, the active routes are selected by preference value, metric value, and age, in that order. The routes with the eight lowest preference values are selected as the active routes. Where routes have the same preference value, selection is based on the lowest metric values. Otherwise, the selections are based on when the routes were added to the routing table, with older routes given preference over newer routes.

Those routes not selected as active routes are placed in a standby mode. The selection of the active destination routes by the switch is dynamic and can change as routes are added and deleted from the routing table, and when they change status. For instance, if a new static or RIP route is added to the routing table when there are already eight active routes to the same destination, the new route will replace an existing active route if it has a lower preference value, forcing one of the active routes to change to the standby mode.

Furthermore, an interface must be physically up with at least one active port in the VLAN for any of its routes to be considered as available for use. If an interface is down, meaning there are no active ports in the VLAN, the routes of the interface are considered inactive and are not assigned any traffic. For example, if there are eight routes to the same destination, but two of the routes reside in an interface that is down, those routes are not used, leaving six available routes.

ECMP also applies to default routes. This enables the switch to store up to 32 default routes with up to eight of the routes active at one time.

The ECMP feature can be enabled and disabled on the switch. The operating status of ECMP does not affect the switch's ability to store multiple routes to the same destination in its routing table. Rather, it controls how many of the available routes the switch uses to route packets to the same remote destination. When ECMP is enabled, the default setting, the switch can use multiple routes to route packets to the same remote destination, as explained above. When ECMP is disabled, the switch selects only one route, based on preference value, metric value, or age, to route packets to a remote subnet even when there are multiple routes to the subnet.

A local subnet or directly connected network of a switch is usually represented just once in the routing table by its routing interface. However, in some situations a local subnet might have several routes to it if it is also remotely reachable through other routing interfaces on the switch via other routers. One of the routes would be the subnet's routing interface and the others could be RIP or static routes. Here, even if ECMP is enabled, the switch uses only the routing interface to route packets to the local subnet, because the routing interface is always the preferred route to a local subnet. Any RIP or static routes to the local subnet are held in the standby mode for fail-over protection. They are only used when the status of the routing interface to the local subnet is down.



## Routing Table

---

The switch maintains its routing information in a table of routes that tells the switch how to find a local or remote destination. Each route is uniquely identified in the table by its IP address, network mask, next hop, protocol, and routing interface.

When the switch receives an IPv4 packet, it scans the routing table to find the most specific route to the destination on an “up” interface where there is at least one active port in the VLAN. If the switch does not find a direct route to the remote destination and no default route exists, the switch discards the packet and sends an ICMP message to that effect back to the source.

The switch transmits its routing table every thirty seconds from those interfaces that have RIP. The RIP timer is not adjustable. The switch also transmits its routing table and resets the timer to zero whenever there is a change to the table to ensure that the neighboring routers are immediately informed of updates to the table.

Dynamic RIP routes are removed from the table when they are not kept up to date (refreshed) by the neighboring routers. The metric of a route that is not refreshed is increased to 16 to indicate an unreachable network. If the route is not updated after 180 seconds, it is deleted from the table.

The maximum storage capacity of the routing table in the AT-9400 Switch is:

- 512 interface routes
- 1024 static routes
- 1024 RIP routes

## Route Selection Process

---

Here is the route selection process the switch goes through when routing packets to a destination:

- ❑ If there is only one route to a destination, forward the packets using the route.
- ❑ If there is more than one route to a destination, select the route with the lowest preference value.
- ❑ If there is more than one route with the lowest preference value, select the route with the lowest metric value.
- ❑ If there is more than one route with the lowest metric value, select the route with the most specific netmask.
- ❑ If there is more than one route with the most specific netmask and if Equal-Cost Multipath (ECMP) routing is enabled, distribute the packets equally across the routes. The default setting for ECMP is enabled.
- ❑ If there is more than one route with the most specific netmask and if Equal-Cost Multipath (ECMP) routing is disabled, select the first remaining route.

## Address Resolution Protocol (ARP) Table

---

The switch maintains an ARP table of IP addresses and the matching Ethernet MAC addresses. It refers to the table when routing packets to determine the destination MAC addresses of the nodes, as well as interfaces and ports from where the nodes are reached.

The ARP table can store both static and dynamic entries. Static entries are entries you add yourself. This type of entry is never removed by the switch from the ARP table, even when the corresponding nodes are inactive.

Dynamic entries are entries that the switch learns on its own. Dynamic entries of inactive nodes are periodically removed from the table to prevent the table from filling with entries of inactive nodes.

The switch learns addresses by sending out ARP requests. It generates an ARP request whenever it receives a packet that needs to be routed across a subnet, but lacks the destination MAC address in its ARP table. The switch, after receiving the ARP response from the destination node, adds the IP address and MAC address of the node to its ARP table and begins to route packets to the device. It should be noted that until it receives a response to its ARP request, the switch discards all routed packets intended to a destination node.

The switch can also learn addresses when it is the destination of an ARP request from another node, such as when it is pinged by a management station. The switch adds the source IP address and MAC address in the request from the node to the table when it responds to the ARP request.

Dynamic ARP entries are aged from the table according to the ARP cache timeout value to protect the table from filling with entries for hosts which are no longer active. The default setting for the timeout value is 150 seconds. This value is adjustable with the SET IP ARP TIMEOUT command. Static ARP entries are not aged and are retained in the table even when the nodes are inactive.

The commands for managing the ARP table are ADD IP ARP, DELETE IP ARP, SET IP ARP, SET IP ARP TIMEOUT, and SHOW IP ARP.

---

**Note**

The switch does not support Proxy ARP.

---

The storage capacity of the ARP table in the AT-9400 Switch is:

- 1024 static entries
- 1024 dynamic entries

## Internet Control Message Protocol (ICMP)

---

ICMP allows routers to send error and control messages to other routers or hosts. It provides the communication between IP software on one system and IP software on another. The switch implements the ICMP functions listed in Table 94.

Table 94. ICMP Messages Implemented on the AT-9400 Switch

ICMP Packet (Type)	Switch Response
Echo reply (0)	This is used to implement the “ping” command common to most UNIX and TCP implementations. The switch sends out an “Echo reply” packet in response to an “Echo request.”
Destination unreachable (3)	This message is sent out when the switch drops a packet because it did not have a route to the destination.
Source Quench (4)	The switch will send a “Source Quench” if it must drop a packet due to limited internal resources. This could be because the source was sending data too fast to be forwarded.
Redirect (5)	The switch will issue a “redirect” packet to inform a local host that its target is located on the same LAN (no routing is required) or when it detects a host using a non-optimal route (usually because a link has failed or changed its status).
Echo request (8)	This is related to (1) and results in an “echo reply” packet being sent. The switch can also generate an “echo request” packet as a result of the PING command.

Table 94. ICMP Messages Implemented on the AT-9400 Switch

<b>ICMP Packet (Type)</b>	<b>Switch Response</b>
Time to Live Exceeded (11)	If the TTL field in a packet falls to zero the switch will send a “Time to live exceeded” packet. This could occur if a route was excessively long or if too many hops were in the path.

## Routing Interfaces and Management Features

---

Routing interfaces are primarily intended for the IPv4 packet routing feature. There are, however, a number of management functions that rely on the presence of at least one routing interface on the switch to operate properly. The switch uses the IP address of an interface as its source address when performing the management function. The management functions are listed here:

- ❑ Accessing network servers
- ❑ Enhanced stacking
- ❑ Remote Telnet, SSH, and web browser management sessions
- ❑ Pinging a remote device
- ❑ Accessing DHCP or BOOTP servers

### Accessing Network Servers

A local subnet on the switch must have an interface if the device is using the subnet to access any of the following types of network servers:

- ❑ SNTP server for setting the switch's date and time.
- ❑ RADIUS or TACACS+ authentication server for manager access accounts and 802.1x port-based network access control.
- ❑ Syslog server for storing events from the switch's event logs.
- ❑ TFTP server for uploading and downloading files to the switch.

The switch uses the IP address of the interface as its source address when communicating with a network server. Without a routing interface on the subnet, the switch will not have a source IP address to include in its packets. For example, in order to set its date and time using an SNTP server, the switch must have a routing interface on the local subnet from where it is reaching the server.

The servers can be located on different routing interfaces on the switch. For instance, the switch can access an SNTP server through one interface and a RADIUS authentication server from another. This differs from some of the earlier versions of the AT-S63 Management Software where all the servers had to be members of what was referred to as the "management VLAN."

If you intend to use the IPv4 routing feature of the switch and assign routing interfaces to all the local subnets and networks on a switch, this requirement should not be an issue. However, if you choose not to use the routing function and so not create interfaces or you have an AT-9400 Switch that only supports one interface, some planning will be necessary in order to use these features. At a minimum, you must create one routing interface on the switch and plan your network so that the switch can access the servers from the subnet of the interface.

As an example, assume you decided not to implement the IPv4 routing feature on a switch that had four local subnets, but you wanted the switch to send its events to a syslog server and have access to a RADIUS authentication server. Assume also that you wanted to use a TFTP server to upload and download files to the device. This would require that you plan your network so that the switch could reach the syslog, RADIUS, and TFTP servers from the same local subnet on the unit. You would also need to assign an interface to the subnet. The switch, having only one interface, would not route IPv4 packets among its local subnets and directly connected networks, but would use the interface's IP address to communicate with the servers.

## **Enhanced Stacking**

The enhanced stacking feature simplifies the task of managing the Allied Telesis switches in your network by allowing you to easily transition among the switches in a stack during a management session.

The switches of an enhanced stack must be interconnected by a common VLAN and the VLAN must be assigned a routing interface on each of the switches. Furthermore, the routing interface in the common VLAN on the master switch must be designated as the local interface, as described in "Local Interface" on page 345.

There is an important difference between the need for interfaces with enhanced stacking versus network servers, as explained in the previous subsection. Network servers can be reached by the switch through different interfaces in different subnets, simultaneously. In contrast, the switches of an enhanced stack must share a common VLAN and subnet.

For background information and guidelines on the enhanced stacking feature, refer to Chapter 3, "Enhanced Stacking" on page 77.

## **Remote Telnet, SSH, and Web Browser Management Sessions**

Remote Telnet and SSH management sessions of the switch must be transacted through a subnet that has a routing interface on the switch. Furthermore, the interface must be designated as the switch's local interface. Only workstations that can reach the switch through the subnet of the local interface can manage the unit. This rule applies to isolated devices (that is, switches that are not a part of an enhanced stack) and a master switch of an enhanced stack. This does not apply to a slave switches of an enhanced stack.

For background information and guidelines on remote management, refer to the *Starting an AT-S63 Management Session Guide*.

**Pinging a Remote Device**

This function is used to validate the existence of an active path between the switch and another network node. The switch can ping a device if it has a routing interface on the local subnet from where the device is reached. In previous versions of the AT-S63 Management Software the device to be pinged had to be reached through the management VLAN of the switch. This restriction no longer applies. A remote device can be pinged from any subnet of the switch that has an interface.

**Accessing DHCP or BOOTP Servers**

You can use a DHCP or BOOTP server to assign IP addresses to the interfaces of a switch by activating the client on the interfaces.



## Local Interface

---

The local interface is used with the enhanced stacking feature. It is also used with remote management of a switch with a Telnet or SSH client, or a web browser. The local interface does the following:

- ❑ With an enhanced stack, it designates on the master switch the common VLAN and subnet that interconnects the switches of the stack. The master switch uses the local interface to send out its broadcast packets when searching for the other switches in a stack.
- ❑ With remote management, it designates the VLAN and subnet from where the remote management workstation will access the switch. The switch uses the local interface to watch for the management packets from the remote workstation and to send packets back to the remote station.

For example, assume you wanted to remotely manage a switch that had four subnets and four interfaces named VLAN4-0, VLAN11-0, VLAN12-0, and VLAN12-1, and the remote workstation was reaching the switch through the subnet of the VLAN11-0 interface. You would need to designate the VLAN11-0 interface as the local interface on the unit.

A switch can have only one local interface.

For background information on remote management of the switch, refer to the *Starting an AT-S63 Management Session Guide*. For background information on enhanced stacking, refer to Chapter 3, “Enhanced Stacking” on page 77.

## AT-9408LC/SP AT-9424T/GB, and AT-9424T/SP Switches

---

The AT-9408LC/SP, AT-9424T/GB, and AT-9424T/SP Switches do not support the IPv4 packet routing feature. They do, however, support a limited version of some of the features.

### Local Interface

You can create one routing interface to provide support for those management features that require the switch to have an IP address. Furthermore, the interface can be designated as the local interface so that the switch can function as the master switch of an enhanced stack or for remote Telnet, SSH, or web browser management. For further information, refer to “Routing Interfaces and Management Features” on page 342.

### ARP Table

These switches also have an ARP table with a maximum capacity of ten ARP entries. The table and entries are used by the AT-S63 Management Software when it performs a management function that requires it to communicate with another device on the network. An example would be if you instructed the switch to ping another network device or download a new AT-S63 image file or configuration file from a TFTP server.

The value of the ARP table is that it eliminates the need of the switch to issue unnecessary ARP broadcast packets when performing some management functions. This can improve the switch’s response time as well as reduce the number of broadcast packets on your network.

There are two types of entries. One type is permanent. There is only one permanent entry and it is used by the switch for internal diagnostics. It can never be removed from the table.

The other type is a temporary entry, of which there can be up to nine. The switch adds a temporary entry whenever its management software interacts with another network device during a management function. When you enter a management command that contains an IP address not in the table, the switch sends out an ARP broadcast packet. When the remote device responds with its MAC address, the switch adds the device’s IP address and MAC address as a new temporary entry to the table.

A temporary entry remains in the table only while active. An entry remains active so long as it is periodically used by the switch for management functions. If an entry is inactive for a defined period of time known as the ARP cache timeout, it is automatically removed from the table. To adjust this value, refer to the SET IP ARP TIMEOUT command. The default is 150 seconds. If the table becomes full, the management software continues to add new entries by deleting the oldest entries.

---

**Note**

The AT-9408LC/SP, AT-9424T/GB, and AT-9424T/SP Switches do not use the ARP table to move packets through the switching matrix. They refer to the table only when they perform a management function requiring them to communicate with another network node.

---

**Default Gateway**

The default gateway specifies the IP address of an interface on a neighboring router. The switch's management software uses this address as the next hop to reaching a remote network device, such as a remote Telnet, SSH, or web browser management workstation or a syslog server, when the switch's interface and the remote device are on different subnets.

As an example, assume you wanted to manage the switch from a remote management workstation on a different subnet than the local interface, and needed the switch to access a RADIUS authentication server also on a different subnet. Here, you would need to define a default gateway on the switch so that the unit would know the next hop to reaching the remote workstation and the RADIUS server.

The default gateway is only used for management functions, such as communicating with a remote management workstation or sending events to a syslog server. The default gateway is not used during the normal Layer 2 switching of packets among the switch ports and, as such, is not necessary for normal operations of the device.

You define the default gateway by creating a default route on the switch. As explained in "Static Routes" on page 330, this type of route does not specify a destination address. Rather, it simply defines the IP address of the next hop, which becomes the default gateway for the switch.

The IP address of the next hop of the default route must be of the same subnet as the switch's interface.

## Routing Command Example

---

This section contains an example of the IPv4 routing feature. It illustrates the sequence of commands to implementing the feature. To make the example easier to explain, some of the command options are not mentioned and the default values are used instead.

---

### Note

This example does not apply to the AT-9408LC/SP, AT-9424T/GB, and AT-9424T/SP switches, which do not support the packet routing feature. For an example of how to assign an IP address to those switches, refer to “Non-routing Command Example” on page 352.

---

This example has the following sections:

- ❑ “Creating the VLANs” on page 349
- ❑ “Creating the Routing Interfaces” on page 349
- ❑ “Adding a Static Route and Default Route” on page 350
- ❑ “Adding RIP” on page 351
- ❑ “Selecting the Local Interface” on page 351

This example assumes an AT-9448T/SP Switch with four local subnets. Two subnets will reside in their own VLANs and two will share a VLAN. The table below lists the relevant information.

Table 95. IPv4 Routing Example

Company Department	VLAN Name	VID	Subnet IP Address	Subnet Mask	Ports <sup>a</sup>
Sales	Sales	4	149.35.67.0	255.255.255.0	U - 1-11 T - 50
Production	Production	5	149.35.68.0	255.255.255.0	U - 12-20 T - 50
Engineering Group 1	Engineering	11	149.35.69.0	255.255.255.0	U - 21 - 40 T - 50
Engineering Group 2			149.35.70.0	255.255.255.0	

a. U - untagged ports; T - tagged ports

## Creating the VLANs

The first step is to create the VLANs for the local subnets on the switch. The VLANs must be created before the routing interfaces. The following command creates a VLAN for the Sales department with a VID of 4 and the appropriate ports:

```
create vlan=sales vid=4 untaggedport=1-11 taggedport=50
```

The following commands create the Production and Engineering VLANs:

```
create vlan=Production vid=5 untaggedport=12-20
taggedport=50
```

```
create vlan=Engineering vid=11 untaggedport=21-40
taggedport=50
```

Note that even though there are four local subnets in the example, there are only three VLANs because two of the subnets will share a VLAN.

For further information on this command, refer to the CREATE VLAN command.

## Creating the Routing Interfaces

Now that the VLANs are created, you can add the routing interfaces for the individual subnets. There are four local subnets in the example, so there will need to be four interfaces to support routing on all of them.

The following command creates the routing interface for the Sales subnet. The interface name is based on the VID of the VLAN, which is 4, and an interface number, in this case 0. The interface is assigned the unique IP address 149.35.67.11 and a subnet mask to make it a member of its corresponding subnet.

```
add ip interface=vlan4-0 ipaddress=149.35.67.11
netmask=255.255.255.0
```

These commands create the interfaces for the remaining subnets:

```
add ip interface=vlan5-0 ipaddress=149.35.68.24
netmask=255.255.255.0
```

```
add ip interface=vlan11-0 ipaddress=149.35.69.23
netmask=255.255.255.0
```

```
add ip interface=vlan11-1 ipaddress=149.35.70.45
netmask=255.255.255.0
```

The Engineering VLAN (VID 11) has two interfaces for its two subnets. Each interface is given a different interface number, 0 and 1, to distinguish between them.

At this point, the switch begins to route IPv4 packets among the local subnets.

For further information on this command, refer to the ADD IP INTERFACE

command.

## Adding a Static Route and Default Route

Building on our example, assume you decided to manually enter a route to a remote subnet as a static route. The command for creating a static route is ADD IP ROUTE. Here is the basic information for defining a static route:

- The IP address of the remote destination.
- The subnet mask of the remote destination.
- The IP address of the next hop.
- The routing interface on the switch where the next hop is located. This piece of information is optional because the switch can automatically determine the appropriate interface from the IP address of the next hop. The IP addresses of the next hop of a static route and the interface where the hop is located must be members of the same subnet.

Let's assume you wanted to add a static route to a remote subnet with the IP address 149.35.22.0 and a mask of 255.255.255.0. Let's also assume that the IP address of the next hop is 149.35.70.26, making it part of the subnet of the VLAN11-1 interface. Consequently, the static route must be added to that interface, though you do not need to specify it in the command. Here is the command for adding the static route:

```
add ip route=149.35.22.0 nexthop=149.35.70.26
mask=255.255.255.0
```

A static route becomes active as soon as it is defined and is available to all of the interfaces on the switch.

Now assume that you want to create a default route for when the switch receives a packet with a destination address to a network or subnet for which it does not have a route. All you need to know for a default route is the IP address of the next hop for the packets. For this example, assume that the IP address of the next hop will be 149.35.68.12. This locates the next hop on the VLAN5-0 interface. Here is the command for creating the default route:

```
add ip route=0.0.0.0 nexthop=149.35.68.12
```

A default route does not have a subnet mask. Note also that the appropriate routing interface for the next hop, in this example VLAN5-0, is also not defined because, as with other static routes, specifying the interface is optional.

## Adding RIP

Rather than adding the static routes to remote destinations, or perhaps to augment them, you decide that the switch should learn routes by exchanging its route table with its routing neighbors using RIP. To implement RIP, you add it to the routing interfaces where routing neighbors are located. The command for adding RIP to an interface is `ADD IP RIP`.

For the purpose of this example, assume the routing neighbors of the switch are located on the VLAN5-0 and VLAN11-1 interfaces. The following commands add RIP to the interfaces and configure the routing protocol to send only version 2 packets, but accept packets of either version 1 or 2. In both cases, RIP is running without a password.

```
add ip rip interface=vlan5-0 send=rip2 receive=both
authentication=none
```

```
add ip rip interface=vlan11-1 send=rip2 receive=both
authentication=none
```

You could, if you wanted, add RIP to the other interfaces. But since, in our example, those interfaces do not have links to other RIP routers, they would not learn any routes.

## Selecting the Local Interface

This last part of the example designates a local interface. This step is necessary on a master switch of an enhanced stack to designate the common VLAN of the switches in the stack. This is also necessary if you want to manage the device from a remote management workstation with a Telnet or SSH client, or a web browser.

Let's assume you plan to remotely manage the switch from a management workstation that reaches the device through the subnet in the Sales VLAN, which has the interface name is VLAN4-0. Here is the command to designate that interface as the local interface on the switch:

```
set ip local interface=vlan4-0
```

To start a remote management session on the switch, you use the IP address of the local interface as the switch's address. In the example, the switch's address would be 149.35.67.11 because that happens to be the IP address of the VLAN4-0 interface, which is the local interface.

## Non-routing Command Example

---

This example illustrates how to assign an IP address to a switch by creating just one interface. This example is appropriate in cases where you want to implement the management functions described in “Routing Interfaces and Management Features” on page 342 but without IPv4 packet routing. This section is also appropriate for the AT-9400 Layer 2+ Switches, which do not support packet routing.

The first step is to select the VLAN and subnet on the switch for the interface. The appropriate VLAN for the master switch of an enhanced stack is the common VLAN of the switches in the stack. The appropriate VLAN for remote management or for remote access to a network server is the VLAN where the remote device is located.

Let’s assume for the purposes of this example that the switch will be remotely managed from a Telnet, SSH, or web browser management workstation on the network. Consequently, the appropriate VLAN would be the VLAN on the switch where the remote management workstation is located. Assume that the VID of the VLAN is 12 and the IP address of the subnet of the VLAN is 149.44.55.0 with a subnet mask of 255.255.255.0.

The following command assigns an interface to the VLAN. It identifies the VLAN by its VID of 12 and assigns it the interface number 0. The interface is given the IP address 149.44.55.22 to make it a member of the subnet:

```
add ip interface=vlan12-0 ipaddress=149.44.55.22
netmask=255.255.255.0
```

In order to manage the switch remotely, the interface must be designated as the local interface so that the management software monitors the subnet for management packets. Here is the command for designating the interface as the local interface:

```
set ip local interface=vlan12-0
```

As the final part of the example, assume that the management software on the switch must communicate with a network device, such as management workstation, syslog server, or RADIUS server, that is not a member of the same subnet as the interface. For this, you need to define a default route. The route will specify the next hop to reaching the remote subnet. The switch will use the default route whenever it needs to send a management packet to a remote network device that resides on a different subnet than its local interface.

The next hop in the route must specify the IP address of a routing interface on a router in the network. Furthermore, the IP address of the routing interface must be a member of the same subnet as the interface on the switch.



The following command creates a default route for the example and specifies the next hop as 149.44.55.6:

```
add ip route=0.0.0.0 nexthop=149.44.55.6
```

## Upgrading from AT-S63 Version 1.3.0 or Earlier

---

When the AT-9400 Switch running AT-S63 version 1.3.0 or earlier is upgraded to the latest version of the management software, the switch automatically creates a routing interface that preserves the previous IP configuration of the unit. If the switch had a static address, the interface is assigned the same address. If the address was supplied by a DHCP or BOOTP server, the DHCP or BOOTP client on the interface is activated. The interface is given the interface number 0 and assigned to the preexisting management VLAN. Furthermore, the interface is designated as the local interface of the switch.

For example, a switch with the static IP address 149.55.55.55, subnet mask 255.255.255.0, and a management VLAN with a VID of 12 will have, after the upgrade, a routing interface with the name VLAN12-0 and the same static IP address and subnet mask.

By retaining the IP configuration, those management functions (e.g., remote Telnet management, syslog client, and RADIUS client) that were operating before the upgrade will continue to operate after the unit is upgraded to the newest version of the management software. Without this feature, you would have to restore the switch's IP configuration by manually creating a routing interface.

If the switch does not have an IP address and the DHCP and BOOTP clients are not activated, the upgrade process does not create a routing interface.

## Chapter 30

# BOOTP Relay Agent

---

This chapter has the following sections:

- ❑ “Supported Platforms” on page 356
- ❑ “Overview” on page 357
- ❑ “Guidelines” on page 359

## Supported Platforms

---

Refer to Table 96 and Table 97 for the AT-9400 Switches and the management interfaces that support the BOOTP relay agent.

Table 96. Support for the BOOTP Relay Agent

Switch	Supported
Layer 2+ Models	
AT-9408LC/SP	
AT-9424T/GB	
AT-9424T/SP	
Basic Layer 3 Models	
AT-9424T	Yes
AT-9424T/POE	Yes
AT-9424Ts	Yes
AT-9424Ts/XP	Yes
AT-9448T/SP	Yes
AT-9448Ts/XP	Yes
AT-9400Ts Stack	Yes

Table 97. Management Interfaces for the BOOTP Relay Agent

Switch or Stack	Standard Command Line	AlliedWare Plus Command Line	Menus	Web Browser
Stand-alone Switch	Yes			
AT-9400Ts Stack	Yes			

## Overview

---

The AT-S63 Management Software comes with a BOOTP relay agent for relaying BOOTP messages between clients and DHCP or BOOTP servers.

When a client sends a BOOTP request to a DHCP or BOOTP server for an IP configuration, it transmits the request as a broadcast packet because it does not know the IP address of the server. This can present a problem when a client and server reside on different subnets, because broadcast packets do not cross subnet boundaries. One possible solution is to have a DHCP or BOOTP server on each subnet where there are clients, though this could be problematic if there happen to be a lot of subnets. Another solution is to use a BOOTP relay agent, which transfers client requests across subnet boundaries.

The BOOTP relay agent does more than simply forward BOOTP requests from clients to servers. It modifies the requests so that, from the perspective of the server, it becomes the originator of the request. The responses from the servers are directed to the agent, which sends the messages on to the clients as either broadcast or unicast packets, depending on the requirements of the clients.

To implement BOOTP relay on the switch, you need to be familiar with routing interfaces, which route packets between different local subnets on the switch in the IPv4 packet routing feature. Each routing interface functions as the BOOTP relay agent for the clients in its subnet, forwarding BOOTP requests from the clients and responses from the servers.

If you will be using the IPv4 packet routing feature on all the local subnets, then, by default, all of the clients will have access to a BOOTP relay agent because each subnet will have a routing interface. However, if IPv4 packet routing will be limited to some but not all the local subnets of the switch, then only those BOOTP requests from clients on a subnet with a routing interface will be forwarded to a BOOTP relay agent.

Here is an overview of the process. When a routing interface receives a BOOTP request with a value of 0.0.0.0 in the gateway (giaddr) field in the packet, it assumes the request originated from a client on its subnet. In response, it replaces the value in the field with its IP address and forwards the packet on to the server. If more than one IP address of DHCP or BOOTP servers are specified on the switch, the interface sends the same request to each server. If the client and server reside on the same subnet, the routing interface does not forward the request.

If an interface receives a BOOTP request with a non-zero value in the gateway field, it assumes the client who originated the request resides on another subnet, and so routes the request as a unicast packet without any change, other than incrementing the hop count.

A routing interface that receives a BOOTP reply from a server inspects the broadcast flag field in the packet to determine whether the client, in its original request to the server, set this flag to signal that the response must be sent as a broadcast datagram. Some older nodes have this dependency. If the flag is not set, the routing interface forwards the packet to the originating client as a unicast packet. If the flag is set, the packet is forwarded as a broadcast by the interface.

You configure the BOOTP relay agent on the switch by specifying the IP address of the BOOTP server on your network with the `ADD BOOTP RELAY` command. You can enter up to eight BOOTP or DHCP servers. The IP addresses apply to all the routing interfaces on the switch. BOOTP requests are forwarded to all the specified servers, simultaneously.

You activate the BOOTP relay agent on the switch with the `ENABLE BOOTP RELAY` command. As soon as the agent is enabled the routing interfaces begin to forward BOOTP requests from the clients. Activating the agent applies to all routing interfaces on the switch. You cannot activate the agent on some interfaces and not on others. The default setting for the agent on the switch is disabled.

To view the status of the agent and the IP addresses of the servers, use the `SHOW BOOTP RELAY` command.

## Guidelines

---

These guidelines apply to the BOOTP relay agent:

- ❑ A routing interface functions as the BOOTP relay agent for the local clients in its subnet.
- ❑ You can specify up to eight DHCP or BOOTP servers.
- ❑ The TTL for BOOTP request relay packets is preset on the AT-9400 Switch to 4. It cannot be changed. Routing interfaces discard BOOTP requests when the TTL is decremented to zero (i.e., after 4 hops).
- ❑ Because both BOOTP and DHCP use BOOTP messages, the BOOTP relay agents can relay both their packets.





## Chapter 31

# Virtual Router Redundancy Protocol

---

The chapter has the following sections:

- ❑ “Supported Platforms” on page 362
- ❑ “Overview” on page 363
- ❑ “Master Switch” on page 364
- ❑ “Backup Switches” on page 365
- ❑ “Interface Monitoring” on page 366
- ❑ “Port Monitoring” on page 367
- ❑ “VRRP on the Switch” on page 368

## Supported Platforms

---

Refer to Table 98 and Table 99 for the AT-9400 Switches and the management interfaces that support the Virtual Router Redundancy Protocol.

Table 98. Support for the Virtual Router Redundancy Protocol

Switch	Supported
Layer 2+ Models	
AT-9408LC/SP	
AT-9424T/GB	
AT-9424T/SP	
Basic Layer 3 Models	
AT-9424T	Yes
AT-9424T/POE	Yes
AT-9424Ts	Yes
AT-9424Ts/XP	Yes
AT-9448T/SP	Yes
AT-9448Ts/XP	Yes
AT-9400Ts Stack	

Table 99. Management Interfaces for the Virtual Router Redundancy Protocol

Switch or Stack	Standard Command Line	AlliedWare Plus Command Line	Menus	Web Browser
Stand-alone Switch	Yes			
AT-9400Ts Stack				

## Overview

---

This chapter describes the Virtual Router Redundancy Protocol (VRRP) of the AT-9400 Basic Layer 3 Switches.

One of the functions that switches provide to the hosts of a LAN is to act as gateways. The local hosts use the gateways to communicate with the hosts on the WAN. The local hosts are assigned static routes that define which gateway switch to use as the next hop to reach the WAN. However, if a statically configured first hop switch fails, the hosts on the LAN will not be able to communicate with the WAN. If there are a large number of hosts, it can be time consuming and cumbersome if you have to reconfigure the static routes on all of the affected hosts.

The Virtual Router Redundancy Protocol provides a solution to the problem. It combines two or more physical switches into a logical grouping called a *virtual router* (VR). The physical switches in the virtual router operate together to provide a single logical gateway for hosts on the LAN so that if one gateway fails, the hosts will still be able to communicate with the WAN.

## Master Switch

---

The virtual router has a virtual MAC address known by all the switches that participate in the virtual router. The virtual MAC address is derived from the *virtual router identifier*, which is a user-defined value from 1 to 255. All the hosts on the LAN are configured with an IP address to use as the first hop. This IP address is typically owned by the preferred switch in the group of switches that constitute the virtual router. When available, this switch performs the duties of the virtual router, and is referred to as the *master*. The switch that owns the IP address associated with the virtual router is referred to as the *preferred master*. When a virtual router is configured so that none of the participating switches owns the IP address, the virtual router has no preferred master.

When a switch takes the role of master for a virtual router, it does the following:

- ❑ Responds to ARP packets for the IP addresses associated with the virtual router. The ARP response contains the virtual MAC address of the virtual router so that the hosts on the LAN associate the virtual MAC address with their configured first hop IP address.
- ❑ Forwards packets with a destination link layer MAC address equal to the virtual router MAC address.
- ❑ Accepts packets addressed to the IP address(es) associated with the virtual router, but only if it actually owns the address(es).
- ❑ Broadcasts advertisement packets at regular intervals (at the specified advertisement interval) to inform backup switches that it is still acting as the master switch.

In accordance with the RFC standard, a user does not receive a response to ping or Telnet packets sent to the VR address unless the switch owns this address.

## Backup Switches

---

All the other switches participating in the virtual router are designated as backup switches. A switch can be part of several different virtual routers on one LAN, provided that all the virtual routers have different virtual router identifiers.

When a switch functions as a backup for a virtual router, it does the following:

- ❑ Receives advertisement packets from the master switch and checks that the information contained in them is consistent with their own configuration, ignoring and discarding advertisement packets that do not match.
- ❑ Assumes the role of master switch for the virtual router if an advertisement packet is not received for a given period of time (the “master-down” period), based on the specified advertisement interval. The “master-down” time is approximately three times the advertisement interval.
- ❑ Assumes the role of master switch if it receives an advertisement packet from another switch with a lower priority than its own, if preempt mode is on.

When the master switch fails, the backup switch assumes control and starts processing traffic.

If a backup switch is about to assume the role of master of the virtual router because it has not received an advertisement for the “master-down” period, it first checks the operational status of the interface to which the virtual router is attached. If the interface is down, it does not enter the master state. Instead, it stays in the backup state and checks the interface again after another “master-down” period, assuming that it does not receive an advertisement during that time.

## Interface Monitoring

---

The virtual router can monitor certain interfaces to change the priority of switches if the master switch loses its connection to the outside world. This is known as *interface monitoring*. Interface monitoring reduces the priority of the switch when an important interface connection is lost. The reduction in priority causes a backup switch with a higher priority to take over as the master switch and restore connectivity.

If a master switch loses its connection to the outside world, the connection to the LAN is not affected. Advertisement packets are still sent by the master and received by the backup switches, but the master is unable to send data to other networks because its connection to the outside world has been lost.

## Port Monitoring

---

*Port monitoring* is the process of detecting the failure of ports that are part of a VLAN that a virtual router is running over. If a port fails or is disabled, the VRRP priority is reduced by the stepvalue or by an amount that reflects the proportion of the VLAN's ports that are out of service. If the switch is the master and a backup switch has a higher priority, the backup switch preempts the master and becomes the new master.

Note the following about port monitoring:

- ❑ You can delete an IP interface if it is a monitored interface, because VRRP is only monitoring the state of the interface and does not require that the interface have an IP address.
- ❑ A VLAN cannot be destroyed if it is a monitored interface of a VRRP. To destroy a VLAN, you must first destroy the monitored interface.

## VRRP on the Switch

---

VRRP is disabled by default. When a virtual router is created on the switch, it is enabled by default, but the VRRP module must be enabled before it is operational. The VRRP module or a specific virtual router can be enabled or disabled afterwards by using the `ENABLE VRRP` and `DISABLE VRRP` commands.

A virtual router must be created on at least two switches before it operates correctly. To create a virtual router for an IP address over an Ethernet interface, so that the switch participates in the virtual router, use the `CREATE VRRP` command.

To destroy a virtual router on the LAN, it must be removed from all participating switches. To remove a virtual router so that the switch no longer participates in it, use the `DESTROY VRRP` command.

If the switch in the master role for the virtual router becomes unavailable, the master role is taken by the switch with the highest priority amongst the available switches. The priority is a value from 1 to 255, with a default of 100. The highest value of 255 is reserved for the switch that owns the virtual router's IP address. The new master takes over all the responsibilities of the original master. Hosts on the LAN can continue sending packets to the same virtual MAC address with which they associate the configured first hop IP address, even though the switch that owns the IP address is not currently available. When the preferred switch that owns the IP address becomes available again, it resumes the role of master.

By default, when a switch becomes available with a higher priority than the master, it takes over as master. This is referred to as *preempt* mode and can be set on or off. Even with preempt mode off, the switch that owns the IP address always becomes the master when available. If two switches are configured with the same priority, the one with the highest IP address has higher priority. Preempt mode must be the same for all switches in the virtual router. Set the priority and preempt mode when you create the virtual router; modify it later by using the `SET VRRP` command.

The frequency with which the master sends advertisement packets must be set to the same value for all switches in the virtual router. The default advertisement interval of 1 second is recommended for most networks. This is set with the `ADINTERVAL` parameter in the `CREATE VRRP` and `SET VRRP` commands.

Each of the switches in the virtual router can be configured for plaintext authentication or none. No authentication is suitable when there is minimal security risk, and the configuration is so simple (for example, two switches on a LAN) that there is little chance of configuration errors. Plaintext password authentication protects against accidental misconfiguration and



prevents a switch from inadvertently backing up another switch. The authentication type and, in the case of plaintext authentication, the password, must be the same for all switches in the virtual router. By default, the virtual router has no authentication. Authentication is set with the AUTHENTICATION and PASSWORD parameters in the CREATE VRRP and SET VRRP commands.

In order for the security level of the LAN to be maintained, each switch in the virtual router must have at least the minimum allowable level of security.

A virtual router is always created to back up one primary IP address on all the switches in the virtual router. Up to 16 secondary IP addresses can be backed up by the same virtual router, as long as they are compatible with the IP address and mask associated with the Ethernet interface over which the IP address of the virtual router is operating. Such secondary addresses must be added to all the switches in the virtual router. The virtual router's primary IP address cannot be deleted. To add or remove secondary IP addresses, use the ADD VRRP IPADDRESS and DELETE VRRP IPADDRESS commands.

A monitored interface is one that the virtual router is dependent on for full operation. VRRP is informed if the operational status of the interface changes. If the interface is not operational, the switch's priority is reduced. To add or remove a monitored interface to or from a virtual router, use the ADD VRRP MONITOREDINTERFACE and DELETE VRRP MONITOREDINTERFACE commands.

It is important that all switches involved in a virtual router be configured with the same values for the following:

- VRRP virtual router identifier
- IP address
- advertisement interval
- preempt mode
- authentication type
- password

Inconsistent configuration causes advertisement packets to be rejected and the virtual router cannot perform properly.



## Section VIII

# Port Security

---

The chapters in this section contain overview information on the port security features of the AT-9400 Switch. The chapters include:

- ❑ Chapter 32, “MAC Address-based Port Security” on page 373
- ❑ Chapter 33, “802.1x Port-based Network Access Control” on page 379



## Chapter 32

# MAC Address-based Port Security

---

The sections in this chapter include:

- ❑ “Supported Platforms” on page 374
- ❑ “Overview” on page 375
- ❑ “Invalid Frames and Intrusion Actions” on page 377
- ❑ “Guidelines” on page 378

## Supported Platforms

---

Refer to Table 100 and Table 101 for the AT-9400 Switches and the management interfaces that support MAC address-based port security.

Table 100. Support for MAC Address-based Port Security

Switch	Supported
Layer 2+ Models	
AT-9408LC/SP	Yes
AT-9424T/GB	Yes
AT-9424T/SP	Yes
Basic Layer 3 Models	
AT-9424T	Yes
AT-9424T/POE	Yes
AT-9424Ts	Yes
AT-9424Ts/XP	Yes
AT-9448T/SP	Yes
AT-9448Ts/XP	Yes
AT-9400Ts Stack	Yes

Table 101. Management Interfaces for MAC Address-based Port Security

Switch or Stack	Standard Command Line	AlliedWare Plus Command Line	Menus	Web Browser
Stand-alone Switch	Yes	Yes	Yes	Yes
AT-9400Ts Stack	Yes	Yes		

**Note**

This port security feature is not supported on GBIC, SFP, or XFP modules.

---

## Overview

---

You can use this feature to enhance the security of your network by controlling which end nodes can forward frames through the switch, and so prevent unauthorized individuals from accessing your network. It uses a frame's source MAC address to determine whether the switch should forward a frame or discard it. The source address is the MAC address of the end node that sent the frame.

There are four levels of port security:

- Automatic
- Limited
- Secured
- Locked

You set port security on a per port basis. Only one security level can be active on a port at a time.

### **Automatic**

The Automatic security mode disables port security on a port. This is the default security level for a port.

### **Limited**

The Limited security level allows you to specify the maximum number of dynamic MAC addresses a port can learn. The port forwards only packets of learned source MAC addresses and discards ingress frames with unknown source MAC addresses.

When the Limited security mode is initially activated on a port, all dynamic MAC addresses learned by the port are deleted from the MAC address table. The port then begins to learn new addresses, up to the maximum allowed. After the port has learned its maximum number of addresses, it does not learn any new addresses, even when end nodes are inactive.

A dynamic MAC address learned on a port operating in the Limited security mode never times out from the MAC address table, even when the corresponding end node is inactive.

Static MAC addresses are retained by the port and are not included in the count of maximum dynamic addresses. You can continue to add static MAC addresses to a port operating with this security level, even after the port has already learned its maximum number of dynamic MAC addresses. A switch port can have up to a total of 255 dynamic and static MAC addresses.

**Secured** This security level uses only static MAC addresses assigned to a port to forward frames. Consequently, only those end nodes whose MAC addresses are entered as static addresses are able to forward frames through a port. Dynamic MAC addresses already learned on a port are discarded from the MAC table and no new dynamic addresses are added. Any ingress frames having a source MAC address not entered as a static address on a port are discarded.

After activating this security level, you must enter the static MAC addresses of the end nodes that are to forward frames through the port.

**Locked** A port set to this security level immediately stops learning new dynamic MAC addresses and forwards frames using the dynamic MAC addresses it has already learned and any static MAC addresses assigned to it. Ingress frames with an unknown MAC address are discarded. Dynamic MAC addresses already learned by a port prior to the activation of this security level never time out from the MAC address table, even when the corresponding end nodes are inactive.

You can continue to add new static MAC addresses to a port operating under this security level.

---

**Note**

For background information on MAC addresses and aging time, refer to “Overview” on page 94.

---



## Invalid Frames and Intrusion Actions

---

When a port receives an invalid frame, it has to select an *intrusion action*, which defines the port's response to the packet. But before defining the intrusion actions, it helps to understand what constitutes an invalid frame. This differs for each security level, as explained here:

- ❑ Limited Security Level - An invalid frame for this security level is an ingress frame with a source MAC address not already learned by a port after the port had reached its maximum number of dynamic MAC addresses, or that was not assigned to the port as a static address.
- ❑ Secured Security Level - An invalid frame for this security level is an ingress frame with a source MAC address that was not entered as a static address on the port.
- ❑ Locked - An invalid frame for this security level is an ingress frame with a source MAC address that the port has not already learned or that was not assigned as a static address.

Intrusion action defines what a port does when it receives an invalid frame. For a port operating under either the Secured or Locked security mode, the intrusion action is always the same. The port discards the frame.

But with the Limited security mode you can specify the intrusion action. Here are the options:

- ❑ Discard the invalid frame.
- ❑ Discard the invalid frame and send an SNMP trap. (SNMP must be enabled on the switch for the trap to be sent.)
- ❑ Discard the invalid frame, send an SNMP trap, and disable the port.

## Guidelines

---

The following guidelines apply to MAC address-based port security:

- ❑ The filtering of a packet occurs on the ingress port, not on the egress port.
- ❑ You cannot use MAC address port security and 802.1x port-based access control on the same port. To configure a port as an Authenticator or Supplicant in 802.1x port-based access control, you must set its MAC address security level to Automatic, which is the default setting.
- ❑ This type of port security is not supported on optional GBIC, SFP, or XFP modules.
- ❑ All of a port's static MAC addresses are deleted when its security level is changed from Locked to any of the other three security levels.

## Chapter 33

# 802.1x Port-based Network Access Control

---

The sections in this chapter are:

- ❑ “Supported Platforms” on page 380
- ❑ “Overview” on page 381
- ❑ “Authentication Process” on page 383
- ❑ “Port Roles” on page 384
- ❑ “Authenticator Ports with Single and Multiple Supplicants” on page 387
- ❑ “Supplicant and VLAN Associations” on page 394
- ❑ “Guest VLAN” on page 396
- ❑ “RADIUS Accounting” on page 397
- ❑ “General Steps” on page 398
- ❑ “Guidelines” on page 399

## Supported Platforms

Refer to Table 102 and Table 103 for the AT-9400 Switches and the management interfaces that support 802.1x port-based network access control.

Table 102. Support for 802.1x Port-based Network Access Control

Switch	Supported
Layer 2+ Models	
AT-9408LC/SP	Yes
AT-9424T/GB	Yes
AT-9424T/SP	Yes
Basic Layer 3 Models	
AT-9424T	Yes
AT-9424T/POE	Yes
AT-9424Ts	Yes
AT-9424Ts/XP	Yes
AT-9448T/SP	Yes
AT-9448Ts/XP	Yes
AT-9400Ts Stack	Yes

Table 103. Management Interfaces for 802.1x Port-based Network Access Control

Switch or Stack	Standard Command Line	AlliedWare Plus Command Line	Menus	Web Browser
Stand-alone Switch	Yes	Yes	Yes	Yes
AT-9400Ts Stack	Yes	Yes		Yes

## Overview

---

The AT-S63 Management Software has several different methods for protecting your network and its resources from unauthorized access. For instance, Chapter 32, “MAC Address-based Port Security” on page 373, explains how you can restrict network access using the MAC addresses of the end nodes of your network.

This chapter explains yet another way. This method, referred to as 802.1x port-based network access control, uses the RADIUS protocol to control who can send traffic through and receive traffic from a switch port. The switch does not allow an end node to send or receive traffic through a port until the user of the node has been authenticated by a RADIUS server.

The benefit of this type of network security is obvious. You can use it to prevent unauthorized individuals from connecting a computer to a switch port or using an unattended workstation to access your network resources. Only those users designated as valid network users on the RADIUS server will be permitted to use the switch to access the network.

This port security method uses the RADIUS authentication protocol. The AT-S63 Management Software is shipped with RADIUS client software. If you have already read Chapter 38, “TACACS+ and RADIUS Protocols” on page 447, then you know that you can use the RADIUS client software on the switch, along with a RADIUS server on your network, to also create new manager accounts that control who can manage and change the AT-S63 parameter on the switch.

---

**Note**

RADIUS with Extensible Authentication Protocol (EAP) extensions is the only supported authentication protocol for 802.1x port-based network access control. This feature is not supported with the TACACS+ authentication protocol. The switch supports only one authentication protocol at a time. Consequently, if you want to implement 802.1 Port-based Network Access Control and also create new manager accounts as explained in Chapter 38, “TACACS+ and RADIUS Protocols” on page 447, you must use the RADIUS protocol.

---

Following are several terms to keep in mind when you use this feature.

- ❑ **Supplicant** - A supplicant is an end user or end node that wants to access the network through a switch port. A supplicant is also referred to as a client.
- ❑ **Authenticator** - The authenticator is a port on the switch that prohibits network access by a supplicant until the supplicant has been validated by the RADIUS server.

- ❑ Authentication server - The authentication server is the network device that has the RADIUS server software. This is the device that does the actual authenticating of the supplicants.

The AT-9400 Switch does not authenticate any of the supplicants connected to its ports. It's function is to act as an intermediary between a supplicant and the authentication server during the authentication process.

## Authentication Process

---

Below is a brief overview of the authentication process that occurs between a supplicant, authenticator, and authentication server. For further details, refer to the IEEE 802.1x standard.

- ❑ Either the authenticator (that is, a switch port) or the supplicant initiates an authentication message exchange. The switch initiates an exchange when it detects a change in the status of a port (such as when the port transitions from no link to valid link), or if it receives a packet on the port with a source MAC address not in the MAC address table.
- ❑ An authenticator starts the exchange by sending an EAP-Request/Identity packet. A supplicant starts the exchange with an EAPOL-Start packet, to which the authenticator responds with a EAP-Request/Identity packet.
- ❑ The supplicant responds with an EAP-Response/Identity packet to the authentication server via the authenticator.
- ❑ The authentication server responds with an EAP-Request packet to the supplicant via the authenticator.
- ❑ The supplicant responds with an EAP-Response/MD5 packet containing a username and password.
- ❑ The authentication server sends either an EAP-Success packet or EAP-Reject packet to the supplicant.
- ❑ Upon successful authorization of the supplicant by the authentication server, the switch adds the supplicant's MAC address to the MAC address as an authorized address and begins forwarding network traffic to and from the port.
- ❑ When the supplicant sends an EAPOL-Logoff message, the switch removes the supplicant's MAC address from the MAC address table, preventing the supplicant from sending or receiving any further traffic from the port.

## Port Roles

---

Part of the task of implementing this feature is specifying the roles of the ports on the switch. A port can have one of three roles:

- None
- Authenticator
- Supplicant

### None Role

A switch port in the None role does not participate in port-based access control. Any device can connect to the port and send traffic through it and receive traffic from it without being validated. This port setting is appropriate if no validation is required for the network device connected to the port. This is the default setting for the switch ports.

---

#### Note

Because a RADIUS authentication server cannot authenticate itself, it must communicate with the switch through a port that is set to the None role.

---

### Authenticator Role

Placing a switch port in the authenticator role activates port access control on the port. A port in the role of authenticator does not forward network traffic to or from the end node until the client has been authenticated by a RADIUS server.

Determining whether a switch port should be set to the authenticator role is straightforward. You should set a port on a switch to the authenticator role if you want the user of the end node connected to the port to be authenticated before being permitted to use the network.

#### Authentication Modes

The AT-9400 Switch supports two authentication modes on an authenticator port.

- 802.1x username/password combination

In this authentication mode, each supplicant connected to an authenticator port must be assigned a unique username and password combination on the RADIUS server. A supplicant must provide the information either manually or automatically when initially passing traffic through an authenticator port and during reauthentications. The 802.1x client software on the supplicant either prompts the user for the necessary information or provides the information automatically.



Assigning unique username and password combinations to your network users and requiring the users to provide the information when they initially send traffic through the switch can enhance network security by limiting network access to only those supplicants who have been assigned valid combinations. Another advantage is that the authentication is not tied to any specific computer or node. An end user can log on from any system and still be verified by the RADIUS server as a valid user of the switch and network.

This authentication method requires 802.1x client software on the supplicant nodes.

❑ **MAC address-based authentication**

An alternative method is to use the MAC address of a node as the username and password combination for the device. The client is not prompted for this information. Rather, the switch extracts the source MAC address from the initial frames received from a supplicant and automatically sends the MAC address as both the username and password of the supplicant to the RADIUS server for authentication.

The advantage to this approach is that the supplicant need not have 802.1x client software. The disadvantage is that because the client is not prompted for a username and password combination, it does not guard against an unauthorized individual from gaining access to the network through an unattended network node or by counterfeiting a valid network MAC address.

## **Operational Settings**

A port in the authenticator role can have one of three possible operational settings:

- ❑ **Auto** - Activates port-based authentication. The port begins in the unauthorized state, forwarding only EAPOL frames and discarding all other traffic. The authentication process begins when the link state of the port changes or the port receives an EAPOL-Start packet from a supplicant. The switch requests the identity of the client and begins relaying authentication messages between the client and the RADIUS authentication server. After the supplicant is validated by the RADIUS server, the port begins forwarding all traffic to and from the supplicant. This is the default setting for an authenticator port.
- ❑ **Force-authorized** - Disables IEEE 802.1X port-based authentication and automatically places the port in the authorized state without any authentication exchange required. The port transmits and receives normal traffic without authenticating the client.

**Note**

A supplicant connected to an authenticator port set to force-authorized must have 802.1x client software if the port's authenticator mode is 802.1x. Though the force-authorized setting prevents an authentication exchange, the supplicant must still have the client software to forward traffic through the port.

- ❑ Force-unauthorized - Causes the port to remain in the unauthorized state, ignoring all attempts by the supplicant to authenticate. The port forwards EAPOL frames, but discards all other traffic. This setting is analogous to disabling a port.

As mentioned earlier, the switch itself does not authenticate the user names and passwords from the clients. That function is performed by the authentication server and the RADIUS server software. The switch acts as an intermediary for the authentication server by denying access to the network by the client until the client has been validated by the authentication server.

**Supplicant Role**

A switch port in the supplicant role acts as a client. The port assumes it must log in by providing a valid user name and password to whatever device it is connected to, typically another switch port.

Figure 40 illustrates the port role. Port 11 on switch B has been set to the supplicant role. Now, whenever switch B is power cycled or reset and initiates a link with switch A, it must log on by providing a username and password. (You enter this information when you configure the port for the supplicant role.)

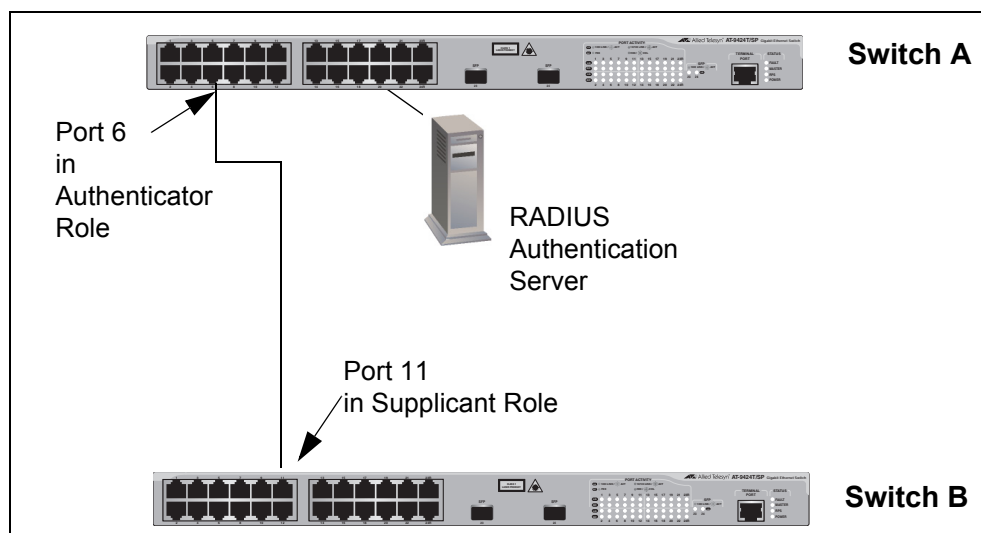

Figure 40. Example of the Supplicant Role

## Authenticator Ports with Single and Multiple Supplicants

---

An authenticator port has two operating modes. The modes relate to the number of clients using the port and, in situations where an authenticator port is supporting more than one client, whether just one client or all the clients must log on to use the switch port.

The operating modes are:

- Single
- Multiple

### Single Operating Mode

The Single operating mode is used in two situations. The first is when an authenticator port supports only one client. In this scenario, the switch allows only one client to log on and use the port.

You can also use the Single mode when an authenticator port supports more than one client, but where only one client needs to log on in order for all clients to use the port. This configuration can be useful in situations where you want to add 802.1x Port-based Network Access Control to a switch port that is supporting multiple clients, but want to avoid having to create individual accounts for all the clients on the RADIUS server.

This is referred to as “piggy-backing.” After one client has successfully logged, the port permits the other clients to piggy-back onto the initial client’s log on, allowing all clients to forward packets through the port.

To implement this configuration, you have to set the operating mode of an authenticator port to Single and also toggle the piggy-back mode feature. When piggy-back is disabled, only one client is allowed to log on and use the port. When this feature is enabled, an unlimited number of clients can use the port after one client has successfully logged on.

Note, however, that should the client who accomplished the initial log on fail to periodically reauthenticate or log out, the switch port reverts to the unauthenticated state. It bars all further traffic to and from all the clients on the port, until the initial client or another client logs on.

Here are several examples that illustrate the Single operating mode and the piggy-back mode of an authenticator port. In Figure 41 on page 388, an authenticator port on a switch, in this case port 6, is connected to a single client. The authenticator port’s operating mode is set to Single and the piggy-back feature is disabled so that only one client can use the port at any one time.

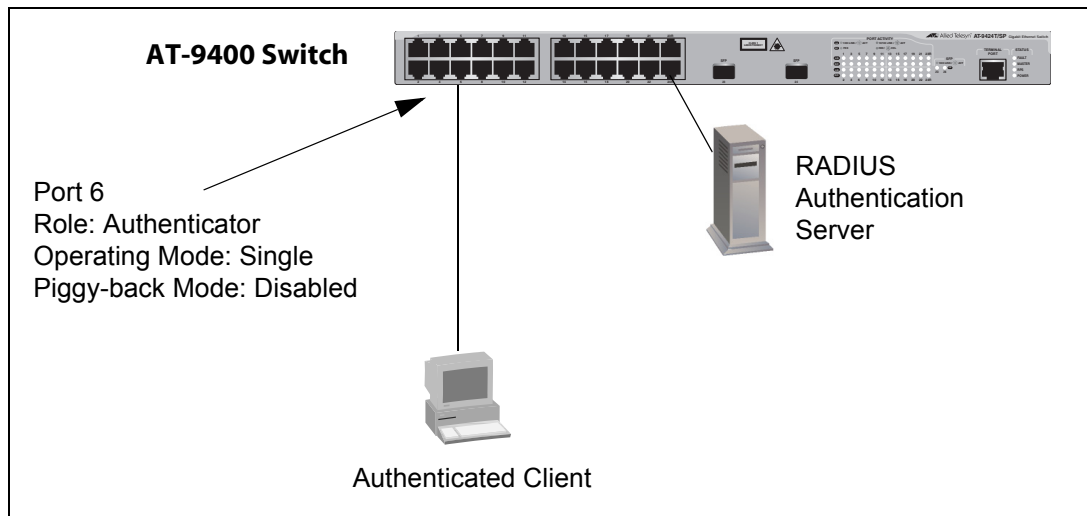

Figure 41. Authenticator Port in Single Operating Mode with a Single Client

The example in Figure 42 on page 389 illustrates a configuration that uses the piggy-back mode. Multiple clients are connected to an authenticator port on the switch through an Ethernet hub or a non-802.1x-compliant Ethernet switch, such as an unmanaged switch. The operating mode of the authenticator port on the AT-9400 Switch is set to Single and the piggy-back mode is enabled. This allows all clients to forward packets through the port after one client logs on.

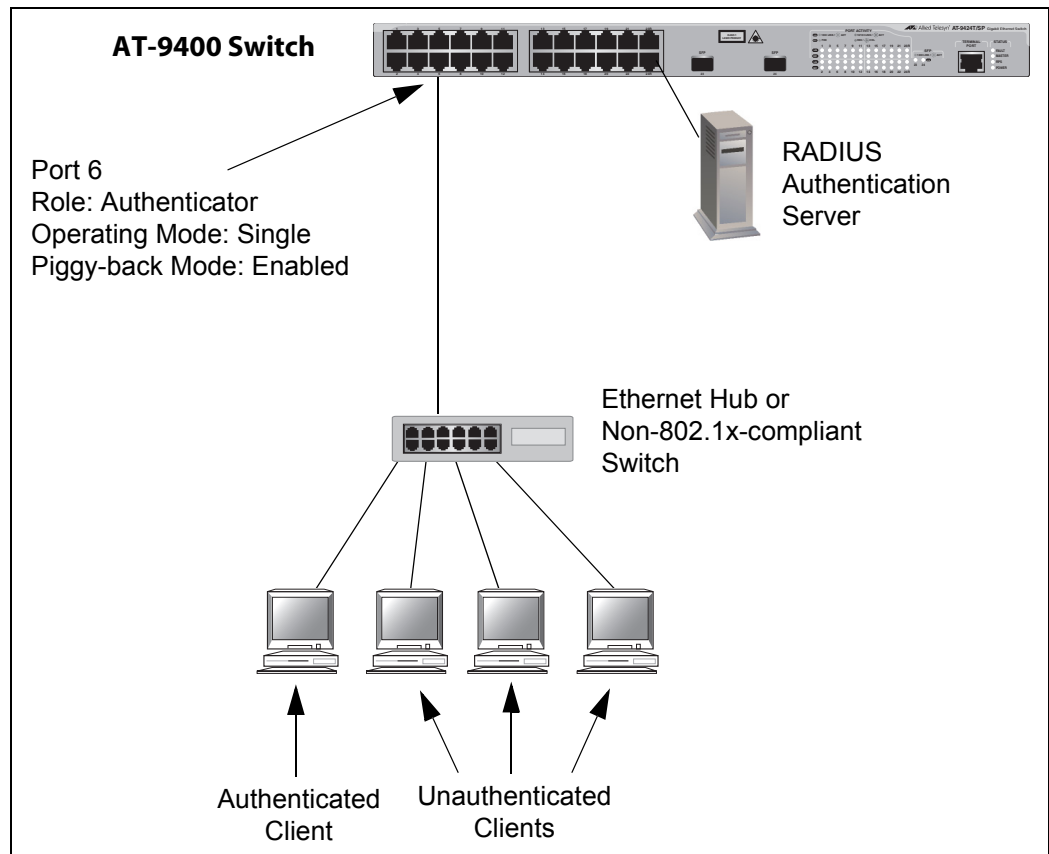

Figure 42. Single Operating Mode with Multiple Clients Using the Piggy-back Feature - Example 1

Because the piggy-back mode is activated on the authenticator port, only one client needs to be authenticated in order for all the clients to forward traffic through the port. If the port is using the 802.1x authentication method, then at least one client must have 802.1x client firmware and provide a username and password during authentication. (The other clients do not need 802.1x client firmware to forward traffic through the port after one client is authenticated.)

If the switch port is set to MAC address-based authentication, 802.1 client firmware is not required. The MAC address of the first client to forward traffic through the port is used for authentication. When that client is authenticated, all supplicants have access to the port.

As mentioned earlier, should the client who performed the initial log on fail to reauthenticate when necessary or log out, the port reverts to the unauthenticated state, blocking all traffic to and from all clients. Another client must be authenticated in order for all remaining clients to continue to forward traffic through the port.

If the clients are connected to an 802.1x-compliant device, such as another AT-9400 Switch, you can automate the initial log on and reauthentications by configuring one of the switch ports as a supplicant. In this manner, the log on and reauthentications are performed automatically. This scenario is illustrated in Figure 43.

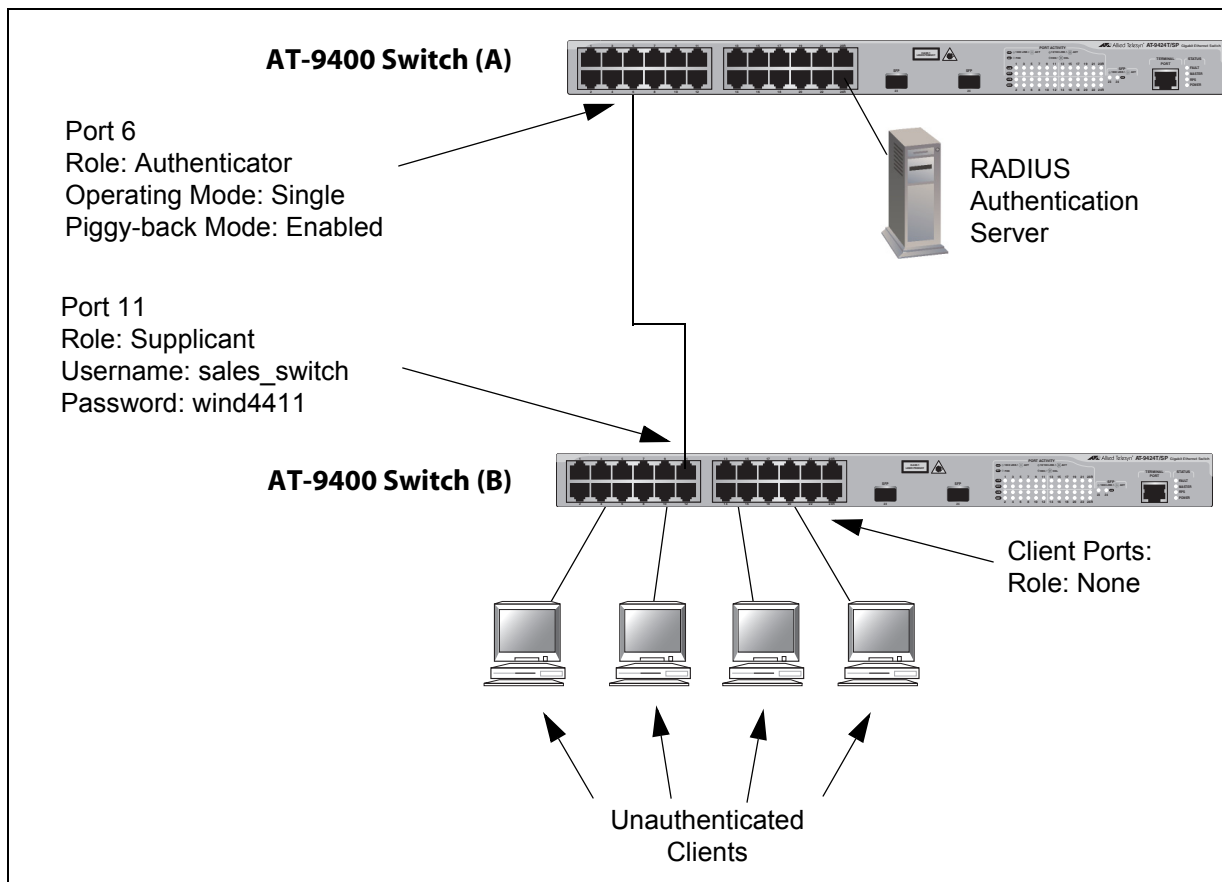

Figure 43. Single Operating Mode with Multiple Clients Using the Piggy-back Feature - Example 2

None of the workstations connected to switch B need to be authenticated or require 802.1x client software to access switch A. This is because the log on to switch A and the subsequent reauthentications are performed automatically by the supplicant port on switch B, which is connected to an authenticator port on switch A with piggy-back mode enabled. It should be noted, however, that in this particular scenario the clients have full access to the resources of switch B even if the switch fails to log on or reauthenticate to switch A.

The example in the next figure again illustrates two 802.1x-compliant switches. The primary difference between this and the previous example is that the clients in the previous example did not have to log on to access switch B. In this example the clients have to log on to have any access at all to the network.

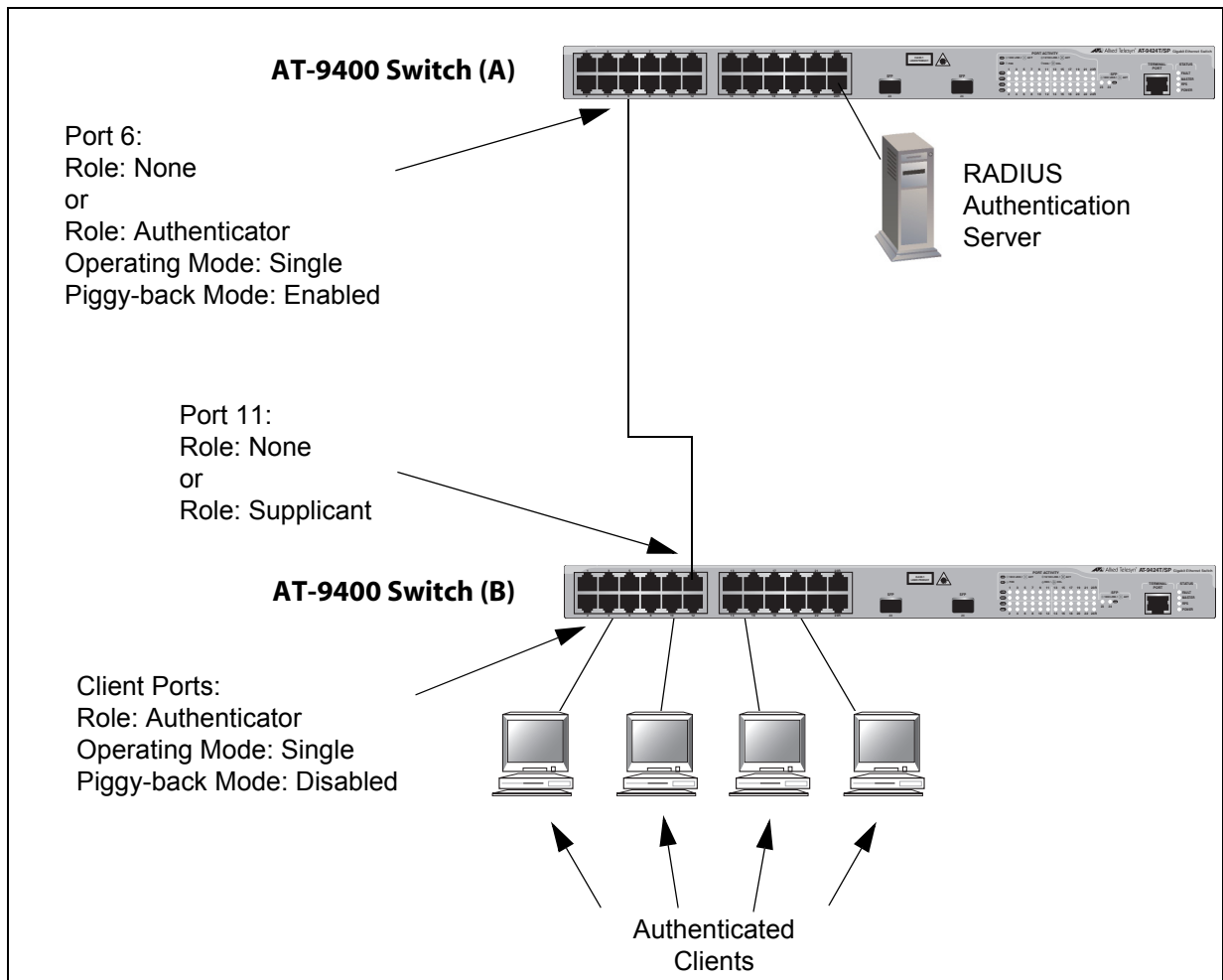

Figure 44. Single Operating Mode with Multiple Clients Using the Piggy-back Feature - Example 3

## Multiple Operating Mode

The second type of operating mode for an authenticator port is the Multiple mode. You use this mode when a port is supporting more than one client and you want each client to log on individually before being permitted to forward traffic through the port. An authenticator port in this mode can support up to a maximum of 320 clients, with a total maximum of 480 per switch. If you are using the 802.1x authentication method, you must provide each client with a separate username and password combination and the clients must provide their combinations to forward traffic through a switch port.

Selecting the Multiple mode for an authenticator port disables the piggy-back mode, because this operating mode does not permit piggy-backing.

An example of this authenticator operating mode is illustrated in Figure 45. The clients are connected to a hub or non-802.1x-compliant switch which is connected to an authenticator port on the AT-9400 Switch. If the authenticator port is set to the 802.1x authentication method, the clients must provide their username and password combinations before they can forward traffic through the AT-9400 Switch.

If the authentication method is MAC address-based, the authenticator port uses the MAC addresses of the clients as the username and password combinations. The port accepts and forwards traffic only from those clients whose MAC addresses have been entered on the RADIUS server and denies access to all other users.

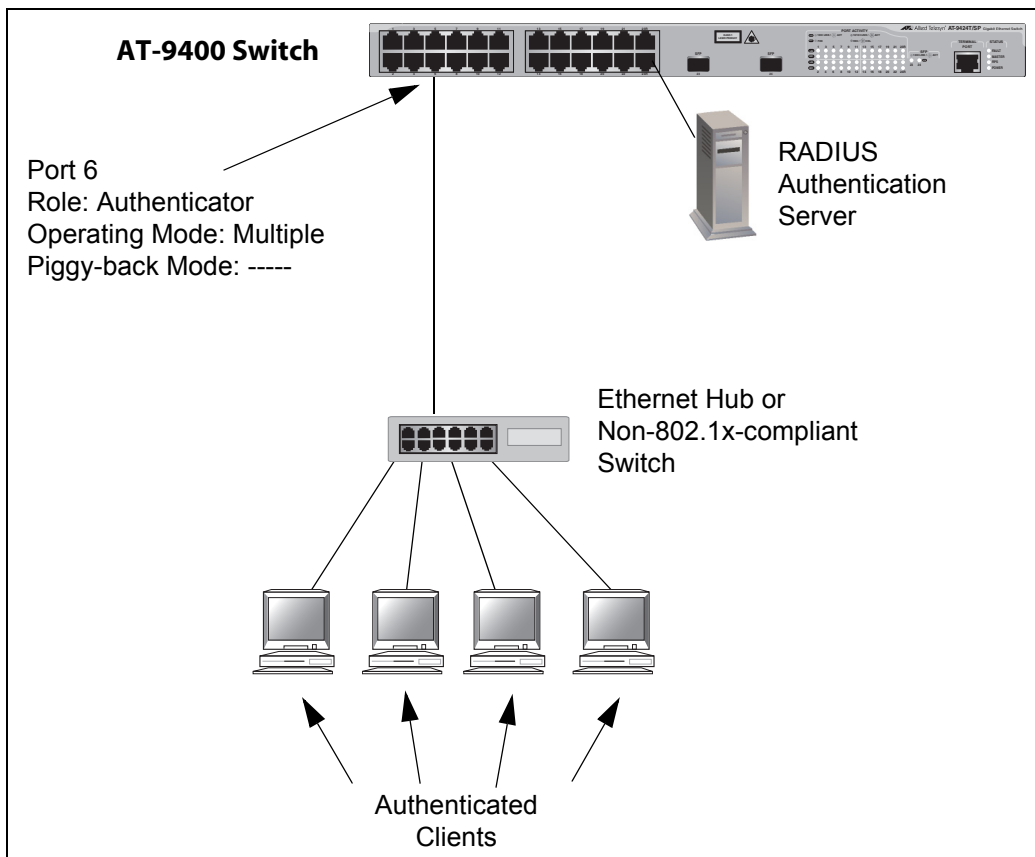

Figure 45. Authenticator Port in Multiple Operating Mode - Example 1

The next example of the multiple mode in Figure 46 shows two AT-9400 Switches. The clients connected to switch B have to log on to port 6 on Switch A when they pass a packet to that switch for the first time.

There are several items to note when interconnecting two 802.1x-compliant devices using the Multiple operating mode of an authenticator port. In order for switch B in our example to pass the RADIUS messages to switch A, it must be able to log on to port 6 on switch A. That is why port 11 on the lower switch is configured as a supplicant. If its role is set to



none, port 6 on switch A will discard the packets because switch B would not be logged on to the port.

Also notice that the ports where the clients are connected on switch B are set to the none role. This is because a client can log on only once. If, in this example, you were to make a client's port an authenticator, the client would have to log on twice when trying to access switch A, once on its port on switch B as well as the authenticator port on switch A. This is not permitted. Consequently, in our example the clients on switch B have full access to that switch, but are denied access to switch A until they log on to port 6 on switch A.

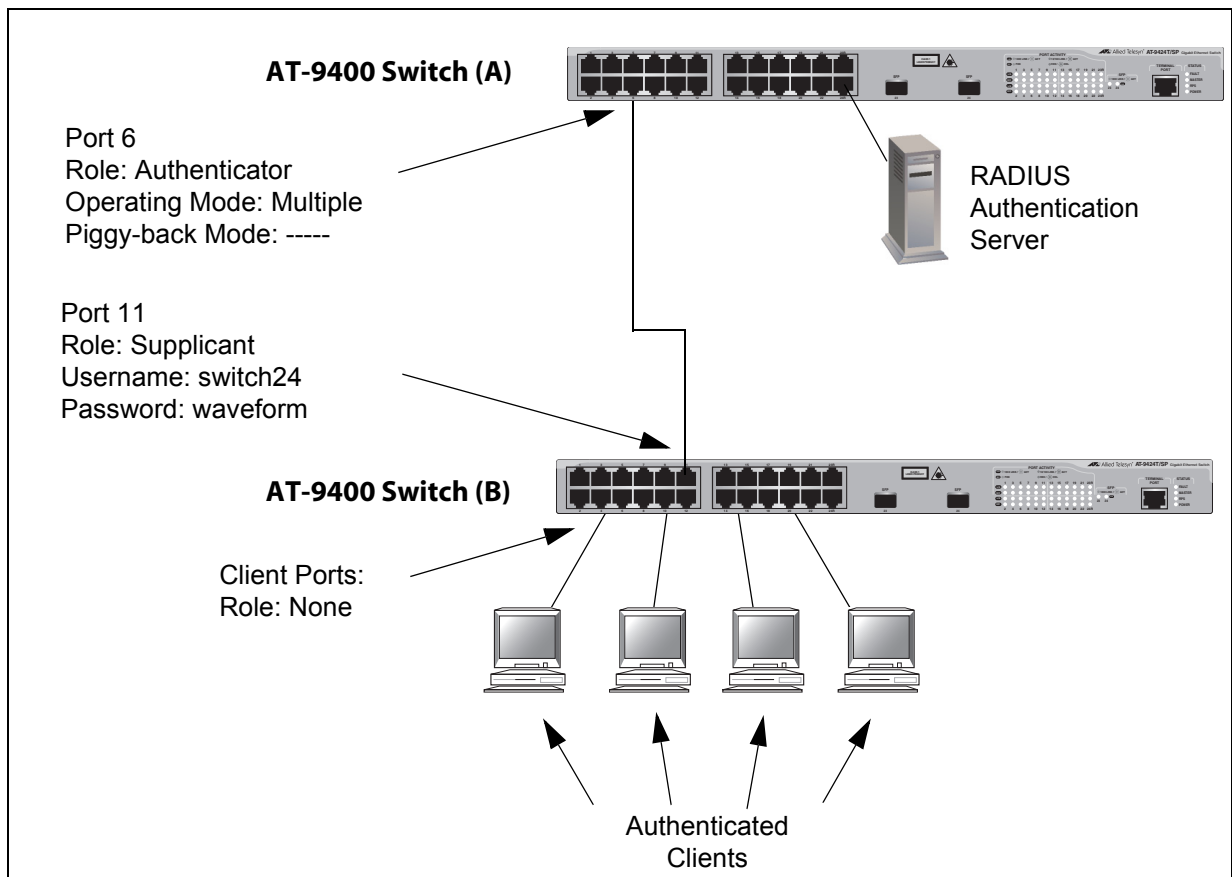

Figure 46. Authenticator Port in Multiple Operating Mode - Example 2

## Supplicant and VLAN Associations

---

One of the challenges to managing a network is accommodating end users that roam. These are individuals whose work requires that they access the network resources from different points at different times. The difficulty arises in providing them with access to the same network resources and, conversely, restricting them from unauthorized areas, regardless of the workstation from where they access the network. A closely related issue is where a workstation is employed at various times by different individuals with unique requirements in terms of network resources and security levels.

Providing network users with access to their network resources while also maintaining network security is often achieved through the use of VLANs. As explained in “Overview” on page 271, a VLAN is an independent traffic domain where the traffic generated by the nodes within the VLAN is restricted to nodes of the same VLAN, unless there is a router or Layer 3 device. Different users are assigned to different VLANs depending on their resource requirements and security levels.

The problem with a port-based VLAN is that VLAN membership is determined by the port on the switch to which the device is connected. If a different device that needs to belong to a different VLAN is connected to the port, the port must be manually moved to the new VLAN using the management software.

With 802.1x port-based network access control, you can link a username and password combination or MAC address to a specific VLAN so that the switch automatically moves the port to the appropriate VLAN when a client logs on. This frees the network manager from having to reconfigure VLANs as end users access the network from different points or where the same workstation is used by different individuals at different times.

To use this feature, you have to enter a VLAN identifier, along with other information, when you create a supplicant account on the RADIUS server. The server passes the identifier to the switch when a user logs on with a valid username and password combination or MAC address, depending on the authentication method. The information to provide on the RADIUS server is outlined in “Supplicant VLAN Attributes on the RADIUS Server” on page 395.

How the switch responds when it receives VLAN information during the authentication process can differ depending on the operating mode of the authenticator port.

## Single Operating Mode

Here are the operating characteristics for the switch when an authenticator port is set to the Single operating mode:

- ❑ If the switch receives a valid VLAN ID or VLAN name from the RADIUS server, it moves the authenticator port to the designated VLAN and changes the port to the authorized state. If the piggy-back mode is disabled, only the authenticated supplicant is allowed to use the port. All other supplicants are denied entry. If the piggy-back mode is enabled, all clients are allowed access to the port and the same VLAN after the initial authentication.
- ❑ If the switch receives an invalid VLAN ID or VLAN name from the RADIUS server (e.g., the VID of a nonexistent VLAN), it leaves the port in the unauthorized state to deny access to the port.

## Multiple Operating Mode

The initial authentication on an authenticator port running in the Multiple operating mode is handled in the same fashion as with the Single operating mode. If the switch receives a valid VLAN ID or name from the RADIUS server, it moves the authenticator port to the designated VLAN and changes the port to the authorized state.

How the switch handles subsequent authentications on the same port depends on how you set the Secure VLAN parameter. Your options are as follows:

- ❑ If you activate the Secure VLAN feature, only those supplicants with the same VLAN assignment as the initial supplicant are authenticated. Supplicants with different VLAN assignments or with no VLAN assignment are denied access to the port.
- ❑ If you disable the Secure VLAN feature, all supplicants, regardless of their assigned VLANs, are authenticated. However, the port remains in the VLAN specified in the initial authentication.

## Supplicant VLAN Attributes on the RADIUS Server

The following information must be entered as part of a supplicant's account on the RADIUS server when associating a supplicant to a VLAN.

- ❑ Tunnel-Type  
The protocol to be used by the tunnel specified by Tunnel-Private-Group-Id. The only supported value is VLAN (13).
- ❑ Tunnel-Medium-Type  
The transport medium to be used for the tunnel specified by Tunnel-Private-Group-Id. The only supported value is 802 (6).
- ❑ Tunnel-Private-Group-ID  
The ID of the tunnel the authenticated user should use. This must be the name of VID of the VLAN of the switch.

## Guest VLAN

---

An authenticator port in the unauthorized state typically accepts and transmits only 802.1x packets while waiting to authenticate a supplicant. However, you can configure an authenticator port to be a member of a Guest VLAN when no supplicant is logged on. Any client using the port is not required to log on and has full access to the resources of the Guest VLAN.

If the switch receives 802.1x packets on the port, signalling that a supplicant is logging on, it moves the port to its predefined VLAN and places it in the unauthorized state. The port remains in the unauthorized state until the log on process between the supplicant and the RADIUS server is completed. When the supplicant logs off, the port automatically returns to the Guest VLAN.

---

**Note**

The Guest VLAN feature is only supported on an authenticator port in the Single operating mode.

---

## RADIUS Accounting

---

The AT-S63 Management Software supports RADIUS accounting for switch ports set to the Authenticator role. This feature sends information about the status of the supplicants to the RADIUS server so that you can monitor network activity and use.

The switch sends accounting information to the RADIUS server when the following events occur:

- ❑ Supplicants log on
- ❑ Supplicants logs off
- ❑ Authenticator ports change states during active supplicant sessions (for example, a port is reset or is changed from the Authenticator role to None role while a supplicant is logged on)

The information that the switch sends to the RADIUS server for an event includes:

- ❑ The port number where an event occurred
- ❑ The date and time when an event occurred
- ❑ The number of packets transmitted and received by a switch port during a supplicant's session. (This information is sent only when a client logs off.)

You can also configure the accounting feature to send interim updates so you can monitor which clients are still active.

Here are the guidelines to using the accounting feature:

- ❑ The AT-S63 Management Software supports the Network level of accounting, but not the System or Exec.
- ❑ This feature is only available for ports operating in the Authenticator role. No accounting is provided for ports operating in the Supplicant or None role.
- ❑ You must configure 802.1x Port-based Network Access Control as explained in this chapter and designate the Authenticator ports.
- ❑ You must also specify from one to three RADIUS servers.

## General Steps

---

Here are the general steps to implementing 802.1x Port-based Network Access Control and RADIUS accounting on the switch:

1. You must install a RADIUS server on one or more of your network servers or management stations. Authentication protocol server software is not available from Allied Telesis. Funk Software Steel-Belted Radius and Free Radius have been verified as fully compatible with the AT-S63 Management Software.

---

**Note**

This feature is not supported with the TACACS+ authentication protocol.

---

2. Those clients connected to an authenticator port set to the 802.1x authentication method will need 802.1x client software. Microsoft WinXP client software and Meeting House Aegis client software have been verified as fully compatible with the AT-S63 Management Software. (802.1x client software is not required when an authenticator port is set to the MAC address-based authentication method.)
3. You must configure and activate the RADIUS client software in the AT-S63 Management Software. The default setting for the authentication protocol is disabled. You will need to provide the following information:
  - The IP addresses of up to three RADIUS servers.
  - The encryption keys used by the authentication servers.
4. You must configure the port access control settings on the switch. This involves the following:
  - Specifying the port roles.
  - Configuring 802.1x port parameters.
  - Enabling 802.1x Port-based Network Access Control.

The instructions for this step are found in this chapter.

5. If you want to use RADIUS accounting to monitor the clients connected to the switch ports, you must configure the service on the switch.

## Guidelines

---

The following are general guidelines to using this feature:

- ❑ Ports operating under port-based access control do not support dynamic MAC address learning.
- ❑ The appropriate port role for a port on the AT-9400 Switch connected to a RADIUS authentication server is None.
- ❑ The authentication method of an authenticator port can be either 802.1x username and password combination or MAC address-based, but not both.
- ❑ A supplicant must have 802.1x client software if the authentication method of a switch port is 802.1x username and password combination.
- ❑ A supplicant does not need 802.1x client software if the authentication method of an authenticator port is MAC address-based.
- ❑ An authenticator port set to the multiple operating mode can support up to a maximum of 320 authenticated supplicants at one time.
- ❑ The switch can handle up to a maximum of 480 authenticated supplicants at one time. The switch stops accepting new authentications after the maximum is reached and starts accepting new authentications as supplicants log out or are timed out.
- ❑ An 802.1x username and password combination is not tied to the MAC address of an end node. This allows end users to use the same username and password when working at different workstations.
- ❑ After a client has successfully logged on, the MAC address of the end node is added to the switch's MAC address table as an authenticated address. It remains in the table until the client logs off the network or fails to reauthenticate, at which point the address is removed. The address is not timed out, even if the node becomes inactive.

---

### Note

End users of 802.1x port-based network access control should be instructed to always log off when they are finished with a work session. This can prevent unauthorized individuals from accessing the network through unattended network workstations.

---

- ❑ Authenticator and supplicant ports must be untagged ports. They cannot be tagged ports of any VLAN.
- ❑ The MAC address-based port security setting for an authenticator port must be Automatic. This restriction does not apply to a supplicant port. For further information, refer to Chapter 32, "MAC Address-based Port Security" on page 373.

- ❑ An authenticator port cannot be part of a static port trunk, LACP port trunk, or port mirror.
- ❑ If a switch port set to the supplicant role is connected to a port on another switch that is not set to the authenticator role, the port, after a timeout period, assumes that it can send traffic without having to log on.
- ❑ GVRP must be disabled on an authenticator port.
- ❑ When 802.1x port-based network access control is activated on a switch, the feature polls all RADIUS servers specified in the RADIUS configuration. If three servers have been configured, the switch polls all three. If server 1 responds, all future requests go only to that server. If server 1 stops responding, the switch again polls all RADIUS servers. If server 2 responds, but not server 1, then all future requests go to servers 1 and 2. If only server 3 responds, then all future requests go to all three servers.
- ❑ In order to change the untagged VLAN assignment of an authenticator or supplicant port, you must set its port role to none. You can change the port's role back to authenticator or supplicant after you have changed the port's VLAN assignment.
- ❑ To use the Guest VLAN feature, the designated VLAN must already exist on the switch.
- ❑ A Guest VLAN can be either port-based or tagged.
- ❑ The switch must be running in the user-configured VLAN mode to support 802.1x port-based network access control. The feature is not supported in the multiple VLAN modes.
- ❑ Starting with version 3.0.0, the AT-S63 Management Software supports EAP-MD5, EAP-TLS, EAP-TTLS, and EAP-PEAP authentication for both authenticators and supplicants. Prior to version 3.0.0, only EAP-MD5 was supported.
- ❑ The switch must have a routing interface on the local subnet where the RADIUS server is a member. The switch uses the routing interface's IP address as its source address when communicating with the server. For background information, refer to "Routing Interfaces and Management Features" on page 342.

---

**Note**

Prior to version 2.0.0 of the AT-S63 Management Software, the RADIUS server had to be a member of the switch's management VLAN. This restriction no longer applies. The server can be located on any local subnet on the switch that has a routing interface.

---



Here are guidelines for adding VLAN assignments to supplicant accounts on a RADIUS server:

- ❑ The VLAN can be either port-based or tagged.
- ❑ The VLAN must already exist on the switch.
- ❑ A client can have only one VLAN associated with it on the RADIUS server.
- ❑ When a supplicant logs on, the switch port is moved as an untagged port to the designated VLAN.



## Section IX

# Management Security

---

The chapters in this section describe the management security features of the AT-9400 Switch. The chapters include:

- ❑ Chapter 34, “Web Server” on page 405
- ❑ Chapter 35, “Encryption Keys” on page 411
- ❑ Chapter 36, “PKI Certificates and SSL” on page 421
- ❑ Chapter 37, “Secure Shell (SSH)” on page 437
- ❑ Chapter 38, “TACACS+ and RADIUS Protocols” on page 447
- ❑ Chapter 39, “Management Access Control List” on page 455



## Chapter 34

# Web Server

---

The sections in this chapter are:

- ❑ “Supported Platforms” on page 406
- ❑ “Overview” on page 407
- ❑ “Configuring the Web Server for HTTP” on page 408
- ❑ “Configuring the Web Server for HTTPS” on page 409

## Supported Platforms

---

Refer to Table 104 and Table 105 for the AT-9400 Switches and the management interfaces that support the web server.

Table 104. Support for the Web Server

Switch	Supported
Layer 2+ Models	
AT-9408LC/SP	Yes
AT-9424T/GB	Yes
AT-9424T/SP	Yes
Basic Layer 3 Models	
AT-9424T	Yes
AT-9424T/POE	Yes
AT-9424Ts	Yes
AT-9424Ts/XP	Yes
AT-9448T/SP	Yes
AT-9448Ts/XP	Yes
AT-9400Ts Stack	Yes

Table 105. Management Interfaces for the Web Server

Switch or Stack	Standard Command Line	AlliedWare Plus Command Line	Menus	Web Browser
Stand-alone Switch	Yes	Yes	Yes	
AT-9400Ts Stack	Yes	Yes		

## Overview

---

The AT-S63 Management Software has a web server and a special web browser interface that allow you to remotely manage the switch from a management workstation on your network using a web browser. (For instructions on the switch's web browser interface, refer to the *AT-S63 Management Software Web Browser Interface User's Guide*.)

The web server on the switch can operate in HTTP or HTTPS mode. A management session conducted in the HTTP mode is not secure because the packets are transmitted in plaintext, including the manager's login name and password. Should someone be monitoring the traffic on your network during a management session, the security of the unit could be jeopardize.

In contrast, a management session conducted in the HTTPS mode is secure because the load in the management packets is encrypted with the Secure Sockets Layer (SSL) protocol. This mode requires an encryption key pair and a certificate. For background information, refer to Chapter 35, "Encryption Keys" on page 411 and Chapter 36, "PKI Certificates and SSL" on page 421.

The default setting for the web server is disabled, with the non-secure HTTP mode as the default active mode.

For background information and guidelines on remote management, refer to the *Starting an AT-S63 Management Session Guide*.

---

**Note**

To use HTTPS in an enhanced stack, all switches in the stack must use HTTPS. For further information, refer to "SSL and Enhanced Stacking" on page 427.

---

### Supported Protocols

The switch supports the following HTTP and HTTPs protocols:

- HTTP v1.0 and v1.1 protocols
- HTTPS v1.0 and v1.1 protocols running over SSL

The switch supports the following SSL protocols:

- SSL version 2.0
- SSL version 3.0
- TLS (Transmission Layer Security) version 1.0

## Configuring the Web Server for HTTP

---

The following steps configure the web server for non-secure HTTP operation. The steps reference only the command line commands, but the web server can be configured from the menus interface, too.

1. Disable the web server with the `DISABLE HTTP SERVER` command.
2. Activate HTTP in the web server with the `SET HTTP SERVER` command.
3. Enable the web server with the `ENABLE HTTP SERVER` command.



## Configuring the Web Server for HTTPS

---

The following sections outline the steps for configuring the web server on the switch for HTTPS operation with a self-signed or CA certificate. The steps reference only the command line commands, but the web server can be configured from the menus interface, too.

### General Steps for a Self-signed Certificate

These steps configure the web server with a self-signed certificate:

1. Set the switch's date and time. The date and time are stamped in the certificate.
2. Create a public and private key pair with the CREATE ENCO KEY command.
3. Create a self-signed certificate using the public and private key pair with the CREATE PKI CERTIFICATE command.
4. Add the certificate to the certificate database with the ADD PKI CERTIFICATE command.
5. Disable the web server with the DISABLE HTTP SERVER command.
6. Activate HTTPS in the web server with the SET HTTP SERVER command.
7. Enable the web server with the ENABLE HTTP SERVER command.

For an example of this command sequence, refer to the SET HTTP SERVER command in the *AT-S63 Management Software Command Line Interface User's Guide*.

### General Steps for a Public or Private CA Certificate

These steps configure the web server with a public or private CA certificate.

1. Set the switch's date and time. The date and time are stamped in the enrollment request.
2. Create a public and private key pair with the CREATE ENCO KEY command.
3. Generate an enrollment request with the CREATE PKI ENROLLMENTREQUEST command.
4. Upload the enrollment request from the switch's file system with the UPLOAD METHOD=TFTP or UPLOAD METHOD=XMODEM command.
5. Submit the enrollment request to a public or private CA.

6. After receiving the certificates from the CA, download them into the switch's file system using the LOAD METHOD=TFTP or LOAD METHOD=XMODEM command.
7. Add the certificates to the certificate database with the ADD PKI CERTIFICATE command.
8. Disable the web server with the DISABLE HTTP SERVER command.
9. Activate HTTPS in the web server with the SET HTTP SERVER command.
10. Enable the web server with the ENABLE HTTP SERVER command.

For an example of this command sequence, refer to the SET HTTP SERVER command in the *AT-S63 Management Software Command Line Interface User's Guide*.

## Chapter 35

# Encryption Keys

---

The sections in this chapter are:

- ❑ “Supported Platforms” on page 412
- ❑ “Overview” on page 413
- ❑ “Encryption Key Length” on page 414
- ❑ “Encryption Key Guidelines” on page 415
- ❑ “Technical Overview” on page 416

For an overview of the procedures to configuring the switch’s web server for encryption, refer to “Configuring the Web Server for HTTPS” on page 409.

## Supported Platforms

---

Refer to Table 106 and Table 107 for the AT-9400 Switches and the management interfaces that support encryption keys.

Table 106. Support for Encryption Keys

Switch	Supported
Layer 2+ Models	
AT-9408LC/SP	Yes
AT-9424T/GB	Yes
AT-9424T/SP	Yes
Basic Layer 3 Models	
AT-9424T	Yes
AT-9424T/POE	Yes
AT-9424Ts	Yes
AT-9424Ts/XP	Yes
AT-9448T/SP	Yes
AT-9448Ts/XP	Yes
AT-9400Ts Stack	Yes

Table 107. Management Interfaces for Encryption Keys

Switch or Stack	Standard Command Line	AlliedWare Plus Command Line	Menus	Web Browser
Stand-alone Switch	Yes	Yes	Yes	Yes <sup>1</sup>
AT-9400Ts Stack	Yes	Yes		

1. You can view the encryption keys on a stand-alone switch from the web browser interface, but you cannot create or delete them.

## Overview

---

Protecting your managed switches from unauthorized management access is an important role for a network manager. Network operations and security can be severely compromised if an intruder gains access to critical switch information, such as a manager's login username and password, and uses that information to alter a switch's configuration settings.

One way an intruder could obtain critical switch information is by monitoring network traffic with a network analyzer, such as a sniffer, and capturing management packets from remote Telnet or web browser management sessions. The payload in the packets exchanged during remote management sessions is transmitted in plaintext. The information obtained from the management packets could enable an intruder to access a switch.

A way to prevent this type of assault is by encrypting the payload in the packets exchanged during a remote management session between a management station and a switch. Encryption makes the packets unintelligible to an outside agent. Only the remote workstation and the switch engaged in the management session are able to decode each other's packets.

A fundamental part of encryption is the encryption key. The key converts plaintext into encrypted text, and back again. A key consists of two separate keys: a private key and a public key. Together they create a *key pair*.

The AT-S63 Management Software supports encryption for remote web browser management sessions using the Secure Sockets Layer (SSL) protocol. Adding encryption to your web browser management sessions involves creating one key pair and adding the public key of the key pair to a certificate, a digital document stored on the switch. You can have the switch create the certificate itself or you can have a public or private certificate authority (CA) create it for you. For an overview of the steps for adding encryption to your web browser management sessions, refer to "Configuring the Web Server for HTTPS" on page 409.

The Telnet protocol does not support encryption. To employ encryption when remotely managing a switch using the menus interface, you must first obtain a Secure Shell (SSH) protocol application. SSH offers the same function as Telnet, but with encryption.

SSH encryption requires that you create two key pairs on the switch— a server key pair and a host key pair and then configure the Secure Shell protocol server software on the switch, as explained in Chapter 37, "Secure Shell (SSH)" on page 437.

## Encryption Key Length

---

When you create a key pair, you have to specify its length in bits. The range is 512, the default, to 1,536 bits, in increments of 256 bits. The longer the key, the more difficult it is for someone to decipher. If you are particularly concerned about the safety of your management sessions, you might want to use a longer key length than the default, though the default is likely to be sufficient in most situations.

Creating a key is a very CPU intensive operation for the switch. Although the switch does not stop forwarding packets between the ports, the process can impact the CPU's handling of network events, such as the processing of spanning tree BPDU packets, which can result in unexpected and unwanted switch behavior.

A key with the default length should take the switch less than a minute to create. Longer keys can take up to 15 minutes. You should take this into account when creating a key to minimize the impact to the operations of your network. If you intend to create a long key, consider creating it before you connect the switch to the network, or during periods of low network traffic.

## Encryption Key Guidelines

---

Observe the following guidelines when creating an encryption key pair:

- ❑ Web browser encryption requires only one key pair.
- ❑ SSH encryption requires two key pairs. The keys must be of different lengths of at least one increment (256 bits) apart. The recommended size for the server key is 768 bits and the recommended size for the host key is 1024 bits.
- ❑ The AT-9400 Switch can only use those key pairs it has generated itself. The switch cannot use a key created on another system and imported onto the switch.
- ❑ The AT-S63 Management Software does not allow you to copy or export a private key from a switch. However, you can export a public key.
- ❑ The AT-S63 Management Software uses the RSA public key algorithm.
- ❑ Web browser and SSH encryption can share a key pair on the switch.

## Technical Overview

---

The encryption feature provides the following data security services:

- ❑ Data encryption
- ❑ Data authentication
- ❑ Key exchange algorithms
- ❑ Key creation and storage

### Data Encryption

Data encryption for switches is driven by the need for organizations to keep sensitive data private and secure. Data encryption operates by applying an encryption algorithm and key to the original data (the plaintext) to convert it into an encrypted form (the ciphertext). The ciphertext produced by encryption is a function of the algorithm used and the key. Because it is easy to discover what type of algorithm is being used, the security of an encryption system relies on the secrecy of its key information. When the ciphertext is received by the remote router, the decryption algorithm and key are used to recover the original plaintext. Often, a checksum is added to the data before encryption. The checksum allows the validity of the data to be checked on decryption.

There are two main classes of encryption algorithm in use: symmetrical encryption and asymmetrical encryption.

#### Symmetrical Encryption

Symmetrical encryption refers to algorithms in which a single key is used for both the encryption and decryption processes. Anyone who has access to the key used to encrypt the plaintext can decrypt the ciphertext. Because the encryption key must be kept secret to protect the data, these algorithms are also called private, or secret key algorithms. The key can be any value of the appropriate length.

#### DES Encryption Algorithms

The most common symmetrical encryption system is the *Data Encryption Standard* (DES) algorithm (FIPS PUB 46). The DES algorithm has withstood the test of time and proved itself to be a highly secure encryption algorithm. To fully conform to the DES standard, the actual data encryption operations must be carried out in hardware. Software implementations can only be DES-compatible, not DES-compliant. The DES algorithm has a key length of 56 bits and operates on 64-bit blocks of data. DES can be used in the following modes:

- ❑ **Electronic Code Book (ECB)** is the fundamental DES function. Plaintext is divided into 64-bit blocks which are encrypted with the DES



algorithm and key. For a given input block of plaintext ECB always produces the same block of ciphertext.

- ❑ **Cipher Block Chaining (CBC)** is the most popular form of DES encryption. CBC also operates on 64-bit blocks of data, but includes a feedback step which chains consecutive blocks so that repetitive plaintext data, such as ASCII blanks, does not yield identical ciphertext. CBC also introduces a dependency between data blocks which protects against fraudulent data insertion and replay attacks. The feedback for the first block of data is provided by a 64-bit Initialization Vector (IV). This is the DES mode used for the switch's data encryption process.
- ❑ **Cipher FeedBack (CFB)** is an additive-stream-cipher method which uses DES to generate a pseudo-random binary stream that is combined with the plaintext to produce the ciphertext. The ciphertext is then fed back to form a portion of the next DES input block.
- ❑ **Output FeedBack (OFB)** combines the first IV DES algorithms with the plaintext to form ciphertext. The ciphertext is then used as the next IV.

The DES algorithm has been optimized to produce very high speed hardware implementations, making it ideal for networks where high throughput and low latency are essential.

### Triple DES Encryption Algorithms

The Triple DES (3DES) encryption algorithm is a simple variant on the DES CBC algorithm. The DES function is replaced by three rounds of that function, an encryption followed by a decryption followed by an encryption. This can be done by using either two DES keys (112-bit key) or three DES keys (168-bit key).

The two-key algorithm encrypts the data with the first key, decrypts it with the second key and then encrypts the data again with the first key. The three-key algorithm uses a different key for each step. The three-key algorithm is the most secure algorithm due to the long key length.

There are several modes in which Triple DES encryption can be performed. The two most common modes are:

- ❑ **Inner CBC mode** encrypts the entire packet in CBC mode three times and requires three different initial is at ion vectors (IV's).
- ❑ **Outer CBC mode** triple encrypts each 8-byte block of a packet in CBC mode three times and requires one IV.

### Asymmetrical (Public Key) Encryption

Asymmetrical encryption algorithms use two keys—one for encryption and one for decryption. The encryption key is called the public key because it cannot be used to decrypt a message and therefore does not need be kept

secret. Only the decryption, or private key, needs to be kept secret. The other name for this type of algorithm is public key encryption. The public and private key pair cannot be randomly assigned, but must be generated together. In a typical scenario, a decryption station generates a key pair and then distributes the public key to encrypting stations. This distribution does not need to be kept secret, but it must be protected against the substitution of the public key by a malicious third party. Another use for asymmetrical encryption is as a digital signature. The signature station publishes its public key, and then signs its messages by encrypting them with its private key. To verify the source of a message, the receiver decrypts the messages with the published public key. If the message that results is valid, then the signing station is authenticated as the source of the message.

The most common asymmetrical encryption algorithm is RSA. This algorithm uses mathematical operations which are relatively easy to calculate in one direction, but which have no known reverse solution. The security of RSA relies on the difficulty of factoring the modulus of the RSA key. Because key lengths of 512 bits or greater are used in public key encryption systems, decrypting RSA encrypted messages is almost impossible using current technology. The AT-S63 Management Software uses the RSA algorithm.

Asymmetrical encryption algorithms require enormous computational resources, making them very slow when compared to symmetrical algorithms. For this reason they are normally only used on small blocks of data (for example, exchanging symmetrical algorithm keys), and not for entire data streams.

## **Data Authentication**

Data authentication for switches is driven by the need for organizations to verify that sensitive data has not been altered.

Data authentication operates by calculating a message authentication code (MAC), commonly referred to as a *hash*, of the original data and appending it to the message. The MAC produced is a function of the algorithm used and the key. Because it is easy to discover what type of algorithm is being used, the security of an authentication system relies on the secrecy of its key information. When the message is received by the remote switch, another MAC is calculated and checked against the MAC appended to the message. If the two MACs are identical, the message is authentic.

Typically a MAC is calculated using a keyed one-way hash algorithm. A keyed one-way hash function operates on an arbitrary-length message and a key. It returns a fixed length hash. The properties which make the hash function one-way are:

- ❑ It is easy to calculate the hash from the message and the key
- ❑ It is very hard to compute the message and the key from the hash

- It is very hard to find another message and key which give the same hash

The two most commonly used one-way hash algorithms are MD5 (Message Digest 5, defined in RFC 1321) and SHA-1 (Secure Hash Algorithm, defined in FIPS-180-1). MD5 returns a 128-bit hash and SHA-1 returns a 160-bit hash. MD5 is faster in software than SHA-1, but SHA-1 is generally regarded to be slightly more secure.

HMAC is a mechanism for calculating a keyed Message Authentication Code which can use any one-way hash function. It allows for keys to be handled the same way for all hash functions and it allows for different sized hashes to be returned.

Another method of calculating a MAC is to use a symmetric block cipher such as DES in CBC mode. This is done by encrypting the message and using the last encrypted block as the MAC and appending this to the original message (plain-text). Using CBC mode ensures that the whole message affects the resulting MAC.

## Key Exchange Algorithms

Key exchange algorithms are used by switches to securely generate and exchange encryption and authentication keys with other switches. Without key exchange algorithms, encryption and authentication session keys must be manually changed by the system administrator. Often, it is not practical to change the session keys manually. Key exchange algorithms enable switches to re-generate session keys automatically and on a frequent basis.

The most important property of any key exchange algorithm is that only the negotiating parties are able to decode, or generate, the shared secret. Because of this requirement, public key cryptography plays an important role in key exchange algorithms. Public key cryptography provides a method of encrypting a message which can only be decrypted by one party. A switch can generate a session key, encrypt the key using public key cryptography, transmit the key over an insecure channel, and be certain that the key can only be decrypted by the intended recipient. Symmetrical encryption algorithms can also be used for key exchange, but commonly require an initial shared secret to be manually entered into all switches in the secure network.

The *Diffie-Hellman* algorithm, which is used by the AT-S63 Management Software, is one of the more commonly used key exchange algorithms. It is not an encryption algorithm because messages cannot be encrypted using Diffie-Hellman. Instead, it provides a method for two parties to generate the same shared secret with the knowledge that no other party can generate that same value. It uses public key cryptography and is commonly known as the first public key algorithm. Its security is based on the difficulty of solving the *discrete logarithm problem*, which can be compared to the difficulty of factoring very large integers.

A Diffie-Hellman algorithm requires more processing overhead than RSA-based key exchange schemes, but it does not need the initial exchange of public keys. Instead, it uses published and well tested public key values. The security of the Diffie-Hellman algorithm depends on these values. Public key values less than 768 bits in length are considered to be insecure.

A Diffie-Hellman exchange starts with both parties generating a large random number. These values are kept secret, while the result of a public key operation on the random number is transmitted to the other party. A second public key operation, this time using the random number and the exchanged value, results in the shared secret. As long as no other party knows either of the random values, the secret is safe.

## Chapter 36

# PKI Certificates and SSL

---

The sections in this chapter are:

- ❑ “Supported Platforms” on page 422
- ❑ “Overview” on page 423
- ❑ “Types of Certificates” on page 423
- ❑ “Distinguished Names” on page 425
- ❑ “SSL and Enhanced Stacking” on page 427
- ❑ “Guidelines” on page 428
- ❑ “Technical Overview” on page 429

## Supported Platforms

---

Refer to Table 108 and Table 109 for the AT-9400 Switches and the management interfaces that support the PKI certificates and SSL.

Table 108. Support for PKI Certificates and SSL

Switch	Supported
Layer 2+ Models	
AT-9408LC/SP	Yes
AT-9424T/GB	Yes
AT-9424T/SP	Yes
Basic Layer 3 Models	
AT-9424T	Yes
AT-9424T/POE	Yes
AT-9424Ts	Yes
AT-9424Ts/XP	Yes
AT-9448T/SP	Yes
AT-9448Ts/XP	Yes
AT-9400Ts Stack	Yes

Table 109. Management Interfaces for PKI Certificates and SSL

Switch or Stack	Standard Command Line	AlliedWare Plus Command Line	Menus	Web Browser
Stand-alone Switch	Yes		Yes	Yes <sup>1</sup>
AT-9400Ts Stack	Yes			

1. You can use the web browser interface on a stand-alone switch to view the PKI certificates and the SSL and PKI settings. But to manage the certificates or change the settings, you must use the command line interface or the menus interface.

## Overview

---

This chapter describes the second part of the encryption feature of the AT-S63 Management Software—PKI certificates. The first part is explained in Chapter 35, “Encryption Keys” on page 411. Encryption keys and certificates allow you to encrypt the communications between your management station and a switch during a web browser management session, and so protect your switch from intruders who might be using a sniffer to monitor the network for management packets.

## Types of Certificates

---

As explained in the previous chapter, an encryption key encrypts the information in the frames exchanged between a switch and a web browser during a web browser management session. An encryption key consists of two parts: a private key and a public key. The private key remains on the switch and is used by the device to encrypt its messages.

The public key is incorporated into a certificate and is used by your management station when you perform a web browser management session. Your web browser downloads the certificate with the public key from the switch when you begin a management session.

The quickest and easiest way to create a certificate is to have the switch create it. This type of certificate is called a *self-signed certificate*. If you have a small to medium sized network, this will probably be the best approach. To review all the steps to configuring the web server for a self-signed certificate, refer to “Configuring the Web Server for HTTPS” on page 409.

Another option is to create the key but have someone else issue the certificate. That person, group, or organization is called a *certification authority (CA)*.

There are two kinds of CAs: public and private. A public CA issues certificates typically intended for use by the general public for other companies and organizations. A public CA requires proof of the identify of the company or organization before issuing a certificate. VeriSign is an example of a public CA.

Because a certificate for the AT-9400 Switch is not intended for general use and will only be used by you and other network managers in managing the switch, it probably will not be necessary for you to have a public CA issue the certificate for the switch.

Some large companies have private CAs. This is a person or group within the company that is responsible for issuing certificates for the company’s

network equipment. With private CAs, companies can keep track of the certificates and control access to various network devices.

If your company is large enough, it might have a private CA and you might want the group to issue the certificate for the AT-9400 Switch so that you are in compliance with company policy.

The first step to creating a CA certificate is to create a key pair. After that you must generate a digital document called an *enrollment request* and send the document to the CA. The document contains the public key and other information that the CA will use to create the certificate.

Before sending an enrollment request to a CA, it is best to first contact the CA to determine what other documents or procedures might be required in order for the CA to create the certificate. This is particularly important with public CAs, which typically have strict guidelines on issuing certificates.



## Distinguished Names

---

Part of the task to creating a self-signed certificate or enrollment request is selecting a *distinguished name*. A distinguished name is integrated into a certificate along with the key and can have up to five parts. The parts are:

- cn - common name

This can be the name of the person who will use the certificate.

- ou - organizational unit

This is the name of a department, such as Network Support or IT.

- o - organization

This is the name of the company.

- st - state

This is the state.

- c - country

This is the country

A certificate name does not need to contain all of these parts. You can use as many or as few as you want. You separate the parts with a comma. You can use alphanumeric characters, as well as spaces in the name strings. You cannot use quotation marks. To use the following special characters {=,+<>#;\<CR>}, type a “\” before the character.

Following are a few examples. This distinguished name contains only one part, the name of the switch:

```
cn=Production Switch
```

This distinguished name omits the common name, but includes everything else:

```
ou=Network Support,o=XYZ Inc.,st=CA,c=US
```

So what would be a good distinguished name for a certificate for the AT-9400 Switch? If the switch has an IP address, such as a master switch of an enhanced stack, you could use its address as the name. The following example is a distinguished name for a certificate for a master switch with the IP address 149.11.11.11:

```
cn=149.11.11.11
```

If your network has a Domain Name System and you mapped a name to the IP address of a switch, you can specify the switch's name instead of the IP address as the distinguished name.

For those switches that do not have an IP address, such as slave switches of an enhanced stack, you could assign their certificates a distinguished name using the IP address of the master switch of the enhanced stack.

There is a benefit to giving a certificate a distinguished name equivalent to a switch's IP address or domain name. This relates to what happens when you start a web browser management session with a switch using SSL. The web browser on your management station checks to see if the name to whom the certificate was issued matches the name of the web site. In the case of the AT-9400 Switch, the web site's name is the switch's IP address or domain name or, in the case of an enhanced stack, the master switch's IP address. If the names do not match, the web browser displays a security warning. Of course, even if you see the security warning, you can close the warning prompt and still configure the switch using your web browser.

---

**Note**

If the certificate will be issued by a private or public CA, you should check with the CA to see if they have any rules or guidelines on distinguished names for the certificates they issue.

---

## SSL and Enhanced Stacking

---

Secure Sockets Layer (SSL) is supported in an enhanced stack, but only when all switches in the stack are using the feature.

When a switch's web server is operating in HTTP, management packets are transmitted in plaintext. When it operates in HTTPS, management packets are encrypted. The web server on the AT-9400 Switch operate in either mode. Enhanced stacking switches that do not support SSL, such as the AT-8000 Series switches, use HTTP exclusively.

A web browser management session of the switches in an enhanced stack cannot alternate between the different security modes during a session. The management session assumes that the web server mode that the master switch is using is the same for all the switches in the stack. As an example, if the master switch is using HTTPS, a web browser management session assumes that all the other switches in the stack are also using HTTPS, and it does not allow you to manage any switches running HTTP.

For those networks that consist of enhanced stacking switches where some switches support SSL and others do not, there are two approaches you can take. One is to create different enhanced stacks for the different switches, with one enhanced stack for those switches that support SSL and another for those that do not. You create different enhanced stacks by connecting the switches with different common VLANs.

Another workaround is to create one enhanced stack of all the switches and designate two master switches, where one master switch uses HTTP and the other HTTPS. When you need to manage those switches in the stack supporting SSL, you would start the management session on the master switch whose server mode is set to HTTPS. And when you want to manage those switch not supporting SSL, you would start the management session on the master switch whose web server is set to HTTP.

Each switch in a stack must have its own key pair and certificate. They cannot share keys and certificates. When you start a web browser management session on the master switch of an enhanced stack, the management session uses that switch's certificate and key pair. When you change to another switch in the stack, the management session starts to use the certificate and key pair on that switch, and so forth.

## Guidelines

---

The guidelines for creating certificates are:

- ❑ A certificate can have only one key.
- ❑ A switch can use only those certificates that contain a key that was generated on the switch.
- ❑ You can create multiple certificates on a switch, but the device uses the certificate whose key pair has been designated as the active key pair for the switch's web server.
- ❑ Most web browsers support both unsecured (plaintext) and secured (encrypted) operation. These modes are referred to as HTTP and HTTPS, respectively. If you choose to use encryption when you manage a switch, the web browser you use must support HTTPS.

## Technical Overview

---

This section describes the Secure Sockets Layer (SSL) feature, a security protocol that provides a secure and private TCP connection between a client and server.

SSL can be used with many higher layer protocols including HTTP, File Transfer Protocol (FTP) and Net News Transfer Protocol (NNTP). Most web browsers and servers support SSL, and its most common deployment is for secure connections between a client and server over the Internet.

The switch supports SSL versions 2.0 (client hello only) and 3.0 which were developed by Netscape, and the Internet Engineering Task Force (IETF) standard for SSL, known as SSL version 3.1 or Transport Layer Security (TLS).

Within the Ethernet protocol stack, SSL is a Layer 4 protocol that is in between the HTTP and TCP protocol layers. HTTP communicates with SSL in the same way as with TCP. In other words, TCP processes SSL requests like any other protocol requesting its services.

SSL provides a secure connection over which web pages can be accessed from an HTTP server. The operation of SSL is transparent to the end user who is accessing a web site with the following exceptions:

- ❑ The site's URL changes from HTTP to HTTPS.
- ❑ The browser indicates that it is a secured connection by displaying an icon, such as a padlock icon.

By default, HTTP and HTTPS use the separate well-known ports 80 and 443, respectively. Secure connections over the Internet are important when transmitting confidential data such as credit card details or passwords. SSL allows the client to verify the server's identity before either side sends any sensitive information. SSL also prevents a third party from interfering with the message because only trusted devices have access to the unprotected data.

### SSL Encryption

SSL uses *encryption* to ensure the security of data transmission. Encryption is a process that uses an algorithm to encode data so it can only be accessed by a trusted device. An encrypted message remains confidential.

All application data messages are authenticated by SSL with a *message authentication code* (MAC). The MAC is a checksum that is created by the sender and is sent as part of the encrypted message. The recipient recalculates the MAC, and if the values match, the sender's identity is verified. The MAC also ensures that the message has not been tampered with by a third party because any change to the message changes the MAC.

SSL uses *asymmetrical (Public Key)* encryption to establish a connection between client and server, and *symmetrical (Secret Key)* encryption for the data transfer phase.

## User Verification

An SSL connection has two phases: *handshake* and *data transfer*. The *handshake* initiates the *SSL session*, during which data is securely transmitted between a client and server. During the handshake, the following occurs:

- ❑ The client and server establish the SSL version they are to use.
- ❑ The client and server negotiate the *cipher suite* for the session, which includes encryption, authentication, and key exchange algorithms.
- ❑ The *symmetrical key* is exchanged.
- ❑ The client authenticates the server (optionally, the server authenticates the client).

SSL messages are encapsulated by the *Record Layer* before being passed to TCP for transmission. Four types of SSL messages exist, they are:

- ❑ Handshake
- ❑ Change Cipher Spec
- ❑ Alert
- ❑ Application data (HTTP, FTP or NNTP)

As discussed previously, the Handshake message initiates the SSL session.

The *Change Cipher Spec* message informs the receiving party that all subsequent messages are encrypted using previously negotiated security options. The parties use the strongest cryptographic systems that they both support.

The *Alert* message is used if the client or server detects an error. Alert messages also inform the other end that the session is about to close. In addition, the Alert message contains a severity rating and a description of the alert. For example, an alert message is sent if either party receives an invalid certificate or an unexpected message.

The *Application data* message encapsulates the encrypted application data.

## Authentication

Authentication is the process of ensuring that both the web site and the end user are genuine. In other words, they are not imposters. Both the server and an individual users need to be authenticated. This is especially important when transmitting secure data over the Internet.

To verify the authenticity of a server, the server has a public and private key. The public key is given to the user.

SSL uses *certificates* for authentication. A certificate binds a public key to a server name. A certification authority (CA) issues certificates after checking that a public key belongs to its claimed owner. There are several agencies that are trusted to issue certificates. Individual browsers have approved Root CAs that are built in to the browser.

## **Public Key Infrastructure**

The public key infrastructure (PKI) feature is part of the switch's suite of security modules, and consists of a set of tools for managing and using certificates. The tools that make up the PKI allow the switch to securely exchange public keys, while being sure of the identity of the key holder.

The switch acts as an End Entity (EE) in a certificate-based PKI. More specifically, the switch can communicate with Certification Authorities (CAs) and Certificate Repositories to request, retrieve and verify certificates. The switch allows protocols running on the switch, such as ISAKMP, access to these certificates. The following sections of this chapter summarize these concepts and describe the switch's implementation of them.

## **Public Keys**

Public key encryption involves the generation of two keys for each user, one private and one public. Material encrypted with a private key can only be decrypted with the corresponding public key, and vice versa. An individual's private key must be kept secret, but the public key may be distributed as widely as desired, because it is impossible to calculate the private key from the public key. The advantage of public key encryption is that the private key need never be exchanged, and so can be kept secure more easily than a shared secret key.

## **Message Encryption**

One of the two main services provided by public key encryption is the exchange of encrypted messages. For example, user 1 can send a secure message to user 2 by encrypting it with user 2's public key. Only user 2 can decrypt it, because only user 2 has access to the corresponding private key.

## **Digital Signatures**

The second main service provided by public key encryption is digital signing. Digital signatures both confirm the identity of the message's supposed sender and protect the message from tampering. Therefore they provide message authentication and non-repudiation. It is very difficult for the signer of a message to claim that the message was corrupted, or to deny that it was sent.

Both the exchange of encrypted messages and digital signatures are secure only if the public key used for encryption or decryption belongs to the message's expected recipient. If a public key is insecurely distributed, it is possible a malicious agent could intercept it and replace it with the malicious agent's public key (the Man-in-the-Middle attack). To prevent

this, and other attacks, PKI provides a means for secure transfer of public keys by linking an identity and that identity's public key in a secure certificate.



### Caution

Although a certificate binds a public key to a subject to ensure the public key's security, it does not guarantee that the security of the associated private key has not been breached. A secure system is dependent upon private keys being kept secret, by protecting them from malicious physical and virtual access.

## Certificates

A *certificate* is an electronic identity document. To create a certificate for a subject, a trusted third party (known as the Certification Authority) verifies the subject's identity, binds a public key to that identity, and digitally signs the certificate. A person receiving a copy of the certificate can verify the Certification Authority's digital signature and be sure that the public key is owned by the identity in it.

The switch can generate a self-signed certificate but this should only be used with an SSL enabled HTTP server, or where third party trust is not required.

### X.509 Certificates

The X.509 specification specifies a format for certificates. Almost all certificates use the X.509 version 3 format, described in RFC 2459, *Internet X.509 Public Key Infrastructure Certificate and CRL Profile*. This is the format which is supported by the switch.

An X.509 v3 certificate consists of:

- A serial number, which distinguishes the certificate from all others issued by that issuer. This serial number is used to identify the certificate in a Certificate Revocation List, if necessary.
- The owner's identity details, such as name, company and address.
- The owner's public key, and information about the algorithm with which it was produced.
- The identity details of the organization which issued the certificate.
- The issuer's digital signature and the algorithm used to produce it.
- The period for which the certificate is valid.
- Optional information is included, such as the type of application with which the certificate is intended to be used.

The issuing organization's digital signature is included in order to authenticate the certificate. As a result, if a certificate is tampered with during transmission, the tampering is detected.



## **Elements of a Public Key Infrastructure**

A public key infrastructure is a set of applications which manage the creation, retrieval, validation and storage of certificates. A PKI consists of the following key elements:

- ❑ At least one certification authority (CA), which issues and revokes certificates.
- ❑ At least one publicly accessible repository, which stores certificates and Certificate Revocation Lists.
- ❑ At least one end entity (EE), which retrieves certificates from the repository, validates them and uses them.

### **End Entities (EE)**

End entities own public keys and may use them for encryption and digital signing. An entity which uses its private key to digitally sign certificates is not considered to be an end entity, but is a certification authority.

The switch acts as an end entity.

### **Certification Authorities**

A certification authority is an entity which issues, updates, revokes and otherwise manages public keys and their certificates. A CA receives requests for certification, validates the requester's identity according to the CA's requirements, and issues the certificate, signed with one of the CA's keys. CAs may also perform the functions of end entities, in that they may make use of other CAs' certificates for message encryption and verification of digital signatures.

An organization may own a certification authority and issue certificates for use within its own networks. In addition, an organization's certificates may be accepted by another network, after an exchange of certificates has validated a certificate for use by both parties. As an alternative, an outside CA may be used. The switch can interact with the CA, whether a CA is part of the organization or not, by sending the CA requests for certification.

The usefulness of certificates depends on how much you trust the source of the certificate. You must be able to trust the issuing CA to verify identities reliably. The level of verification required in a given situation depends on the organization's security needs.

## **Certificate Validation**

To validate a certificate, the end entity verifies the signature in the certificate, using the public key of the CA who issued the certificate.

### **CA Hierarchies and Certificate Chains**

It may not be practical for every individual certificate in an organization to be signed by one certification authority. A certification hierarchy may be formed, in which one CA (for example, national headquarters) is declared to be the root CA. This CA issues certificates to the next level down in the hierarchy (for example, regional headquarters), who become subordinate CAs and issue certificates to the next level down, and so on. A hierarchy may have as many levels as needed.

Certificate hierarchies allow validation of certificates through certificate chains and cross-certification. If a switch X, which holds a certificate signed by CA X, wishes to communicate securely with a switch Y, which holds a certificate signed by CA Y, there are two ways in which the switches can validate each other's certificates. Cross-certification occurs when switch X validates switch Y's CA (CA Y) by obtaining a certificate for switch Y's CA which has been issued by its own CA (CA X). A certificate chain is formed if both CA X and CA Y hold a certificate signed by a root CA Z, which the switches have verified out of band. Switch X can validate switch Y's certificate (and vice versa) by following the chain up to CA Z.

### **Root CA Certificates**

A root CA must sign its own certificate. The root CA is the most critical link in the certification chain, because the validity of all certificates issued by any CA in the hierarchy depends on the root CA's validity. Therefore, every device which uses the root CA's certificate must verify it out-of-band.

Out-of-band verification involves both the owner of a certificate and the user who wishes to verify that certificate generating a one-way hash (a fingerprint) of the certificate. These two hashes must then be compared using at least one non-network-based communication method. Examples of suitable communication methods are mail, telephone, fax, or transfer by hand from a storage device such as a smart card or floppy disk. If the two hashes are the same, the certificate can be considered valid.

## **Certificate Revocation Lists (CRLs)**

A certificate may become invalid because some of the details in it change (for example, the address changes), because the relationship between the Certification Authority (CA) and the subject changes (for example, an employee leaves a company), or because the associated private key is compromised. Every CA is required to keep a publicly accessible list of its certificates which have been revoked.

## **PKI Implementation**

The following sections discuss the implementation of PKI on the AT-9400 Switch. The following topics are covered:

- ❑ PKI Standards
- ❑ Certificate Retrieval and Storage
- ❑ Certificate Validation
- ❑ Root CA Certificates

### **PKI Standards**

The following standards are supported by the switch:

- ❑ draft-ietf-pkix-roadmap-05 — *PKIX Roadmap*
- ❑ RFC 1779 — *A String Representation of Distinguished Names*
- ❑ RFC 2459 — *PKIX Certificate and CRL Profile*
- ❑ RFC 2511 — *PKIX Certificate Request Message Format*
- ❑ PKCS #10 v1.7 — *Certification Request Syntax Standard*

### **Certificate Retrieval and Storage**

Certificates are stored by CAs in publicly accessible repositories for retrieval by end entities. The following repositories used in PKI are commonly accessed via the following protocols: *Hypertext Transfer Protocol (HTTP)*, *File Transfer Protocol (FTP)*.

Before the switch can use a certificate, it must be retrieved and manually added to the switch's certificate database, which is stored in RAM memory. The switch attempts to validate the certificate, and if validation is successful the certificate's public key is available for use.

### **Root CA Certificate Validation**

Root CA certificates are verified out of band by comparing the certificate's *fingerprint* (the encrypted one-way hash with which the issuing CA signs the certificate) with the fingerprint which the CA has supplied by a non-network-based method.



## Chapter 37

# Secure Shell (SSH)

---

The sections in this chapter are:

- ❑ “Supported Platforms” on page 438
- ❑ “Overview” on page 439
- ❑ “Support for SSH” on page 440
- ❑ “SSH Server” on page 441
- ❑ “SSH Clients” on page 442
- ❑ “SSH and Enhanced Stacking” on page 443
- ❑ “SSH Configuration Guidelines” on page 445
- ❑ “General Steps to Configuring SSH” on page 446

## Supported Platforms

---

Refer to Table 110 and Table 111 for the AT-9400 Switches and the management interfaces that support the Secure Shell protocol.

Table 110. Support for the Secure Shell Protocol

Switch	Supported
Layer 2+ Models	
AT-9408LC/SP	Yes
AT-9424T/GB	Yes
AT-9424T/SP	Yes
Basic Layer 3 Models	
AT-9424T	Yes
AT-9424T/POE	Yes
AT-9424Ts	Yes
AT-9424Ts/XP	Yes
AT-9448T/SP	Yes
AT-9448Ts/XP	Yes
AT-9400Ts Stack	Yes

Table 111. Management Interfaces for the Secure Shell Protocol

Switch or Stack	Standard Command Line	AlliedWare Plus Command Line	Menus	Web Browser
Stand-alone Switch	Yes	Yes	Yes	Yes
AT-9400Ts Stack	Yes	Yes		

## Overview

---

Secure management is increasingly important in modern networks, as the ability to easily and effectively manage switches and the requirement for security are two universal requirements. Switches are often remotely managed using remote sessions via the Telnet protocol. This method, however, has a serious security problem—it is only protected by plaintext usernames and passwords which are vulnerable to wiretapping and password guessing.

The Secure Shell (SSH) protocol provides encrypted and strongly authenticated remote login sessions, similar to the Telnet and rlogin protocols, between a host running a Secure Shell server and a machine with a Secure Shell client.

The AT-S63 Management Software features Secure Shell server software so that network managers can securely manage the switch over an insecure network. It offers the benefit of cryptographic authentication and encryption. Secure Shell can replace Telnet for remote management sessions.

## Support for SSH

---

The AT-S63 implementation of the SSH protocol is compliant with the SSH protocol versions 1.3, 1.5, and 2.0.

In addition, the following SSH options and features are supported:

- ❑ Inbound SSH connections (server mode) is supported.
- ❑ The following security algorithms are supported:
  - 128-bit Advanced Encryption Standard (AES), 192-bit AES, and 256-bit AES
  - Arcfour (RC4) security algorithm is supported.
  - Triple-DES (3DES) encryption for SSH sessions is supported.
- ❑ RSA public keys with lengths of 512 to 2048 bits are supported. Keys are stored in a format compatible with other Secure Shell implementations, and mechanisms are provided to copy keys to and from the switch.
- ❑ Compression of SSH traffic.

The following SSH options and features are **not** supported:

- ❑ IDEA or Blowfish encryption
- ❑ Nonencrypted Secure Shell sessions
- ❑ Tunnelling of TCP/IP traffic

---

### **Note**

Non-encrypted Secure Shell sessions serve no purpose.

---



## SSH Server

---

When the SSH server is enabled, connections from SSH clients are accepted. When the SSH server is disabled, connections from SSH clients are rejected by the switch. Within the switch, the AT-S63 Management Software uses well-known port 22 as the SSH default port.

---

**Note**

If your switch is in a network that is protected by a firewall, you may need to configure the firewall to permit SSH connections.

---

The SSH server accepts connections from configured users only. Acceptable users are those with a Manager or Operator login as well as users configured with the RADIUS and TACACS+ protocols. You can add, delete, and modify users with the RADIUS and TACACS+ feature.

SSH encryption key management is implemented by the Encryption (ENCO) protocol. For information on how to create encryption keys, see Chapter 35, “Encryption Keys” on page 411.

## SSH Clients

---

The SSH protocol provides a secure connection between the switch and SSH clients. After you have configured the SSH server, you need to install SSH client software on your management workstations. The AT-S63 Management Software supports both SSH1 and SSH2 clients.

You can download client software from the Internet. Two popular SSH clients are PuTTY and CYGWIN. To install SSH client software, follow the directions from the vendor.

## SSH and Enhanced Stacking

The AT-S63 Management Software allows for encrypted SSH management sessions between a management station and a master switch of an enhanced stack, but not with slave switches, as explained in this section.

When you remotely manage a slave switch, all management communications are conducted through the master switch using the enhanced stacking feature. Management packets from your workstation are first directed to the master switch before being forwarded to the slave switch. The reverse is true as well. Management packets from a slave switch first pass through the master switch before reaching your management station.

Enhanced stacking uses a proprietary protocol different from Telnet and SSH protocols. Consequently, there is no encryption between a master switch and a slave switch. The result is that SSH encryption only occurs between your workstation and the master switch, not between your workstation and a slave switch.

This is illustrated in Figure 47. The figure shows an SSH management station that is managing a slave switch of an enhanced stack. The packets exchanged between the slave switch and the master switch are transmitted in plaintext and those exchanged between the master switch and the SSH management station are encrypted

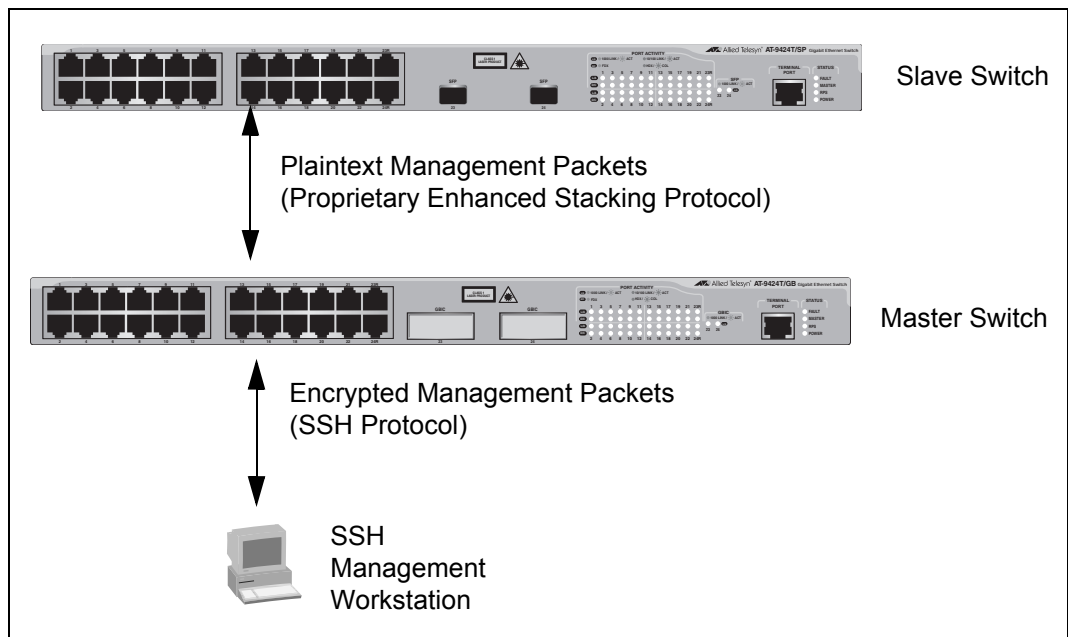

Figure 47 SSH Remote Management of a Slave Switch

Because enhanced stacking does not allow for SSH encrypted management sessions between a management station and a slave switch, you configure SSH only on the master switch of a stack. Activating SSH on a slave switch has no affect.

## SSH Configuration Guidelines

---

Here are the guidelines to configuring SSH:

- ❑ SSH requires two encryption key pairs. One key pair functions as the host key and the other as the server key.
- ❑ The two encryption key pairs must be of different lengths of at least one increment (256 bits) apart. The recommended bit size for a server key is 768 bits. The recommended size for the host key is 1024 bits.
- ❑ You activate and configure SSH on the master switch of an enhanced stack, not on slave switches.
- ❑ The AT-S63 software uses well-known port 22 as the SSH default port.

## General Steps to Configuring SSH

---

Configuring the SSH server involves the following procedures:

1. Create two encryption key pairs on the switch. One pair will function as the host key and the other the server key.
2. Configure and activate the Secure Shell server on the switch by specifying the two encryption keys in the server software.
3. Install SSH client software on your management station.

Follow the directions provided with the client software. You can download SSH client software from the Internet. Two popular SSH clients are PuTTY and CYGWIN.

4. Disable the Telnet server.

Although the switch allows the SSH and Telnet servers to be enabled simultaneously, allowing Telnet to be enabled negates the security of the SSH feature.

5. Log in to from your SSH management station using the IP address of the local interface on the switch.

## Chapter 38

# TACACS+ and RADIUS Protocols

---

This chapter describes the two authentication protocols TACACS+ and RADIUS. Sections in the chapter include:

- ❑ “Supported Platforms” on page 448
- ❑ “Overview” on page 449
- ❑ “Guidelines” on page 451

## Supported Platforms

---

Refer to Table 112 and Table 113 for the AT-9400 Switches and the management interfaces that support the TACACS+ and RADIUS protocols.

Table 112. Support for the TACACS+ and RADIUS Protocols

Switch	Supported
Layer 2+ Models	
AT-9408LC/SP	Yes
AT-9424T/GB	Yes
AT-9424T/SP	Yes
Basic Layer 3 Models	
AT-9424T	Yes
AT-9424T/POE	Yes
AT-9424Ts	Yes
AT-9424Ts/XP	Yes
AT-9448T/SP	Yes
AT-9448Ts/XP	Yes
AT-9400Ts Stack	Yes <sup>1</sup>

1. Stacks do not support the TACACS+ protocol.

Table 113. Management Interfaces for the TACACS+ and RADIUS Protocols

Switch or Stack	Standard Command Line	AlliedWare Plus Command Line	Menus	Web Browser
Stand-alone Switch	Yes	Yes	Yes	Yes
AT-9400Ts Stack	Yes	Yes		Yes <sup>1</sup>

1. You can use the web browser interface to configure RADIUS accounting on a stack, but you cannot use the interface to enter the IP addresses of the RADIUS servers.



## Overview

---

TACACS+ and RADIUS are authentication protocols that can enhance the manageability of your network. In general terms, these authentication protocols transfer the task of authenticating network access from a network device to an authentication protocol server.

The AT-S63 software comes with TACACS+ and RADIUS client software. You can use the client software to add two security features to the switch. The first feature, described in this chapter, creates new manager accounts for controlling who can log onto a switch to change its parameter settings. The second feature is 802.1x Port-based Access Control, explained in Chapter 33, “802.1x Port-based Network Access Control” on page 379, which controls access to the ports on the switch by the end users and end nodes.

This chapter explains the manager accounts feature. The AT-S63 Management Software has two standard manager login accounts: manager and operator. The manager account lets you change a switch’s parameter settings while the operator account lets you view the settings, but not change them. Each account has its own password. The manager account has a default password of “friend” and the operator account has a default password “operator.”

For those networks managed by just one or two network managers, you might not need any additional accounts. However, for larger networks that are managed by several network managers, you might want to give the managers their own management login accounts on the switches rather than have them share accounts.

This is where TACACS+ and RADIUS can be useful. TACACS+ is an acronym for Terminal Access Controller Access Control System. RADIUS is an acronym for Remote Authentication Dial In User Services. These are authentication protocols. You can use protocols to transfer the task of validating management access from the AT-9400 Switch to an authentication protocol server, and so be able to create your own manager accounts.

With these protocols you can create a series of username and password combinations that define who can manage the AT-9400 Switch.

There are three basic functions an authentication protocol provides:

- Authentication
- Authorization
- Accounting

When a network manager logs in to a switch to manage the device, the switch passes the username and password entered by the manager to the authentication protocol server. The server checks to see if the username and password are valid. This is referred to as authentication.

If the combination is valid, the authentication protocol server notifies the switch and the switch completes the login process, allowing the manager to manage the switch.

If the username and password are invalid, the authentication protocol server notifies the switch and the switch cancels the login.

Authorization defines what a manager can do after logging in to a switch. The AT-9400 Switch supports two management levels, Manager and Operator. The Manager level lets you view and configure a switch's parameter settings, while the Operator level only lets you view the settings. You must assign an authorization level to each manager username and password combination on the authentication server.

The final function of an authentication protocol is keeping track of user activity on network devices, referred to as accounting. The AT-S63 Management Software does not support RADIUS or TACACS+ accounting as part of manager accounts. However, it does support RADIUS accounting with the 802.1x Port-based Network Access Control feature, as explained in Chapter 33, "802.1x Port-based Network Access Control" on page 379.

---

**Note**

The AT-S63 Management Software does not support the two earlier versions of the TACACS+ protocol, TACACS and XTACACS.

---

## Guidelines

---

Here are the main steps to using the TACACS+ or RADIUS client on the switch.

1. Install a TACACS+ or RADIUS server on one or more of your network servers or management stations. Authentication protocol server software is not available from Allied Telesis.
2. Configure the TACACS+ or RADIUS authentication server.

Here are the guidelines to follow when configuring the server for new manager accounts:

- To create a new manager account, enter the username and password combination that the network manager will use to log onto the switch when managing the device. The maximum length for a username is 38 alphanumeric characters and spaces, and the maximum length for a password is 16 alphanumeric characters and spaces.
- You must assign each account an authorization level. This differs depending on the server software. TACACS+ controls this through the sixteen (0 to 15) different levels of the Privilege attribute. A privilege level of “0” gives the combination Operator status. Any value from 1 to 15 gives the combination Manager status.

For RADIUS, management level is controlled by the Service Type attribute. This attribute has 11 different values; only two apply to the AT-S63 Management Software. A value of Administrative for this attribute gives the username and password combination Manager access. A value of NAS Prompt assigns the combination Operator status.

---

### Note

This manual does not explain how to configure a TACACS+ or RADIUS server. For instructions, refer to the documentation included with the server software.

---

Here are the guidelines to follow when configuring the server for supplicant accounts for 802.1x port-based access control:

- 802.1x is only supported with a RADIUS server.
- To create an account for a supplicant connected to an authenticator port set to the 802.1x authentication mode, enter a username and password combination. The maximum length for a username is 38 alphanumeric characters and spaces, and the

maximum length for a password is 16 alphanumeric characters and spaces.

- To create an account for a supplicant connected to an authenticator port set to the MAC address-based authentication mode, enter the MAC address of the node used by the supplicant as both its username and password. When entering the MAC address, do not use spaces or colons (:).
  - If you are associating VLANs with supplicant accounts, refer to “Supplicant VLAN Attributes on the RADIUS Server” on page 395 for further information.
3. Configure the TACACS+ or RADIUS client on the switch by entering the IP addresses of up to three authentication servers.
  4. Activate the TACACS+ or RADIUS client on the switch.

The switch must have a routing interface on the local subnet where the TACACS+ or RADIUS server is a member. The switch uses the routing interface’s IP address as its source address when communicating with the server. For background information on routing interfaces, refer to Chapter 29, “Internet Protocol Version 4 Packet Routing” on page 321.

---

**Note**

Prior to version 2.0.0 of the AT-S63 Management Software, TACACS+ or RADIUS server had to be a member of the switch’s management VLAN. This restriction no longer applies. The server can be located on any local subnet that has a routing interface.

---

By default, authentication protocol is disabled in the AT-S63 Management Software. Before activating it, you need the following information:

- Select either TACACS+ or RADIUS as the active authentication protocol. Only one authentication protocol can be active on a switch at a time.
- Specify the IP addresses of up to three authentication servers.
- Specify the encryption keys used by the authentication servers.

You can specify up to three RADIUS or TACACS+ servers. Specifying multiple servers adds redundancy to your network. For example, removing an authentication server from the network for maintenance does not prevent network managers from logging into switches if there are one or two other authentication servers on the network.

When a switch receives a username and password combination from a network manager, it sends the combination to the first authentication server in its list. If the server fails to respond, the switch sends the combination to the next server in the list, and so on.

---

**Note**

If no authentication server responds or if no servers have been defined, the AT-S63 Management Software defaults to the standard manager and operator accounts.

---

---

**Note**

For more information on TACACS+, refer to the RFC 1492 standard. For more information on RADIUS, refer to the RFC 2865 standard.

---



## Chapter 39

# Management Access Control List

---

This chapter explains how to restrict Telnet and web browser management access to the switch with the management access control list (ACL).

Sections in this chapter include:

- ❑ “Supported Platforms” on page 456
- ❑ “Overview” on page 457
- ❑ “Parts of a Management ACE” on page 458
- ❑ “Guidelines” on page 459
- ❑ “Examples” on page 460

## Supported Platforms

---

Refer to Table 114 and Table 115 for the AT-9400 Switches and the management interfaces that support the management access control list.

Table 114. Support for the Management Access Control List

Switch	Supported
Layer 2+ Models	
AT-9408LC/SP	Yes
AT-9424T/GB	Yes
AT-9424T/SP	Yes
Basic Layer 3 Models	
AT-9424T	Yes
AT-9424T/POE	Yes
AT-9424Ts	Yes
AT-9424Ts/XP	Yes
AT-9448T/SP	Yes
AT-9448Ts/XP	Yes
AT-9400Ts Stack	

Table 115. Management Interfaces for the Management Access Control List

Switch or Stack	Standard Command Line	AlliedWare Plus Command Line	Menus	Web Browser
Stand-alone Switch	Yes		Yes	Yes
AT-9400Ts Stack				



## Overview

---

This chapter explains how to restrict remote management access of a switch by creating a management access control list (management ACL). This feature controls which management stations can remotely manage the device using the Telnet application protocol or a web browser.

The switch uses the management ACL to filter the management packets that it receives. The switch accepts and processes only those management packets that meet the criteria stated in the ACL. Those management packets that do not meet the criteria are discarded.

The benefit of this feature is that you can prevent unauthorized access to the switch by controlling which workstations are to have remote management access. You can even control which method, Telnet or web browser, that a remote manager can use.

For example, you can create a management ACL that allows the switch to accept management packets only from the management stations in one subnet or from just one or two specific management stations.

An access control list (ACL) is a list of one or more statements that define which management packets the switch accepts. Each statement, referred to as an access control entry (ACE), contains criteria that the switch uses in making the determination.

An ACE in a management ACL is an implicit “permit” statement. This means that a management packet that meets the criteria of an ACE is processed by the switch. Consequently, the ACEs that you enter into the management ACL should specify which management packets you want the switch to process. Packets that do not meet any of the ACEs in the management ACL are discarded.

## Parts of a Management ACE

---

An ACE has the following three parts:

- IP address
- Subnet mask
- Application

**IP Address** You can specify the IP address of a specific management station or a subnet.

**Mask** The mask indicates the parts of the IP address the switch should filter on. A binary “1” indicates the switch should filter on the corresponding bit of the address, while a “0” indicates that it should not. If you are filtering on a specific IP address, use the mask 255.255.255.255. If you are filtering on a subnet, the mask would depend on the address. For example, to allow all management stations in the subnet 149.11.11.0 to manage the switch, you would enter the mask 255.255.255.0.

**Application** The application parameter allows you control whether the remote management station can manage the switch using Telnet, a web browser, or both. For example, you might create an ACE that states that a particular remote management station can only use a web browser to manage the switch. You can also use this option to control whether the management station can ping the switch.

## Guidelines

---

Below are guidelines for the management ACL:

- ❑ The default setting for this feature is disabled.
- ❑ A switch can have only one management ACL.
- ❑ A management ACL can have up to 256 ACEs.
- ❑ An ACE must have an IP address and mask.
- ❑ All management ACEs are implicit “permit” statements. A management packet that meets the criteria of an ACE is accepted by the switch. Consequently, the ACEs you enter into the management ACL should specify which management packets you want the switch to process. Management packets that do not meet any of the ACEs in the management ACL are discarded.
- ❑ A management packet that meets an ACE is immediately processed by the switch and is not compared against any remaining ACEs in the management ACL.
- ❑ The ACEs are performed in the order of their identification number, starting with 1.
- ❑ The management ACL does not control local management or remote SSH or SNMP management of a switch.
- ❑ Activating this feature without specifying any ACEs prohibits you from managing the switch remotely using a Telnet application or web browser because the switch discards all Telnet and web browser management packets.
- ❑ You can apply management ACLs to both master and slave switches in an enhanced stack. A management ACL on a master switch filters management packets intended for the master switch as well as those intended for any slave switches that you manage through the master switch. A management ACL applied to a slave switch filters only those management packets directed to the slave switch.

## Examples

---

Following are several examples of ACEs.

This ACE allows the management station with the IP address 149.11.11.11 to remotely manage the switch using either the Telnet application protocol or a web browser, and to ping the device:

```
IP Address:      149.11.11.11
Mask:           255.255.255.255
Application Type: All
```

If the management ACL had only this ACE, remote management of the switch would be restricted to just that management station.

This ACE permits remote Telnet and web browser management of the switch from all management stations in the subnet 149.11.11.0. It also permits the management stations to ping the switch:

```
IP Address:      149.11.11.0
Mask:           255.255.255.0
Application Type: All
```

This ACE permits remote web browser management of the switch from the subnet 149.11.11.0. The management workstations can also ping the device. However, since this ACE does not include Telnet management as an application type, that form of management is not permitted:

```
IP Address:      149.11.11.0
Mask:           255.255.255.0
Application Type: Web, Ping
```

A management ACL can contain multiple ACEs. The two ACEs in the next example allow for remote Telnet management from the subnets 149.11.11.0 and 149.22.22.0. Web browser management and pinging the device are not permitted:

### ACE #1

```
IP Address:      149.11.11.0
Subnet Mask:     255.255.255.0
Application Type: Telnet
```

### ACE #2

```
IP Address:      149.22.22.0
Subnet Mask:     255.255.255.0
Application Type: Telnet
```

The two ACEs in this management ACL permit remote management from the management station with the IP address 149.11.11.11 and all management stations in the subnet 149.22.22.0:

ACE #1

IP Address: 149.11.11.11  
Mask: 255.255.255.255  
Application Type: All

ACE #2

IP Address: 149.22.22.0  
Mask: 255.255.255.0  
Application Type: All

This example allows the switch to be pinged, but not managed, by the management station with the IP address 149.11.11.4:

IP Address: 149.11.11.4  
Mask: 255.255.255.255  
Application Type: Ping



## Appendix A

# AT-S63 Management Software Default Settings

---

This appendix lists the factory default settings for the AT-S63 Management Software. The features are listed in alphabetical order:

- ❑ “Address Resolution Protocol Cache” on page 465
- ❑ “Boot Configuration File” on page 466
- ❑ “BOOTP Relay Agent” on page 467
- ❑ “Class of Service” on page 468
- ❑ “Denial of Service Defenses” on page 469
- ❑ “802.1x Port-Based Network Access Control” on page 470
- ❑ “Enhanced Stacking” on page 472
- ❑ “Ethernet Protection Switching Ring (EPSR) Snooping” on page 473
- ❑ “Event Logs” on page 474
- ❑ “GVRP” on page 475
- ❑ “IGMP Snooping” on page 476
- ❑ “Internet Protocol Version 4 Packet Routing” on page 477
- ❑ “MAC Address-based Port Security” on page 478
- ❑ “MAC Address Table” on page 479
- ❑ “Management Access Control List” on page 480
- ❑ “Manager and Operator Account” on page 481
- ❑ “Multicast Listener Discovery Snooping” on page 482
- ❑ “Public Key Infrastructure” on page 483
- ❑ “Port Settings” on page 484
- ❑ “RJ-45 Serial Terminal Port” on page 485
- ❑ “Router Redundancy Protocol Snooping” on page 486
- ❑ “Server-based Authentication (RADIUS and TACACS+)” on page 487
- ❑ “Simple Network Management Protocol” on page 488
- ❑ “Simple Network Time Protocol” on page 489
- ❑ “Spanning Tree Protocols (STP, RSTP, and MSTP)” on page 490
- ❑ “Secure Shell Server” on page 492
- ❑ “Secure Sockets Layer” on page 493
- ❑ “System Name, Administrator, and Comments Settings” on page 494

- ❑ “Telnet Server” on page 495
- ❑ “Virtual Router Redundancy Protocol” on page 496
- ❑ “VLANs” on page 497
- ❑ “Web Server” on page 498



## Address Resolution Protocol Cache

---

The following table lists the ARP cache default setting.

<b>ARP Cache Setting</b>	<b>Default</b>
ARP Cache Timeout	150 seconds

## Boot Configuration File

---

The following table lists the names of the default configuration files.

<b>Boot Configuration File</b>	<b>Default</b>
Stand-alone Switch	boot.cfg
Stack of AT-9400 Basic Layer 3 Switches and the AT-StackXG Stacking Module	stack.cfg

## BOOTP Relay Agent

---

The following table lists the default setting for the BOOTP relay agent.

<b>BOOTP Relay Agent Setting</b>	<b>Default</b>
Status	Disabled
Hop Count <sup>1</sup>	4

1. Hop count is not adjustable.

## Class of Service

---

The following table lists the default mappings of IEEE 802.1p priority levels to egress port priority queues.

<b>IEEE 802.1p Priority Level</b>	<b>Port Priority Queue</b>
0	Q1
1	Q0 (lowest)
2	Q2
3	Q3
4	Q4
5	Q5
6	Q6
7	Q7 (highest)

## Denial of Service Defenses

---

The following table lists the default settings for the Denial of Service prevention feature.

<b>Denial of Service Prevention Setting</b>	<b>Default</b>
IP Address	0.0.0.0
Subnet Mask	0.0.0.0
Uplink Port	Highest numbered existing port
SYN Flood Defense	Disabled
Smurf Defense	Disabled
Land Defense	Disabled
Teardrop Defense	Disabled
Ping of Death Defense	Disabled
IP Options Defense	Disabled

## 802.1x Port-Based Network Access Control

---

The following table describes the 802.1x Port-based Network Access Control default settings.

<b>802.1x Port-based Network Access Control Settings</b>	<b>Default</b>
Port Access Control	Disabled
Authentication Method	RADIUS EAP
Port Role	None

The following table lists the default settings for RADIUS accounting.

<b>RADIUS Accounting Settings</b>	<b>Default</b>
Status	Disabled
Port	1813
Type	Network
Trigger Type	Start_Stop
Update Status	Disabled
Update Interval	60

The following table lists the default settings for an authenticator port.

<b>Authenticator Port Setting</b>	<b>Default</b>
Authentication Mode	802.1x
Supplicant Mode	Single
Port Control	Auto
Quiet Period	60 seconds
TX Period	30 seconds
Reauth Enabled	Enabled
Reauth Period	3600 seconds
Supplicant Timeout	30 seconds
Server Timeout	30 seconds
Max Requests	2

<b>Authenticator Port Setting</b>	<b>Default</b>
VLAN Assignment	Enabled
Secure VLAN	On
Control Direction	Both
Piggyback Mode	Disabled
Guest VLAN	None

The following table lists the default settings for a supplicant port.

<b>Supplicant Port Setting</b>	<b>Default</b>
Auth Period	30 seconds
Held Period	60 seconds
Max Start	3
Start Period	30 seconds
User Name	(none)
User Password	(none)

## Enhanced Stacking

---

The following table lists the enhanced stacking default setting.

<b>Enhanced Stacking Setting</b>	<b>Default</b>
Switch State	Slave



## Ethernet Protection Switching Ring (EPSR) Snooping

---

The following table lists the EPSR default setting.

<b>EPSR Setting</b>	<b>Default</b>
EPSR State	Disabled

## Event Logs

---

The following table lists the default settings for both the permanent and temporary event logs.

<b>Event Log Setting</b>	<b>Default</b>
Status	Enabled
Full Log Action	Wrap

## GVRP

---

This section provides the default settings for GVRP.

<b>GVRP Setting</b>	<b>Default</b>
Status	Disabled
GIP Status	Enabled
Join Timer	20 centiseconds
Leave Timer	60 centiseconds
Leave All Timer	1000 centiseconds
Port Mode	Normal

## IGMP Snooping

---

The following table lists the IGMP Snooping default settings.

<b>IGMP Snooping Setting</b>	<b>Default</b>
IGMP Snooping Status	Disabled
Multicast Host Topology	Single Host/ Port (Edge)
Host/Router Timeout Interval	260 seconds
Maximum IGMP Multicast Groups	64
Multicast Router Ports Mode	Auto Detect

## Internet Protocol Version 4 Packet Routing

---

The following table lists the IPv4 packet routing default settings.

Packet Routing Setting	Default
Equal Cost Multi-path (ECMP)	Enabled
Default Route	None
Update Timer	30 seconds
Invalid Timer	180 seconds
Split Horizon	Enabled
Split Horizon with Poison Reverse	Disabled
Autosummarization of Routes	Disabled

---

**Note**

The update and invalid timers are not adjustable. The switch does not support the IPv4 routing holddown and flush timers.

---

## MAC Address-based Port Security

---

The following table lists the MAC address-based port security default settings.

<b>MAC Address-based Port Security Setting</b>	<b>Default</b>
Security Mode	Automatic (no security)
Intrusion Action	Discard
Participating	No
MAC Limit	No Limit

## MAC Address Table

---

The following table lists the default setting for the MAC address table.

<b>MAC Address Table Setting</b>	<b>Default</b>
MAC Address Aging Time	300 seconds

## Management Access Control List

---

The following table lists the default setting for the management access control list.

<b>Management ACL Setting</b>	<b>Default</b>
Status	Disabled



## Manager and Operator Account

---

The following table lists the manager and operator account default settings.

<b>Manager Account Setting</b>	<b>Default</b>
Manager Login Name	manager
Manager Password	friend
Operator Login Name	operator
Operator Password	operator
Console Disconnect Timer Interval	10 minutes
Console Startup Mode	CLI

---

**Note**

Login names and passwords are case sensitive.

---

## Multicast Listener Discovery Snooping

---

The following table lists the MLD Snooping default settings.

<b>MLD Snooping Setting</b>	<b>Default</b>
MLD Snooping Status	Disabled
Multicast Host Topology	Single Host/ Port (Edge)
Host/Router Timeout Interval	260 seconds
Maximum MLD Multicast Groups	64
Multicast Router Ports Mode	Auto Detect

## Public Key Infrastructure

---

The following table lists the PKI default settings, including the generate enrollment request settings.

<b>PKI Setting</b>	<b>Default</b>
Switch Distinguished Name	None
Maximum Number of Certificates	256
Request Name	None
Key Pair ID	0
Format	PEM
Type	PKCS10

## Port Settings

---

The following table lists the port configuration default settings.

<b>Port Configuration Setting</b>	<b>Default</b>
Status	Enabled
10/100/1000Base-T Speed	Auto-Negotiation
Duplex Mode	Auto-Negotiation
MDI/MDI-X	Auto-MDI/MDIX
Packet Filtering	Disabled
Packet Rate Limiting	Disabled
Override Priority	No override
Head of Line Blocking Threshold	682 cells
Back Pressure	Disabled
Back Pressure Threshold	7,935 cells
Flow Control	Auto
Flow Control Threshold	7,935 cells

## RJ-45 Serial Terminal Port

---

The following table lists the RJ-45 serial terminal port default settings.

<b>RJ-45 Serial Terminal Port Setting</b>	<b>Default</b>
Data Bits	8
Stop Bits	1
Parity	None
Flow Control	None
Baud Rate	9600 bps

The baud rate is the only adjustable parameter on the port.

## Router Redundancy Protocol Snooping

---

The following table lists the RRP Snooping default setting.

<b>RRP Snooping Setting</b>	<b>Default</b>
RRP Snooping Status	Disabled

## Server-based Authentication (RADIUS and TACACS+)

---

This section describes the server-based authentication, RADIUS, and TACACS+ client default settings.

### Server-based Authentication

The following table describes the server-based authentication default settings.

Server-based Authentication Setting	Default
Server-based Authentication	Disabled
Active Authentication Method	TACACS+

### RADIUS Client

The following table lists the RADIUS configuration default settings.

RADIUS Configuration Setting	Default
Global Encryption Key	ATI
Global Server Timeout Period	30 seconds
RADIUS Server 1 Configuration	0.0.0.0
RADIUS Server 2 Configuration	0.0.0.0
RADIUS Server 3 Configuration	0.0.0.0
Auth Port	1812
Encryption Key	Not Defined

### TACACS+ Client

The following table lists the TACACS+ client configuration default settings.

TACACS+ Client Configuration Setting	Default
TAC Server 1	0.0.0.0
TAC Server 2	0.0.0.0
TAC Server 3	0.0.0.0
TAC Global Secret	None
TAC Timeout	30 seconds

## Simple Network Management Protocol

---

The following table describes the SNMP default settings.

<b>SNMP Communities Setting</b>	<b>Default</b>
SNMP Status	Disabled
Authentication Failure Trap Status	Disabled
Community Name	public (Read only)
Community Name	private (Read Write)
Status (public)	Enabled
Status (private)	Enabled
Open Status (public)	No
Open Status (private)	No



## Simple Network Time Protocol

---

The following table lists the SNTP default settings.

<b>SNTP Setting</b>	<b>Default</b>
System Time	00:00:00 on January 1, 1980
SNTP Status	Disabled
SNTP Server	0.0.0.0
UTC Offset	+0
Daylight Savings Time (DST)	Enabled
Poll Interval	600 seconds

## Spanning Tree Protocols (STP, RSTP, and MSTP)

This section provides the spanning tree, STP RSTP, and MSTP, default settings.

### Spanning Tree Switch Settings

The following table describes the Spanning Tree Protocol default settings for the switch.

Spanning Tree Setting	Default
Spanning Tree Status	Disabled
Active Protocol Version	RSTP

### Spanning Tree Protocol

The following table describes the STP default settings.

STP Setting	Default
Bridge Priority	32768
Bridge Hello Time	2
Bridge Forwarding	15
Bridge Max Age	20
Port Cost	Automatic -Update
Port Priority	128

### Rapid Spanning Tree Protocol

The following table describes the RSTP default settings.

RSTP Setting	Default
Force Version	RSTP
Bridge Priority	32768
Bridge Hello Time	2
Bridge Forwarding	15
Bridge Max Age	20
Edge Port	Yes
Point-to-Point	Auto Detect
Port Cost	Automatic Update
Port Priority	128

## Multiple Spanning Tree Protocol

The following table lists the MSTP default settings.

MSTP Setting	Default
Status	Disabled
Force Version	MSTP
Bridge Hello Time	2
Bridge Forwarding Delay	15
Bridge Max Age	20
Maximum Hops	20
Configuration Name	null
Revision Level	0
CIST Priority	Increment 8 (32768)
Port Priority	Increment 8 (128)
Port Internal Path Cost	Auto Update
Port External Path Cost	Auto Detect
Point-to-Point	Auto Detect
Edge Port	Yes

## Secure Shell Server

---

The following table lists the SSH default settings.

<b>SSH Setting</b>	<b>Default</b>
Status	Disabled
Host Key ID	Not Defined
Server Key ID	Not Defined
Server Key Expiry Time	0 hours
Login Timeout	180 seconds
SSH Port Number	22

The SSH port number is not adjustable.

## Secure Sockets Layer

---

The following table lists the SSL default settings.

<b>SSL Setting</b>	<b>Default</b>
Maximum Number of Sessions	50
Session Cache Timeout	300 seconds

## System Name, Administrator, and Comments Settings

---

The following table describes the IP default settings.

<b>IP Setting</b>	<b>Default</b>
System Name	None
Administrator	None
Comments	None

## Telnet Server

---

The following table lists the Telnet server default settings.

<b>Telnet Server Setting</b>	<b>Default</b>
Telnet Server	Enabled
Telnet Port Number	23
NULL Character	Off

The Telnet port number is not adjustable.

## Virtual Router Redundancy Protocol

---

The following table lists the VRRP default setting.

<b>VRRP Setting</b>	<b>Default</b>
Status	Disabled



## VLANs

---

This section provides the VLAN default settings.

<b>VLAN Setting</b>	<b>Default</b>
Default VLAN Name	Default_VLAN (all ports)
Management VLAN ID	1 (Default_VLAN)
VLAN Mode	User Configured
Uplink Port	None
Ingress Filtering	Disabled

## Web Server

---

The following table lists the web server default settings.

<b>Web Server Configuration Setting</b>	<b>Default</b>
Status	Enabled
Operating Mode	HTTP
HTTP Port Number	80
HTTPS Port Number	443

## Appendix B

# SNMPv3 Configuration Examples

---

This appendix provides two examples of SNMPv3 configuration using the SNMPv3 Table menus and a worksheet to use as an aid when configuring the SNMPv3 protocol. It includes the following sections:

- ❑ “SNMPv3 Manager Configuration” on page 500
- ❑ “SNMPv3 Operator Configuration” on page 501
- ❑ “SNMPv3 Worksheet” on page 502

## SNMPv3 Configuration Examples

---

- ❑ This appendix provides SNMPv3 configuration examples for the following types of users:
- ❑ Manager
- ❑ Operator

In addition an SNMPv3 Configuration Table is provided to record your SNMPv3 configuration.

For more information about the SNMPv3 protocol, see Chapter 21, “SNMPv3” on page 219.

### **SNMPv3 Manager Configuration**

This section provides a sample configuration for a Manager with a User Name of systemadmin24. Each table is listed with its parameters.

#### **Configure SNMPv3 User Table Menu**

```
User Name: systemadmin24
Authentication Protocol: MD5
Privacy Protocol: DES
Storage Type: NonVolatile
```

#### **Configure SNMPv3 View Table Menu**

```
View Name: internet
View Subtree OID: internet (or 1.3.6.1)
Subtree Mask:
View Type: Included
Storage Type: NonVolatile
```

#### **Configure SNMPv3 Access Table**

```
Group Name: Managers
Security Model: SNMPv3
Security Level: P-Authentication and Privacy
Read View Name: internet
write view Name: internet
Notify View Name: internet
Storage Type: NonVolatile
```

**Configure SNMPv3 SecurityToGroup Table**

User Name:systemadmin24  
 Security Model:v3  
 Group Name: Managers  
 Storage Type: NonVolatile

**Configure SNMPv3 Notify Table**

Notify Name: sysadminTrap  
 Notify Tag: sysadminTag  
 Notify Type: Trap  
 Storage Type: NonVolatile

**Configure SNMPv3 Target Address Table**

Target Address Name: host451  
 Target IP Address: 198.35.11.1  
 UDP Port#: 162  
 Timeout: 1500  
 Retries: 3  
 Tag List: sysadminTag  
 Target Parms Name: SNMPmanagerPC  
 Storage Type: NonVolatile

**Configure SNMPv3 Target Parameters Table**

Target Parameters Name:SNMPmanagerPC  
 User Name:systemadmin24  
 Security Model: v3  
 Security Level: P-Authentication and Privacy  
 Storage Type: NonVolatile

**SNMPv3  
Operator  
Configuration**

This section provides a sample configuration for an Operator with a User Name of nikoeng73. Because this user will only send messages to a group and not an SNMP host, you do not need to configure message notification for this user.

**Configure SNMPv3 User Table Menu**

User Name: nikoeng73  
 Authentication Protocol: MD5  
 Privacy Protocol: None  
 Storage Type: NonVolatile

### Configure SNMPv3 View Table Menu

View Name: internet  
 View Subtree OID: 1.3.6.1 (or internet)  
 Subtree Mask:  
 View Type: Included  
 Storage Type: NonVolatile

### Configure SNMPv3 Access Table

Group Name: Operators  
 Security Model: SNMPv3  
 Security Level: Authentication  
 Read View Name: internet  
 Write View Name:  
 Notify View Name:

## SNMPv3 Worksheet

This section supplies a table that you can use a worksheet when configuring SNMPv3. Each SNMPv3 Table is listed with its associated parameters.

SNMPv3 Parameters	
<b>SNMPv3 User Table</b>	
User Name	
Authentication Protocol	
Authentication Password	
Privacy Protocol	
Privacy Password	
Storage Type	
<b>SNMPv3 View Table Menu</b>	
View Name	
View Subtree OID	
Subtree Mask	
View Type	
Storage Type	
<b>SNMPv3 Access Table Menu</b>	
Group Name	

<b>SNMPv3 Parameters (Continued)</b>	
Security Model	
Security Level	
Read View Name	
Write View Name	
Notify View Name	
Storage Type	
<b>SNMPv3 SecurityToGroup Table</b>	
User Name	
Security Model	
Group Name	
Storage Type	
<b>SNMPv3 Notify Table</b>	
Notify Name	
Notify Tag	
Notify Type	
Storage Type	
<b>SNMPv3 Target Address Table</b>	
Target Address Name	
Target IP Address	
UDP Port	
Timeout	
Retries	
Tag List	
Target Params Name	
Storage Type	
<b>SNMPv3 Target Parameters Table</b>	
Target Parameters Name	
User (Security) Name	

<b>SNMPv3 Parameters (Continued)</b>	
Security Model	
Security Level	
Storage Type	



# Features and Standards

---

This appendix lists the features and standards of the AT-9400 Switch. Section include:

- ❑ "10/100/1000Base-T Twisted Pair Ports" on page 506
- ❑ "Denial of Service Defenses" on page 506
- ❑ "Fiber Optic Ports (AT-9408LC/SP Switch)" on page 507
- ❑ "File System" on page 507
- ❑ "Ethernet Protection Switching Ring Snooping" on page 506
- ❑ "DHCP and BOOTP Clients" on page 507
- ❑ "Internet Protocol Multicasting" on page 507
- ❑ "Internet Protocol Version 4 Routing" on page 507
- ❑ "MAC Address Table" on page 508
- ❑ "Management Access and Security" on page 508
- ❑ "Management Access Methods" on page 509
- ❑ "Management Interfaces" on page 509
- ❑ "Management MIBs" on page 509
- ❑ "Port Security" on page 510
- ❑ "Port Trunking and Mirroring" on page 510
- ❑ "Spanning Tree Protocols" on page 510
- ❑ "System Monitoring" on page 510
- ❑ "Traffic Control" on page 511
- ❑ "Virtual LANs" on page 511
- ❑ "Virtual Router Redundancy Protocol" on page 512

---

### **Note**

The AT-9400 Layer 2+ Switches do not support all the features. For a list of supported features, refer to "Layer 2+ and Basic Layer 3 Switches" on page 30.

---

## 10/100/1000Base-T Twisted Pair Ports

---

IEEE 802.1d	Bridging
IEEE 802.3	10Base-T
IEEE 802.3u	100Base-TX
IEEE 802.3ab	1000Base-T
IEEE 802.3u	Auto-Negotiation
IEEE 802.3x	10/100 Mbps Flow Control / Backpressure
IEEE 802.3z	1000 Mbps Flow Control
—	Auto-MDI/MDIX
—	Head of Line Blocking
—	Eight Egress Queues Per Port
—	Bad cable detection

## Denial of Service Defenses

---

Smurf  
SYN Flood  
Teardrop  
Land  
IP Option  
Ping of Death

## Ethernet Protection Switching Ring Snooping

---

— Ethernet Protection Switching Ring Snooping

## Fiber Optic Ports (AT-9408LC/SP Switch)

---

IEEE 802.1d	Bridging
IEEE 802.3z	1000Base-SX
—	Head of Line Blocking
—	Eight Egress Queues Per Port

## File System

---

—	8 megabyte storage capacity
---	-----------------------------

## DHCP and BOOTP Clients

---

RFC 2131	DHCP client
RFC 951, 1542	BOOTP client

## Internet Protocol Multicasting

---

RFC 1112	IGMP Snooping (Ver. 1.0)
RFC 2236	IGMP Snooping (Ver. 2.0)
RFC 3376	IGMP Snooping (Ver. 3.0)
RFC 2710	MLD Snooping (Ver. 1.0)
RFC 3810	MLD Snooping (Ver. 2.0)
RFC 3768	RRP Snooping

## Internet Protocol Version 4 Routing

---

—	Routing Interfaces
—	Static Routes
RFC 1058	RIP version 1
RFC 1723	RIP version 2

RFC 826	Address Resolution Protocol
—	Equal Cost Multi-path
—	Split Horizon and Split Horizon with Poison Reverse
—	Autosummarization of Routes
RFC 1542	BOOTP Relay

## MAC Address Table

---

—	Storage capacity of 16K entries
---	---------------------------------

## Management Access and Security

---

RFC 1157	SNMPv1
RFC 1901	SNMPv2
RFC 3411	SNMPv3
RFC 1492	TACACS+ Client
RFC 2865	RADIUS Client
RFC 2068	HTTP
RFC 2616	HTTPS
RFC 1866	HTML
RFC 854	Telnet Server
—	Secure Sockets Layer (SSL)
RFC 4325 (X.509)	Public Key Infrastructure (PKI)
—	Encryption Keys
—	Secure Shell (SSH) (Vers. 1.3, 1.5, 2.0)
—	Management Access Control List
RFC 1350	TFTP client
RFC 2030	SNTP client

## Management Access Methods

---

Enhanced Stacking™

Out-of-band management (serial port)

In-band management (over the network) using Telnet, SSH, web browser, and SNMP

## Management Interfaces

---

Menus

Command Line

Web Browser

SNMP v1, v2, & v3

## Management MIBs

---

RFC 1213	MIB-II
RFC 1215	TRAP MIB
RFC 1493	Bridge MIB
RFC 2863	Interface Group MIB
RFC 2933	IGMP
RFC 1643	Ethernet-like MIB
RFC 2674	IEEE 802.1Q MIB
RFC 1757	RMON 4 groups
—	Allied Telesis Private MIBs

## Port Security

---

IEEE 802.1x	Port-based Network Access Control: Supports multiple supplicants per port and the following authentication methods:  EAP-MD5  EAP-TLS  EAP-TTLS  PEAP
RFC 2865	RADIUS Client
RFC 2866	RADIUS Accounting
—	MAC Address-based security

## Port Trunking and Mirroring

---

IEEE 802.3ad	Link Aggregation Control Protocol (LACP)
—	Static Port Trunking
—	Port Mirroring

## Spanning Tree Protocols

---

IEEE 802.1D	Spanning Tree Protocol
IEEE 802.1w	Rapid Spanning Tree Protocol
IEEE 802.1s	Multiple Spanning Tree Protocol

## System Monitoring

---

RFC 3195	Syslog Client
—	Temporary Event Log (4,000 events maximum)
—	Permanent Event Log (2,000 events maximum)
—	Port and System Statistics

RFC 1757

RMON Groups 1, 2, 3, and 9

## Traffic Control

---

RFC 2386

Quality of Service featuring:

- Layer 2, 3, and 4 criteria
- Flow Groups, Traffic Classes, and Policies
- DSCP Replacement
- 802.1q Priority Replacement
- Type of Service Replacement
- Type of Service to 802.1q Priority Replacement
- 802.1q Priority to Type of Service Replacement
- Maximum Bandwidth Control
- Burst Size Control
- Support on Ingress and Egress Ports

IEEE 802.1p

Class of Service with Strict and Weighted Round Robin Scheduling

- Port Access Control Lists
- Ingress and Egress Control of Broadcast, Multicast, and Unknown Unicast Traffic
- Ingress Packet Rate Limiting

## Virtual LANs

---

IEEE 802.1Q

Tagged VLANs

- Port-based VLANs
- Compliant and Non-compliant 802.1Q Multiple VLAN Modes
- Protected Ports VLANs

—	MAC Address-based VLANs (Not supported on the AT-9408LC/SP, AT-9424T/GB, and AT-9424T/SP switches.)
IEEE 802.3ac	VLAN Tag Frame Extension
IEEE 802.1P	GARP VLAN Registration Protocol

## **Virtual Router Redundancy Protocol**

---

RFC 3768	Virtual Router Redundancy Protocol
----------	------------------------------------



## Appendix D

# MIB Objects

---

This appendix lists the SNMP MIB objects in the private Allied Telesis MIBs that apply to the AT-S63 Management Software and the AT-9400 Switch. Sections in the appendix include:

- ❑ "Access Control Lists" on page 514
- ❑ "Class of Service" on page 515
- ❑ "Date, Time, and SNTP Client" on page 516
- ❑ "Denial of Service Defenses" on page 517
- ❑ "Enhanced Stacking" on page 518
- ❑ "GVRP" on page 519
- ❑ "MAC Address Table" on page 521
- ❑ "Management Access Control List" on page 522
- ❑ "Miscellaneous" on page 523
- ❑ "Port Mirroring" on page 524
- ❑ "Quality of Service" on page 525
- ❑ "Port Configuration and Status" on page 527
- ❑ "Spanning Tree" on page 528
- ❑ "Static Port Trunk" on page 529
- ❑ "VLANs" on page 530

The Allied Telesis MIB files for the AT-9400 Switch are:

- ❑ atiStackSwitch.mib (version 2.31)
- ❑ atiStackInfo.mib (version 1.3)

The MIB files are available from the Allied Telesis web site. Objects in the private MIBs have the prefix "1.3.6.1.4.1.207."

---

### **Note**

The AT-9400 Switch supports only a limited number of management functions from SNMP.

---

## Access Control Lists

---

Table 31. Access Control Lists (AtiStackSwitch MIB)

<b>Object Name</b>	<b>OID</b>
atiStkSwACLConfigTable	1.3.6.1.4.1.207.8.17.9.1
atiStkSwACLConfigEntry	1.3.6.1.4.1.207.8.17.9.1.1
atiStkSwACLModuleId	1.3.6.1.4.1.207.8.17.9.1.1.1
atiStkSwACLIId	1.3.6.1.4.1.207.8.17.9.1.1.2
atiStkSwACLDescription	1.3.6.1.4.1.207.8.17.9.1.1.3
atiStkSwACLAction	1.3.6.1.4.1.207.8.17.9.1.1.4
atiStkSwACLClassifierList	1.3.6.1.4.1.207.8.17.9.1.1.5
atiStkSwACLPortList	1.3.6.1.4.1.207.8.17.9.1.1.6
atiStkSwACLRowStatus	1.3.6.1.4.1.207.8.17.9.1.1.7

## Class of Service

---

Table 32. CoS Scheduling (AtiStackSwitch MIB)

Object Name	OID
atiSwQoSGroup	1.3.6.1.4.1.207.8.17.7
atiStkSwQoSGroupNumberOfQueues	1.3.6.1.4.1.207.8.17.7.1
atiStkSwQoSGroupSchedulingMode	1.3.6.1.4.1.207.8.17.7.2

Table 33. CoS Priority to Egress Queue Mappings (AtiStackSwitch MIB)

Object Name	OID
atiStkSwQoSGroupCoSToQueueTable	1.3.6.1.4.1.207.8.17.7.3
atiStkSwQoSGroupCoSToQueueEntry	1.3.6.1.4.1.207.8.17.7.3.1
atiStkSwQoSGroupCoSPriority	1.3.6.1.4.1.207.8.17.7.3.1.1
atiStkSwQoSGroupCoSQueue	1.3.6.1.4.1.207.8.17.7.3.1.2

Table 34. CoS Packet Weights of Egress Queues (AtiStackSwitch MIB)

Object Name	OID
atiStkSwQoSGroupQueueToWeightTable	1.3.6.1.4.1.207.8.17.7.4
AtiStkSwQoSGroupQueueToWeightEntry	1.3.6.1.4.1.207.8.17.7.4.1
atiStkSwQoSGroupQueue	1.3.6.1.4.1.207.8.17.7.4.1.1
atiStkSwQoSGroupQueueWeight	1.3.6.1.4.1.207.8.17.7.4.1.2

Table 35. CoS Port Settings (AtiStackSwitch MIB)

Object Name	OID
atiStkSwQoSGroupPortCoSPriorityTable	1.3.6.1.4.1.207.8.17.7.8
atiStkSwQoSGroupPortCoSPriorityEntry	1.3.6.1.4.1.207.8.17.7.8.1
atiStkSwQoSGroupPortCoSPriorityModuleId	1.3.6.1.4.1.207.8.17.7.8.1.1
atiStkSwQoSGroupPortCoSPriorityPortId	1.3.6.1.4.1.207.8.17.7.8.1.2
atiStkSwQoSGroupPortCoSPriorityPriority	1.3.6.1.4.1.207.8.17.7.8.1.3
atiStkSwQoSGroupPortCoSPriorityOverridePriority	1.3.6.1.4.1.207.8.17.7.8.1.4

## Date, Time, and SNTP Client

---

Table 36. Date, Time, and SNTP Client (AtiStackSwitch MIB)

<b>Object Name</b>	<b>OID</b>
atiStkSysSystemTimeConfig	1.3.6.1.4.1.207.8.17.1.5
atiStkSwSysCurrentTime	1.3.6.1.4.1.207.8.17.1.5.1
atiStkSwSysCurrentDate	1.3.6.1.4.1.207.8.17.1.5.2
atiStkSwSysSNTPStatus	1.3.6.1.4.1.207.8.17.1.5.3
atiStkSwSysSNTPServerIPAddress	1.3.6.1.4.1.207.8.17.1.5.4
atiStkSwSysSNTPUTCOffset	1.3.6.1.4.1.207.8.17.1.5.5
atiStkSwSysSNTPDSTStatus	1.3.6.1.4.1.207.8.17.1.5.6
atiStkSwSysSNTPPollingInterval	1.3.6.1.4.1.207.8.17.1.5.7
atiStkSwSysSNTPLastDelta	1.3.6.1.4.1.207.8.17.1.5.8

## Denial of Service Defenses

---

Table 37. LAN Address and Subnet Mask (AtiStackSwitch MIB)

Object Name	OID
atiStkDOSConfig	1.3.6.1.4.1.207.8.17.2.6
atiStkDOSConfigLANIpAddress	1.3.6.1.4.1.207.8.17.2.6.1
atiStkDOSConfigLANSubnetMask	1.3.6.1.4.1.207.8.17.2.6.2

Table 38. Denial of Service Defenses (AtiStackSwitch MIB)

Object Name	OID
atiStkPortDOSAttackConfigTable	1.3.6.1.4.1.207.8.17.2.6.3
atiStkPortDOSAttackConfigEntry	1.3.6.1.4.1.207.8.17.2.6.3.1
atiStkPortDOSAttackType	1.3.6.1.4.1.207.8.17.2.6.3.1.1
atiStkPortDOSAttackActionStatus	1.3.6.1.4.1.207.8.17.2.6.3.1.2
atiStkPortDOSAttackMirrorPort	1.3.6.1.4.1.207.8.17.2.6.3.1.3
atiStkPortDOSAttackMirrorPortStatus	1.3.6.1.4.1.207.8.17.2.6.3.1.4

## Enhanced Stacking

---

Table 39. Switch Mode and Discovery (AtiStackInfo MIB)

Object Name	OID
atiswitchEnhancedStackingInfo	1.3.6.1.4.1.207.8.16.1
atiswitchEnhStackMode	1.3.6.1.4.1.207.8.16.1.1
atiswitchEnhStackDiscover	1.3.6.1.4.1.207.8.16.1.2
atiswitchEnhStackRemoteNumber	1.3.6.1.4.1.207.8.16.1.3

Table 40. Switches of an Enhanced Stack (AtiStackInfo MIB)

Object Name	OID
atiswitchEnhStackTable	1.3.6.1.4.1.207.8.16.1.4
atiswitchEnhStackEntry	1.3.6.1.4.1.207.8.16.1.4.1
atiswitchEnhStackSwId	1.3.6.1.4.1.207.8.16.1.4.1.1
atiswitchEnhStackSwMacAddr	1.3.6.1.4.1.207.8.16.1.4.1.2
atiswitchEnhStackSwName	1.3.6.1.4.1.207.8.16.1.4.1.3
atiswitchEnhStackSwMode	1.3.6.1.4.1.207.8.16.1.4.1.4
atiswitchEnhStackSwSoftwareVersion	1.3.6.1.4.1.207.8.16.1.4.1.5
atiswitchEnhStackSwModel	1.3.6.1.4.1.207.8.16.1.4.1.6
atiswitchEnhStackConnect	1.3.6.1.4.1.207.8.16.1.4.1.7

## GVRP

Table 41. GVFP Switch Configuration (AtiStackSwitch MIB)

Object Name	OID
atiStkSwGVRPConfig	1.3.6.1.4.1.207.8.17.3.6
atiStkSwGVRPStatus	1.3.6.1.4.1.207.8.17.3.6.1
atiStkSwGVRPGIPStatus	1.3.6.1.4.1.207.8.17.3.6.2
atiStkSwGVRPJoinTimer	1.3.6.1.4.1.207.8.17.3.6.3
atiStkSwGVRPLeaveTimer	1.3.6.1.4.1.207.8.17.3.6.4
atiStkSwGVRPLeaveAllTimer	1.3.6.1.4.1.207.8.17.3.6.5

Table 42. GVRP Port Configuration (AtiStackSwitch MIB)

Object Name	OID
atiStkSwGVRPPortConfigTable	1.3.6.1.4.1.207.8.17.3.7
atiStkSwGVRPPortConfigEntry	1.3.6.1.4.1.207.8.17.3.7.1
atiStkSwGVRPPortConfigModuleId	1.3.6.1.4.1.207.8.17.3.7.1.1
atiStkSwGVRPPortConfigPortId	1.3.6.1.4.1.207.8.17.3.7.1.2
atiStkSwGVRPPortConfigStatus	1.3.6.1.4.1.207.8.17.3.7.1.3

Table 43. GVRP Counters (AtiStackSwitch MIB)

Object Name	OID
atiStkSwGVRPCountersTable	1.3.6.1.4.1.207.8.17.3.8
atiStkSwGVRPCountersEntry	1.3.6.1.4.1.207.8.17.3.8.1
atiStkSwGVRPCountersModuleId	1.3.6.1.4.1.207.8.17.3.8.1.1
atiStkSwGVRPCountersGARPRxPkt	1.3.6.1.4.1.207.8.17.3.8.1.2
atiStkSwGVRPCountersInvalidGARPRxPkt	1.3.6.1.4.1.207.8.17.3.8.1.3
atiStkSwGVRPCountersGARPTxPkt	1.3.6.1.4.1.207.8.17.3.8.1.4
atiStkSwGVRPCountersGARPTxDisabled	1.3.6.1.4.1.207.8.17.3.8.1.5
atiStkSwGVRPCountersPortNotSending	1.3.6.1.4.1.207.8.17.3.8.1.6
atiStkSwGVRPCountersGARPDisabled	1.3.6.1.4.1.207.8.17.3.8.1.7

Table 43. GVRP Counters (AtiStackSwitch MIB)

<b>Object Name</b>	<b>OID</b>
atiStkSwGVRPCountersPortNotListening	1.3.6.1.4.1.207.8.17.3.8.1.8
atiStkSwGVRPCountersInvalidPort	1.3.6.1.4.1.207.8.17.3.8.1.9
atiStkSwGVRPCountersInvalidProtocol	1.3.6.1.4.1.207.8.17.3.8.1.10
atiStkSwGVRPCountersInvalidFormat	1.3.6.1.4.1.207.8.17.3.8.1.11
atiStkSwGVRPCountersDatabaseFull	1.3.6.1.4.1.207.8.17.3.8.1.12
atiStkSwGVRPCountersRxMsgLeaveAll	1.3.6.1.4.1.207.8.17.3.8.1.13
atiStkSwGVRPCountersRxMsgJoinEmpty	1.3.6.1.4.1.207.8.17.3.8.1.14
atiStkSwGVRPCountersRxMsgJoinIn	1.3.6.1.4.1.207.8.17.3.8.1.15
atiStkSwGVRPCountersRxMsgLeaveEmpty	1.3.6.1.4.1.207.8.17.3.8.1.16
atiStkSwGVRPCountersRxMsgLeaveIn	1.3.6.1.4.1.207.8.17.3.8.1.17
atiStkSwGVRPCountersRxMsgEmpty	1.3.6.1.4.1.207.8.17.3.8.1.18
atiStkSwGVRPCountersRxMsgBadMsg	1.3.6.1.4.1.207.8.17.3.8.1.19
atiStkSwGVRPCountersRxMsgBadAttribute	1.3.6.1.4.1.207.8.17.3.8.1.20
atiStkSwGVRPCountersTxMsgLeaveAll	1.3.6.1.4.1.207.8.17.3.8.1.21
atiStkSwGVRPCountersTxMsgJoinEmpty	1.3.6.1.4.1.207.8.17.3.8.1.22
atiStkSwGVRPCountersTxMsgJoinIn	1.3.6.1.4.1.207.8.17.3.8.1.23
atiStkSwGVRPCountersTxMsgLeaveEmpty	1.3.6.1.4.1.207.8.17.3.8.1.24
atiStkSwGVRPCountersTxMsgLeaveIn	1.3.6.1.4.1.207.8.17.3.8.1.25
atiStkSwGVRPCountersTxMsgEmpty	1.3.6.1.4.1.207.8.17.3.8.1.26



## MAC Address Table

---

Table 44. MAC Address Table (AtiStackSwitch MIB)

Object Name	OID
atiStkSwMacAddr2VlanTable	1.3.6.1.4.1.207.8.17.3.3
atiStkSwMacAddr2VlanEntry	1.3.6.1.4.1.207.8.17.3.3.1
atiStkSwMacAddress	1.3.6.1.4.1.207.8.17.3.3.1.1
atiStkSwMacAddrVlanId	1.3.6.1.4.1.207.8.17.3.3.1.2
atiStkSwMacAddrVlanName	1.3.6.1.4.1.207.8.17.3.3.1.3
atiStkSwMacAddrModuleId	1.3.6.1.4.1.207.8.17.3.3.1.4
atiStkSwMacAddrPortId	1.3.6.1.4.1.207.8.17.3.3.1.5
atiStkSwMacAddrPortList	1.3.6.1.4.1.207.8.17.3.3.1.6

Table 45. Static MAC Address Table (AtiStackSwitch MIB)

Object Name	OID
atiStkSwMacAddrGroup	1.3.6.1.4.1.207.8.17.4
atiStkSwStaticMacAddrEntry	1.3.6.1.4.1.207.8.17.4.1.1
atiStkSwStaticMacAddress	1.3.6.1.4.1.207.8.17.4.1.1.1
atiStkSwStaticMacAddrVlanId	1.3.6.1.4.1.207.8.17.4.1.1.2
atiStkSwStaticMacAddrModuleId	1.3.6.1.4.1.207.8.17.4.1.1.3
atiStkSwStaticMacAddrPortId	1.3.6.1.4.1.207.8.17.4.1.1.4
atiStkSwStaticMacAddrPortList	1.3.6.1.4.1.207.8.17.4.1.1.5
atiStkSwStaticMacAddrEntryStatus	1.3.6.1.4.1.207.8.17.4.1.1.6

## Management Access Control List

---

Table 46. Management Access Control List Status (AtiStackSwitch MIB)

Object Name	OID
atiStkSwSysMgmtACLGroup	1.3.6.1.4.1.207.8.17.1.7
atiStkSwSysMgmtACLStatus	1.3.6.1.4.1.207.8.17.1.7.1

Table 47. Management Access Control List Entries (AtiStackSwitch MIB)

Object Name	OID
atiStkSwSysMgmtACLConfigTable	1.3.6.1.4.1.207.8.17.1.7.2
atiStkSwSysMgmtACLConfigEntry	1.3.6.1.4.1.207.8.17.1.7.2.1
atiStkSwSysMgmtACLConfigModuleId	1.3.6.1.4.1.207.8.17.1.7.2.1.1
atiStkSwSysMgmtACLConfigId	1.3.6.1.4.1.207.8.17.1.7.2.1.2
atiStkSwSysMgmtACLConfigIpAddr	1.3.6.1.4.1.207.8.17.1.7.2.1.3
atiStkSwSysMgmtACLConfigMask	1.3.6.1.4.1.207.8.17.1.7.2.1.4
atiStkSwSysMgmtACLConfigApplication	1.3.6.1.4.1.207.8.17.1.7.2.1.5
atiStkSwSysMgmtACLConfigRowStatus	1.3.6.1.4.1.207.8.17.1.7.2.1.6

## Miscellaneous

---

Table 48. System Reset (AtiStackSwitch MIB)

Object Name	OID
atiStkSwSysGroup	1.3.6.1.4.1.207.8.17.1
atiStkSwSysConfig	1.3.6.1.4.1.207.8.17.1.1
atiStkSwSysReset	1.3.6.1.4.1.207.8.17.1.1.1

Table 49. Local Interface (AtiStackSwitch MIB)

Object Name	OID
atiStkSwSysGroup	1.3.6.1.4.1.207.8.17.1
atiStkSwSysConfig	1.3.6.1.4.1.207.8.17.1.1
atiStkSwSysIpAddress	1.3.6.1.4.1.207.8.17.1.1.2
atiStkSwSysSubnetMask	1.3.6.1.4.1.207.8.17.1.1.3
atiStkSwSysGateway	1.3.6.1.4.1.207.8.17.1.1.4
atiStkSwSysIpAddressStatus	1.3.6.1.4.1.207.8.17.1.1.5

Table 50. Saving the Configuration and Returning to Default Settings (AtiStackSwitch MIB)

Object Name	OID
atiStkSwSysGroup	1.3.6.1.4.1.207.8.17.1
atiStkSwSysConfig	1.3.6.1.4.1.207.8.17.1.1
atiStkSwSysAction	1.3.6.1.4.1.207.8.17.1.1.11

## Port Mirroring

---

Table 51. Port Mirroring (AtiStackSwitch MIB)

<b>Object Name</b>	<b>OID</b>
atiStkSwPortMirroringConfig	1.3.6.1.4.1.207.8.17.2.2
atiStkSwPortMirroringState	1.3.6.1.4.1.207.8.17.2.2.1
atiStkSwPortMirroringDestinationModuleId	1.3.6.1.4.1.207.8.17.2.2.4
atiStkSwPortMirroringDestinationPortId	1.3.6.1.4.1.207.8.17.2.2.5
atiStkSwPortMirroringSourceRxList	1.3.6.1.4.1.207.8.17.2.2.6
atiStkSwPortMirroringSourceTxList	1.3.6.1.4.1.207.8.17.2.2.7

## Quality of Service

---

Table 52. Flow Groups (AtiStackSwitch MIB)

Object Name	OID
atiStkSwQosFlowGrpTable	1.3.6.1.4.1.207.8.17.7.5
atiStkSwQosFlowGrpEntry	1.3.6.1.4.1.207.8.17.7.5.1
atiStkSwQosFlowGrpModuleId	1.3.6.1.4.1.207.8.17.7.5.1.1
atiStkSwQosFlowGrpId	1.3.6.1.4.1.207.8.17.7.5.1.2
atiStkSwQosFlowGrpDescription	1.3.6.1.4.1.207.8.17.7.5.1.3
atiStkSwQosFlowGrpDSCPValue	1.3.6.1.4.1.207.8.17.7.5.1.4
atiStkSwQosFlowGrpPriority	1.3.6.1.4.1.207.8.17.7.5.1.5
atiStkSwQosFlowGrpRemarkPriority	1.3.6.1.4.1.207.8.17.7.5.1.6
atiStkSwQosFlowGrpTos	1.3.6.1.4.1.207.8.17.7.5.1.7
atiStkSwQosFlowGrpTosToPriority	1.3.6.1.4.1.207.8.17.7.5.1.8
atiStkSwQosFlowGrpPriorityToTos	1.3.6.1.4.1.207.8.17.7.5.1.9
atiStkSwQosFlowGrpClassifierList	1.3.6.1.4.1.207.8.17.7.5.1.10
atiStkSwQosFlowGrpRowStatus	1.3.6.1.4.1.207.8.17.7.5.1.11

Table 53. Traffic Classes (AtiStackSwitch MIB)

Object Name	OID
atiStkSwQosTrafficClassTable	1.3.6.1.4.1.207.8.17.7.6
atiStkSwQosTrafficClassEntry	1.3.6.1.4.1.207.8.17.7.6.1
atiStkSwQosTrafficClassModuleId	1.3.6.1.4.1.207.8.17.7.6.1.1
atiStkSwQosTrafficClassId	1.3.6.1.4.1.207.8.17.7.6.1.2
atiStkSwQosTrafficClassDescription	1.3.6.1.4.1.207.8.17.7.6.1.3
atiStkSwQosTrafficClassExceedAction	1.3.6.1.4.1.207.8.17.7.6.1.4
atiStkSwQosTrafficClassExceedRemarkValue	1.3.6.1.4.1.207.8.17.7.6.1.5
atiStkSwQosTrafficClassDSCPValue	1.3.6.1.4.1.207.8.17.7.6.1.6
atiStkSwQosTrafficClassMaxBandwidth	1.3.6.1.4.1.207.8.17.7.6.1.7
atiStkSwQosTrafficClassBurstSize	1.3.6.1.4.1.207.8.17.7.6.1.8

Table 53. Traffic Classes (AtiStackSwitch MIB)

Object Name	OID
atiStkSwQosTrafficClassClassPriority	1.3.6.1.4.1.207.8.17.7.6.1.9
atiStkSwQosTrafficClassRemarkPriority	1.3.6.1.4.1.207.8.17.7.6.1.10
atiStkSwQosTrafficClassToS	1.3.6.1.4.1.207.8.17.7.6.1.11
atiStkSwQosTrafficClassMoveToSToPriority	1.3.6.1.4.1.207.8.17.7.6.1.12
atiStkSwQosTrafficClassMovePriorityToToS	1.3.6.1.4.1.207.8.17.7.6.1.13
atiStkSwQosTrafficClassFlowGroupList	1.3.6.1.4.1.207.8.17.7.6.1.14
atiStkSwQosTrafficClassStatus	1.3.6.1.4.1.207.8.17.7.6.1.15

Table 54. Policies (AtiStackSwitch MIB)

Object Name	OID
atiStkSwQosPolicyTable	1.3.6.1.4.1.207.8.17.7.7
atiStkSwQosPolicyEntry	1.3.6.1.4.1.207.8.17.7.7.1
atiStkSwQosPolicyModuleId	1.3.6.1.4.1.207.8.17.7.7.1.1
atiStkSwQosPolicyId	1.3.6.1.4.1.207.8.17.7.7.1.2
atiStkSwQosPolicyDescription	1.3.6.1.4.1.207.8.17.7.7.1.3
atiStkSwQosPolicyRemarkDSCP	1.3.6.1.4.1.207.8.17.7.7.1.4
atiStkSwQosPolicyDSCPValue	1.3.6.1.4.1.207.8.17.7.7.1.5
atiStkSwQosPolicyDSCPValue	1.3.6.1.4.1.207.8.17.7.7.1.6
atiStkSwQosPolicyMoveToSToPriority	1.3.6.1.4.1.207.8.17.7.7.1.7
atiStkSwQosPolicyMovePriorityToToS	1.3.6.1.4.1.207.8.17.7.7.1.8
atiStkSwQosPolicySendToMirrorPort	1.3.6.1.4.1.207.8.17.7.7.1.9
atiStkSwQosPolicyClassList	1.3.6.1.4.1.207.8.17.7.7.1.10
atiStkSwQosPolicyRedirectPort	1.3.6.1.4.1.207.8.17.7.7.1.11
atiStkSwQosPolicyIngressPortList	1.3.6.1.4.1.207.8.17.7.7.1.12
atiStkSwQosPolicyEgressPortList	1.3.6.1.4.1.207.8.17.7.7.1.13
atiStkSwQosPolicyRowStatus	1.3.6.1.4.1.207.8.17.7.7.1.14

## Port Configuration and Status

---

Table 55. Port Configuration and Status (AtiStackSwitch MIB)

<b>Object Name</b>	<b>OID</b>
atiStkSwPortConfigTable	1.3.6.1.4.1.207.8.17.2.1
atiStkPortConfigEntry	1.3.6.1.4.1.207.8.17.2.1.1
atiStkSwModuleId	1.3.6.1.4.1.207.8.17.2.1.1.1
atiStkSwPortId	1.3.6.1.4.1.207.8.17.2.1.1.2
atiStkSwPortName	1.3.6.1.4.1.207.8.17.2.1.1.3
atiStkSwPortState	1.3.6.1.4.1.207.8.17.2.1.1.4
atiStkSwPortLinkState	1.3.6.1.4.1.207.8.17.2.1.1.5
atiStkSwPortNegotiation	1.3.6.1.4.1.207.8.17.2.1.1.6
atiStkSwPortSpeed	1.3.6.1.4.1.207.8.17.2.1.1.7
atiStkSwPortDuplexStatus	1.3.6.1.4.1.207.8.17.2.1.1.8
atiStkSwPortFlowControl	1.3.6.1.4.1.207.8.17.2.1.1.9
atiStkSwPortBackPressure	1.3.6.1.4.1.207.8.17.2.1.1.10
atiStkSwPortPriority	1.3.6.1.4.1.207.8.17.2.1.1.11
atiStkSwPortBroadcastProcessing	1.3.6.1.4.1.207.8.17.2.1.1.12
atiStkSwPortMDIO	1.3.6.1.4.1.207.8.17.2.1.1.13
atiStkSwPortHOLLimit	1.3.6.1.4.1.207.8.17.2.1.1.14
atiStkSwPortBackPressureLimit	1.3.6.1.4.1.207.8.17.2.1.1.15
atiStkSwPortSTPState	1.3.6.1.4.1.207.8.17.2.1.1.16

## Spanning Tree

---

Table 56. Spanning Tree (AtiStackSwitch MIB)

<b>Object Name</b>	<b>OID</b>
atiStkSwSysConfig	1.3.6.1.4.1.207.8.17.1.1
atiStkSwSysSpanningTreeStatus	1.3.6.1.4.1.207.8.17.1.1.9
atiStkSwSysSpanningTreeVersion	1.3.6.1.4.1.207.8.17.1.1.10



## Static Port Trunk

---

Table 57. Static Port Trunks (AtiStackSwitch MIB)

<b>Object Name</b>	<b>OID</b>
atiStkSwStaticTrunkTable	1.3.6.1.4.1.207.8.17.8.1
atiStkSwStaticTrunkEntry	1.3.6.1.4.1.207.8.17.8.1.1
atiStkSwStaticTrunkModuleId	1.3.6.1.4.1.207.8.17.8.1.1.1
atiStkSwStaticTrunkIndex	1.3.6.1.4.1.207.8.17.8.1.1.2
atiStkSwStaticTrunkId	1.3.6.1.4.1.207.8.17.8.1.1.3
atiStkSwStaticTrunkName	1.3.6.1.4.1.207.8.17.8.1.1.4
atiStkSwStaticTrunkMethod	1.3.6.1.4.1.207.8.17.8.1.1.5
atiStkSwStaticTrunkPortList	1.3.6.1.4.1.207.8.17.8.1.1.6
atiStkSwStaticTrunkStatus	1.3.6.1.4.1.207.8.17.8.1.1.7
atiStkSwStaticTrunkRowStatus	1.3.6.1.4.1.207.8.17.8.1.1.8

## VLANs

---

The objects in Table 58 display the specifications of the Default\_VLAN.

Table 58. VLAN Table (AtiStackSwitch MIB)

Object Name	OID
atiStkSwVlanConfigTable	1.3.6.1.4.1.207.8.17.3.1
atiStkSwVlanConfigEntry	1.3.6.1.4.1.207.8.17.3.1.1
atiStkSwVlanId	1.3.6.1.4.1.207.8.17.3.1.1.1
atiStkSwVlanName	1.3.6.1.4.1.207.8.17.3.1.1.2
atiStkSwVlanTaggedPortListModule1	1.3.6.1.4.1.207.8.17.3.1.1.3
atiStkSwVlanUntaggedPortListModule1	1.3.6.1.4.1.207.8.17.3.1.1.4
atiStkSwVlanConfigEntryStatus	1.3.6.1.4.1.207.8.17.3.1.1.19
atiStkSwVlanActualUntaggedPortListModule1	1.3.6.1.4.1.207.8.17.3.1.1.20

The objects in Table 59 display the names and VIDs of all the VLANs on a switch, but not the VLAN ports.

Table 59. VLAN Table (AtiStackSwitch MIB)

Object Name	OID
atiStkSwPort2VlanTable	1.3.6.1.4.1.207.8.17.3.2
atiStkSwPort2VlanEntry	1.3.6.1.4.1.207.8.17.3.2.1
atiStkSwPortVlanId	1.3.6.1.4.1.207.8.17.3.2.1.1
atiStkSwPortVlanName	1.3.6.1.4.1.207.8.17.3.2.1.2

Table 60. VLAN Mode and Uplink Port (AtiStackSwitch MIB)

Object Name	OID
atiStkSwVlanGroup	1.3.6.1.4.1.207.8.17.3
atiStkSwVlanMode	1.3.6.1.4.1.207.8.17.3.4
atiStkSwVlanUplinkVlanPort	1.3.6.1.4.1.207.8.17.3.5

Table 61. PVID Table (AtiStackSwitch MIB)

<b>Object Name</b>	<b>OID</b>
atiStkSwPort2VlanTable	1.3.6.1.4.1.207.8.17.3.2
atiStkSwPort2VlanEntry	1.3.6.1.4.1.207.8.17.3.2.1
atiStkSwPortVlanId	1.3.6.1.4.1.207.8.17.3.2.1.1
atiStkSwPortVlanName	1.3.6.1.4.1.207.8.17.3.2.1.2



# Index

---

## Numerics

- 802.1p priority level in classifiers 129
- 802.1Q-compliant VLAN mode 298
- 802.1x Port-based Network Access Control
  - authentication process 383
  - authenticator port role 381
  - default settings 470
  - described 381
  - guidelines 399
  - port roles 384
  - supplicant port role 381
  - supported platforms 380

## A

- access control entries (ACE)
  - described 457
  - examples 460
  - parts of 458
- access control lists
  - actions 137
  - classifiers 127
  - deny ACL 137
  - described 137
  - examples 141
  - guidelines 140
  - permit ACL 137
- ACE. *See* access control entry (ACE)
- ACL. *See* access control lists
- Address Resolution Protocol (ARP) 339
- Address Resolution Protocol (ARP) table
  - timeout value, default setting 465
- adminkey parameter in aggregate trunks 107
- aggregate trunk 105
- aggregator 105
- aging time, MAC address table 95, 479
- associations 255
- AT-S63 Management Software
  - default settings 463
  - described 36
- AT-StackXG Stacking Module 63
- authentication protocols 449
  - See also* RADIUS, TACACS+
- authentication server 382
- authenticator port role 381, 384
- Auto-Detect feature 239
- automatic port security mode 375
- autosummarization of routes 333

## B

- backup switches in Virtual Router Redundancy Protocol (VRRP) 365
- boot configuration files
  - default names 466
- BOOTP relay agent
  - default settings 467
  - described 357
  - guidelines 359
  - supported platforms 356
- bridge identifier 238
- bridge priority 238
- bridge protocol data units (BPDU) 242
- broadcast frame control
  - configuring, 189

## C

- CA. *See* certification authority (CA)
- certificate enrollment request 424
- certificate revocation list (CRL), described 434
- certificates
  - described 423, 431, 432
  - guidelines 428
  - PKI, validating 434
  - X.509 432
- certification authority (CA)
  - described 433
  - root 434
- CIST. *See* Common and Internal Spanning Tree
- Class of Service (CoS)
  - default settings 468
  - described 149
  - priority level and egress queue mappings 149
  - scheduling 152
  - supported platforms 148
- classifiers
  - 802.1p priority level 129
  - components of 129
  - described 127
  - destination MAC addresses 129
  - Ethernet 802.2 129
  - Ethernet II frame types 129
  - guidelines 134
  - IP destination addresses 132
  - IP DSCP 131
  - IP protocol 132
  - IP source addresses 132
  - IP Type of Service 131
  - protocols 130

- source MAC addresses 129
- TCP flags 133
- TCP source and destination ports 133
- UDP source and destination ports 133
- VLAN ID 130
- Common and Internal Spanning Tree (CIST)
  - defined 260
  - priority 260
- common VLAN 81
- community names
  - SNMPv1 and SNMPv2c 90
- configuration file
  - described 71
- configuration name 257
- control messages, Ethernet Protection Switching Ring (EPSR) snooping 211
  - 213
- CoS. *See* Class of Service (CoS)
- CRL. *See* certificate revocation list (CRL)

**D**

- default route
  - described 334
  - examples 350, 353
- default settings, AT-S63 Management Software 463
- denial of service defenses
  - default settings 469
  - described 179
  - guidelines 188
  - IP options attack 186
  - land attack 182
  - mirror port 113
  - mirroring traffic 187
  - ping of death attack 185
  - smurf attack 181
  - supported platforms 178, 190
  - SYN flood attack 180
  - teardrop attack 184
- deny access control lists 137
- DES privacy protocol 223
- destination MAC addresses
  - in classifiers 129
- destination port in a port mirror 113
- Diffie-Hellman algorithm 420
- discovery process
  - described 68
- distinguished names 425
- document conventions 25
- DoS. *See* denial of service defenses
- dynamic GVRP port 285
- dynamic GVRP VLAN 285
- dynamic MAC addresses 94
- dynamic module ID numbers
  - described 70

**E**

- edge ports 243
- egress ports 310
- egress queues 149

- encryption (SSL) 429
- encryption keys
  - described 413, 431
  - guidelines 415
  - Secure Shell (SSH) 440
  - supported platforms 412
  - technical overview 416
- End Entity 433
- Engine ID, defined 222
- enhanced stacking 65
  - and Secure Sockets Layer (SSL) 427
  - and SSH 443
  - common VLAN 81
  - described 79
  - guidelines 85
  - local interface 82
  - master switches 80
  - slave switches 80
  - supported platforms 60, 78
- entities, defined 221
- EPSR snooping. *See* Ethernet Protection Switching Ring (EPSR) snooping
- Equal Cost Multi-path routing 335
- Ethernet 802.2 in classifiers 129
- Ethernet II frame types in classifiers 129
- Ethernet Protection Switching Ring (EPSR) snooping
  - default setting 473
  - described 211
  - guidelines 215
  - restrictions 213
  - supported platforms 210
- event logs
  - default settings 474
  - described 123
  - supported platforms 122
- event messages 123

**F**

- file system 118
- flow groups 160
- forwarding delay 242

**G**

- GARP VLAN Registration Protocol (GVRP)
  - default settings 475
  - described
  - guidelines 288
  - intermediate switches 290
  - network security 289
- GARP. *See* Generic Attribute Registration Protocol (GARP)
- Generic Attribute Registration Protocol (GARP) 291
- GVRP. *See* GARP VLAN Registration Protocol (GVRP)

**H**

- hello time 242
- history of new features 51
- HMAC authentication algorithm 419
- HMAC-MD5-96 (MD5) authentication protocol 222
- HMAC-SHA-96 (SHA) authentication protocol 222

HTTP 407  
 HTTPS 407

## I

IEEE 802.1D standard 235  
 IGMP snooping. *See* Internet Group Management Protocol (IGMP) snooping  
 interface monitoring 366  
 Internet Group Management Protocol (IGMP) snooping  
   default settings 476  
   described 199  
   supported platforms 198  
 Internet Protocol version 4 routing  
   *see also* routing interfaces, Routing Information Protocol (RIP), static routes  
   default settings 477  
   described 324  
   examples 348, 352  
   supported platforms 322  
 intrusion actions 377  
   *See also* MAC address-based port security  
 IP address, stack 74  
 IP configuration 47  
 IP destination addresses in classifiers 132  
 IP DSCP in classifiers 131  
 IP options attack 186  
 IP protocol in classifiers 132  
 IP source addresses in classifiers 132  
 IP Type of Service in classifiers 131

## K

key exchange algorithms 419

## L

LACP. *See* Link Aggregation Control Protocol (LACP) port trunk  
 land attack 182  
 limited port security mode 375  
 Link Aggregation Control Protocol (LACP) port trunk  
   adminkey parameter 107  
   aggregate trunks 105  
   aggregators 105  
   described 105  
   guidelines 109  
   load distribution methods 100, 108  
   port priority 107  
   system priority 106  
 load distribution methods  
   Link Aggregation Control Protocol (LACP) port trunk  
     100, 108  
   static port trunks 100  
 local interface 82, 345  
 local management session 43  
 locked port security mode 376

## M

MAC address table 94  
 MAC address-based port security  
   default settings 478

  described 375  
   guidelines 378  
   intrusion actions 377  
   levels 375  
 MAC address-based VLANs  
   described 309  
   egress ports 310  
   general steps 316  
   guidelines 317  
   multiple switches 313  
   supported platforms 308  
 management access control list  
   default setting 480  
   described 457  
   examples 460  
   guidelines 459  
   supported platforms 456  
 manager access levels 45  
 manager accounts 449  
 manager accounts, default settings 481  
 master switch 69  
   enhanced stacking 80  
   Virtual Router Redundancy Protocol (VRRP) 364  
 MD5 authentication algorithm 419  
 MD5 authentication protocol 222  
 member switches 69  
 MIB objects 513  
 MIB subtree view 225  
 MIB tree  
   diagram 224  
   RFC 224  
 MIB view 224  
 MIBs  
   supported 44, 513  
   viewing 221  
 mirroring traffic, denial of service defenses 187  
 MLD snooping. *See* Multicast Listener Discovery (MLD) snooping  
 module ID numbers  
   described 70  
 MSTI priority 259  
 MSTI. *See* Multiple Spanning Tree Instances (MSTI)  
 MSTP. *See* Multiple Spanning Tree Protocol (MSTP)  
 Multicast Listener Discovery (MLD) snooping  
   default settings 482  
   described 203  
   supported platforms 202  
 Multiple Spanning Tree Instances (MSTI) 250  
   guidelines 254  
   ports in multiple instances 256  
 Multiple Spanning Tree Protocol (MSTP)  
   associations 255  
   configuration name 257  
   connecting VLANs 265  
   default settings 491  
   described 249  
   diagram 252  
   MSTI priority, defined 259  
   regional root 259

- regions 257
- revision number 257
- with STP and RSTP 260

multiple VLAN modes 297

**N**

non-802.1Q compliant VLAN mode 300  
 none port role 384  
 nonvolatile storage, described 226

**O**

operator accounts, default settings 481

**P**

password, default 45  
 path cost 239  
 permit access control lists 137  
 ping of death attack 185  
 PKI. *See* Public Key Infrastructure (PKI)  
 Platforms 202  
 PoE. *See* Power over Ethernet  
 point-to-point ports 243  
 policies
 

- described 162
- guidelines 163

 port cost 239  
 port mirror
 

- described 113
- guidelines 113
- supported platforms 112

 port monitoring in Virtual Router Redundancy Protocol (VRRP) 367  
 port priority 240  
 port priority in aggregate trunks 107  
 port security. *See* 802.1x Port-based Network Access Control; MAC address-based port security  
 port trunks. *See* Link Aggregation Control Protocol (LACP)  
   port trunk; static port trunks  
 port VLAN identifier (PVID) 274  
 port-based access control. *See* 802.1x Port-based Network Access Control  
 port-based VLANs
 

- default settings 497
- described 273
- examples 276, 277
- guidelines 275
- supported platforms 270

 Power over Ethernet (PoE)
 

- described

 privacy 223  
 private encryption key. *See* encryption key  
 protected ports VLANs
 

- described 303
- guidelines 305
- supported platforms 302

 protocols in classifiers 130  
 public encryption key. *See* encryption key

**Public Key Infrastructure (PKI)**

*See also* certificates, encryption keys  
 certificate database 435  
 certificates
 

- adding 435
- fingerprint 435
- retrieving 435
- validating 434

 certification authority (CA)
 

- described 433
- root 434

 default settings 483  
 described 431  
 End Entity 433  
 standards 435  
 structure 433  
 supported platforms 422  
 X.509 certificates 432

PVID. *See* Port VLAN identifier (PVID)

**Q**

QoS. *See* Quality of Service (QoS)  
 Quality of Service (QoS)
 

- See also* traffic classes; flow groups; policies
- classifiers 127
- described 157
- supported platforms 156

**R****RADIUS**

default settings 487  
 described 449  
 guidelines 451  
 supported platforms 448

Rapid Spanning Tree Protocol (RSTP)  
 and VLANs 246  
 default settings 490  
 described 237  
 supported platforms 236

redundant twisted pair ports 49  
 regional root 259  
 regions 257  
 revision number 257

RJ-45 serial terminal port, default settings 485  
 root bridge 238

Router Redundancy Protocol (RRP) snooping  
 default setting 486  
 described 207  
 guidelines 208  
 supported platforms 206

Routing Information Protocol (RIP) 332  
 routing interface names 329  
 routing interface numbers 327  
 routing interfaces
 

- and enhanced stacking 343
- and network servers 342
- and remote management 343
- described 326



routing table 337  
RRP snooping. *See* Router Redundancy Protocol (RRP) snooping

## S

scheduling, Class of Service 152

Secure Shell (SSH)

- and enhanced stacking 443
- AT-S63 implementation 440
- ciphers 440
- clients, described 442
- configuration overview 446
- default settings 492
- described 439
- encryption algorithms 440
- encryption keys 440
- server 441
- supported platforms 438

Secure Sockets Layer (SSL)

- See also* certificates, encryption key
- and enhanced stacking 427
- default settings 493
- described 423
- encryption 429
- supported platforms 422
- technical overview 429

secured port security mode 376

self-signed certificate 423

server-based authentication. *See* RADIUS, TACACS+

SHA authentication algorithm 419

SHA authentication protocol 222

Simple Network Time Protocol (SNTP)

- default settings 489

smurf attack 181

SNMP community strings

- access mode 90
- closed access status 90
- default 92
- name 90
- open access status 90
- operating status 90
- trap receivers 90

SNMP management sessions 44

SNMP, default settings 488

SNMPv1 and SNMPv2c

- agent 221
- community names 90
- described 89
- manager 221
- supported platforms 88

SNMPv1 protocol 221

SNMPv2c protocol 221

SNMPv3 Access Table, described 230

SNMPv3 Community Table, described 231

SNMPv3 Engine ID, defined 222

SNMPv3 entities 221

SNMPv3 Notify Table, described 231

SNMPv3 protocol

- authentication protocols 222

Configure SNMPv3 Community Table 231

Engine ID 222

message notification 227

MIB views 224

overview 221

privacy protocols 223

SNMPv3 Access Table 230

SNMPv3 Notify Table 231

SNMPv3 SecurityToGroup Table 230

SNMPv3 Target Address Table 231

SNMPv3 Target Parameters Table 231

storage types 226

supported platforms 220

tables 228

User Table 230

View Table 230

SNMPv3 SecurityToGroup Table, described 230

SNMPv3 Target Address Table, described 231

SNMPv3 Target Parameters Table, described 231

SNMPv3 trap 227

SNMPv3 User Table, described 230

SNMPv3 View Table, described 230

source MAC addresses

- in classifiers 129

source ports in a port mirror 113

Spanning Tree Protocol (STP)

- and VLANs 246

- default settings 490

- described 237

- supported platforms 236

split horizon 333

split horizon with poison reverse 333

SSH. *See* Secure Shell (SSH)

SSL. *See* Secure Sockets Layer (SSL)

stacking

- maximum number of switches 64

- topology 66

static MAC addresses 95

static module ID numbers

- described 70

static port trunks

- described

- guidelines 102

- load distribution methods 100

- supported platforms 98

static routes 330

strict priority scheduling 152

subtree mask, related to MIB subtree view 225

supplicant port role 381, 386

supported features 30

SYN flood attack 180

syslog client 124

system priority in aggregate trunks 106

## T

TACACS+

- default settings 487

- described 449

- guidelines 451

- supported platforms 448
- tagged ports 280
- tagged VLANs
  - default settings 497
  - described 279
  - example 281
  - guidelines 280
  - supported platforms 270
- TCP destination ports in classifiers 133
- TCP flags in classifiers 133
- TCP source ports in classifiers 133
- teardrop attack 184
- Telnet management sessions 43
- Telnet server 43
  - default settings 495
- traffic classes 161
- traffic flow, described 127
- trap receivers 90
- Triple DES (3DES) encryption algorithms 417

## U

- UDP destination ports 133
- UDP destination ports in classifiers 133
- UDP source ports 133
- UDP source ports in classifiers 133
- untagged ports 274
- User-based Security Model (USM) authentication 221
- username, default 45

## V

- Virtual LAN. *See* MAC address-based VLANs, multiple VLAN modes, port-based VLANs, protected ports VLANs, tagged VLANs
- Virtual Router Redundancy Protocol (VRRP)
  - backup switches 365
  - default settings 496
  - described 363
  - interface monitoring 366
  - master switch 364
  - port monitoring 367
  - supported platforms 362
- VLAN and MSTI associations 255
- VLAN ID 273
  - in classifiers 130
- volatile storage 226
- VRRP. *See* Virtual Router Redundancy Protocol (VRRP)

## W

- web browser management sessions 44
- web server 407
  - default settings 498
  - overview 407
- weighted round robin priority scheduling 152
- wildcards, in file names 120

## X

- X.509
  - certificate 432
  - specification 432