

x600 Series Layer 3 Gigabit Ethernet Switches

x600-24Ts
x600-24Ts/XP
x600-48Ts
x600-48Ts/XP

Installation Guide

Copyright © 2009 Allied Telesis, Inc.

All rights reserved. No part of this publication may be reproduced without prior written permission from Allied Telesis, Inc.

Allied Telesis, Alliedware Plus and the Allied Telesis logo are trademarks of Allied Telesis, Incorporated. All other product names, company names, logos or other designations mentioned herein are trademarks or registered trademarks of their respective owners.

Allied Telesis, Inc. reserves the right to make changes in specifications and other information contained in this document without prior written notice. The information provided herein is subject to change without notice. In no event shall Allied Telesis, Inc. be liable for any incidental, special, indirect, or consequential damages whatsoever, including but not limited to lost profits, arising out of or related to this manual or the information contained herein, even if Allied Telesis, Inc. has been advised of, known, or should have known, the possibility of such damages.

Preface

This guide contains the installation instructions for the x600 Series Layer 3 Gigabit Ethernet Switches. This preface contains the following sections:

- “Product Documentation” on page 4
- “Starting a Management Session” on page 5
- “Safety Symbols Used in this Document” on page 6
- “Where to Find Web-based Guides” on page 7
- “Contacting Allied Telesis” on page 8

Product Documentation

For overview information about the software features of the *AlliedWare Plus Operating System Software* which runs on the x600 Series Switches, refer to:

- *AlliedWare Plus Operating System Software Reference Guide*
- *Virtual Chassis Stacking (VCS) How To Note*
- *AT-StackXG Stacking Module Installation Guide*



Starting a Management Session

For instructions that describe how to start a local management session on an x600 switch, refer to the “Starting a Local Management Session” on page 75. For information that describes how to log onto the AlliedPlus™ Operating System Software, see the *AlliedWare Plus Operating System Software Reference Guide*.

Safety Symbols Used in this Document

This document uses the safety symbols defined in Table 1.

Table 1. Safety Symbols

Symbol	Meaning	Description
	Caution	Performing or omitting a specific action may result in equipment damage or loss of data.
	Warning	Performing or omitting a specific action may result in electrical shock.

Where to Find Web-based Guides

The installation and user guides for all Allied Telesis products are available in portable document format (PDF) on our web site at **www.alliedtelesis.com**. You can view the documents online or download them onto a local workstation or server.

Contacting Allied Telesis

This section provides Allied Telesis contact information for technical support as well as sales and corporate information.

Online Support

You can request technical support online by accessing the Allied Telesis Knowledge Base at **www.alliedtelesis.com/support** and selecting the “Read More” link under Knowledge Base. You can use the Knowledge Base to submit questions to our technical support staff and review answers to previously asked questions.

Email and Telephone Support

For Technical Support via email or telephone, refer to the Support section of the Allied Telesis web site: **www.alliedtelesis.com**.

Warranty

For warranty information on the x600 Series Layer 3 Gigabit Ethernet Switches, go to **www.alliedtelesis.com/warranty** for the specific terms and conditions of the warranty and for warranty registration.

Returning Products

Products for return or repair must first be assigned a return materials authorization (RMA) number. A product sent to Allied Telesis without an RMA number will be returned to the sender at the sender’s expense. For instructions on how to obtain an RMA number, go to the Support section on our web site at **www.alliedtelesis.com**.

Sales or Corporate Information

You can contact Allied Telesis for sales or corporate information through our web site at **www.alliedtelesis.com**.

Management Software Updates

New releases of the management software for our managed products are available from the following Internet sites:

- Allied Telesis web site: **www.alliedtelesis.com**
- Allied Telesis FTP server: **<ftp://ftp.alliedtelesis.com>**

If the FTP server prompts you to log on, enter “anonymous” as the user name and your email address as the password.

Electrical Safety and Emissions Standards

This product meets the following standards.

U.S. Federal Communications Commission

Radiated Energy

Note: This equipment has been tested and found to comply with the limits for a Class A digital device pursuant to Part 15 of FCC Rules. These limits are designed to provide reasonable protection against harmful interference when the equipment is operated in a commercial environment. This equipment generates, uses, and can radiate radio frequency energy and, if not installed and used in accordance with this instruction manual, may cause harmful interference to radio communications. Operation of this equipment in a residential area is likely to cause harmful interference in which case the user will be required to correct the interference at his own expense.

Note: Modifications or changes not expressly approved of by the manufacturer or the FCC, can void your right to operate this equipment.

Industry Canada

This Class A digital apparatus complies with Canadian ICES-003.

Cet appareil numérique de la classe A est conforme à la norme NMB-003 du Canada.

RFI Emissions FCC Class A, EN55022 Class A, EN61000-3-2, EN61000-3-3, VCCI Class A, C-TICK, CE



Warning

In a domestic environment this product may cause radio interference in which case the user may be required to take adequate measures.

EMC (Immunity) EN55024

Electrical Safety EN60950-1 (TUV), EN60825-1 (TUV), UL 60950-1 (CULUS), CSA-C22-2 No. 60950-1 (CULUS)



Laser Safety EN60825

Translated Safety Statements

Important: The  indicates that a translation of the safety statement is available in a PDF document titled “Translated Safety Statements” (613-000990) posted on the Allied Telesis website at www.alliedtelesis.com.

Contents

Preface	3
Product Documentation	4
Starting a Management Session	5
Safety Symbols Used in this Document	6
Where to Find Web-based Guides	7
Contacting Allied Telesis	8
Online Support	8
Email and Telephone Support.....	8
Warranty.....	8
Returning Products	8
Sales or Corporate Information	8
Management Software Updates.....	8
Chapter 1: Overview	17
Introduction.....	18
Switch Descriptions	19
x600-24Ts Switch.....	19
x600-24Ts/XP Switch.....	20
x600-48Ts Switch.....	21
x600-48Ts/XP Switch.....	22
10/100/1000Base-T Twisted Pair Ports.....	23
Connector Type.....	23
Speed.....	23
Duplex Mode.....	23
Maximum Distance.....	23
Cable Type.....	24
Auto-MDI/MDI-X.....	24
Port Pinouts.....	24
SFP Transceiver Slots.....	25
XFP Transceiver Slots.....	26
Redundant Twisted Pair Ports.....	27
SD Card Slot.....	28
Port LEDs	29
10/100/1000Base-T Twisted Pair Port LEDs	29
SFP LEDs	30
XFP Transceiver Slot LEDs	30
System Status LEDs.....	31
Stack LEDs.....	32
Terminal Port.....	34
AT-RPS3204 Redundant Power Supply.....	35
AT-LBM (Loop Back) Module	36
VCS Stacking Module.....	37
AC Power Connector.....	38

Chapter 2: Virtual Chassis Stacking	39
VCStack™ Introduction	40
Features of VCStacking.....	40
The Physical Stack	40
Resiliency Link.....	42
VCStack Recovery States	42
Resiliency Link Configurations via Switch Ports.....	44
Resilient Stacked Topology	45
Stack Formation	46
The Role of the Stack Master	46
Stack Member Failure and Recovery	49
VCS Failure Recovery	50
Stack Maintenance	51
Chapter 3: Installing the Hardware	53
Reviewing Safety Precautions	54
Unpacking a Switch	56
Installing the Power Cord Retaining Clip	57
Installing the Switches in an Equipment Rack	58
Resetting the Switch	60
AT-StackXG Module Installation	61
Overview.....	61
Preparation	61
Installing the AT-StackXG Module.....	62
Chapter 4: Cabling the Network Ports	65
Twisted Pair and Fiber Optic Cable Specifications	66
Twisted Pair Cable Specifications	66
SFP/XFP Transceiver Cable Specifications	67
Installing SFP/XFP Transceivers	68
Installing an SFP Transceiver.....	68
Installing an XFP Transceiver.....	71
Cabling the Twisted Pair and Fiber Optic Ports	73
Powering on a Switch	74
Starting a Local Management Session.....	75
Warranty Registration	76
Chapter 5: Troubleshooting	77
Power LED is Off	78
Twisted Pair Port Link LED is Off.....	79
SFP or XFP LED is Off	80
Transceiver is Installed but the Status is “Not Present”	81
System Fault LED is Blinking.....	82
System Fault LED is Steadily On	83
Cannot Establish a Local (Out-of-Band) Management Session.....	84
Switch Functions Intermittently	85
Issues with Virtual Stacking Chassis Configuration	86
Appendix A: Technical Specifications	87
Physical Specifications	87
Environmental Specifications.....	87
Power Specifications.....	88
Certifications	88
RJ-45 Twisted Pair Port Pinouts	89
RJ-45 Style Serial Terminal Port Pinouts.....	91
RPS 21-pin D-combo Port and Connector Pinouts.....	92

List of Figures

Figure 1. x600-24Ts Switch - Front and Rear Panels.....	19
Figure 2. x600-24Ts/XP Switch - Front and Rear Panel.....	20
Figure 3. x600-48Ts Switch - Front and Rear Panel.....	21
Figure 4. x600-48Ts/XP Switch - Front and Rear Panel.....	22
Figure 5. SFP Transceiver.....	25
Figure 6. XFP Transceiver.....	26
Figure 7. SD Card Slot.....	28
Figure 8. SD Card.....	28
Figure 9. Port LEDs on an x600-24Ts/XP Switch.....	29
Figure 10. System Status LEDs.....	31
Figure 11. Stack LEDs.....	32
Figure 12. AT-RPS3204 Redundant Power Supply Unit.....	35
Figure 13. AT-LBM Module installed in x600-48Ts/XP Expansion Slot.....	36
Figure 14. VCS Stacking Module (AT-StackXG).....	37
Figure 15. Back-to-Back Topology (x600 Switches).....	41
Figure 16. VCS Ring Topology Using x600 Switches.....	42
Figure 17. Resiliency link connecting to switch ports over the ResiliencyLink VLAN.....	44
Figure 18. Resiliency link connecting to switch ports over the ResiliencyLink VLAN using a network hub.....	44
Figure 19. VCS Stacking Module.....	46
Figure 20. Stack and Status LEDs.....	48
Figure 21. Power Cord Retaining Clip.....	57
Figure 22. Inserting the Retaining Clip into the Retaining Bracket.....	57
Figure 23. Removing the Feet.....	58
Figure 24. Attaching Rack-Mount Brackets.....	59
Figure 25. Mounting the Switch in a Rack.....	59
Figure 26. Resetting the Switch.....	60
Figure 27. AT-StackXG Module.....	61
Figure 28. Removing the Blank Panel from the Expansion Slot.....	62
Figure 29. Installing the AT-StackXG Stacking Module.....	63
Figure 30. Securing the AT-StackXG Stacking Module.....	63
Figure 31. Removing the Plastic Protector.....	64
Figure 32. Removing a Dust Plug from an SFP Slot.....	68
Figure 33. Installing an SFP Transceiver.....	69
Figure 34. Positioning Handles on the x600-24Ts and x600-24Ts/XP Switches.....	69
Figure 35. Positioning SFP Handles on the x600-48Ts and x600-48Ts/XP Switches.....	70
Figure 36. Removing an XFP Dust Plug.....	71
Figure 37. Installing an XFP Transceiver.....	71
Figure 38. Power Cord Retaining Clip in the Up Position.....	74
Figure 39. Connecting the AC Power Cord.....	74
Figure 40. Connecting the Management Cable to the RJ-45 Terminal Port on the Switch.....	75
Figure 41. RJ-45 Connector and Port Pin Layout.....	89
Figure 42. RPS 21-pin D-combo Connector and Port Pin Layout.....	92

List of Tables

Table 1. Safety Symbols	6
Table 2. Twisted Pair Ports Matched with SFP Slots	27
Table 3. Twisted Pair Port LEDs	29
Table 4. SFP Slot LED	30
Table 5. XFP Slot LED	30
Table 6. System Status LEDs	31
Table 7. STACK LEDs	32
Table 8. Secure Digital LED	33
Table 9. Stacking Compatibility by Product Type	40
Table 10. State Change Table	43
Table 11. Stacking LED Functions	49
Table 12. Twisted Pair Cabling and Distances	66
Table 13. MDI Pin Signals - 10 or 100 Mbps	89
Table 14. MDI-X Pin Signals - 10 or 100 Mbps	89
Table 15. Pin Signals - 1000 Mbps	90
Table 16. RJ-45 Style Serial Terminal Port Pin Signals	91
Table 17. RPS 21-pin Connector Pin Definitions	92

Chapter 1

Overview

This chapter contains the following sections:

- ❑ “Introduction” on page 18
- ❑ “Switch Descriptions” on page 19
- ❑ “10/100/1000Base-T Twisted Pair Ports” on page 23
- ❑ “SFP Transceiver Slots” on page 25
- ❑ “XFP Transceiver Slots” on page 26
- ❑ “Redundant Twisted Pair Ports” on page 27
- ❑ “SD Card Slot” on page 28
- ❑ “Port LEDs” on page 29
- ❑ “System Status LEDs” on page 31
- ❑ “Stack LEDs” on page 32
- ❑ “Terminal Port” on page 34
- ❑ “AT-RPS3204 Redundant Power Supply” on page 35
- ❑ “AT-LBM (Loop Back) Module” on page 36
- ❑ “VCS Stacking Module” on page 37
- ❑ “AC Power Connector” on page 38

Note

Do not begin the installation procedures in this guide until you have read the *AlliedWare Plus Operating System Software Release Notes* that are included with the latest release of the *AlliedWare Plus Operating System Software*.

Introduction

The x600 Series Switches are managed Gigabit Ethernet switches that act as standalone units. There are four Basic Layer 3 switches in the series:

- ❑ x600-24Ts Switch
- ❑ x600-24Ts/XP Switch
- ❑ x600-48Ts Switch
- ❑ x600-48Ts/XP Switch

The x600-24Ts and the x600-24Ts/XP switches both have 24 10/100/1000Base-T ports. The x600-48Ts and the x600-48Ts/XP switches both have 44 10/100/1000 Base-T ports.

All four switches have four SFP transceiver slots, a Secure Digital (SD) card slot, a console port, and a redundant power supply connector. In addition, the x600-24Ts/XP and the x600-48Ts/XP switches have two XFP transceiver slots.

On the back of all the switches there is an AC power connector, an RPS connector, and an expansion slot. You can connect the RPS connector to the AT-RPS3204 Redundant Power Supply. The x600 switches are shipped with a blank expansion slot with the exception of the The x600-48Ts/XP switch which is shipped with an AT-LBM (Loop Back) module installed in the expansion slot.

The *AlliedWare Plus Operating System Software* runs on all the x600 switches.

For more detailed information about the switches, including illustrations, see “Switch Descriptions” on page 19.

Switch Descriptions

The following sections describe the x600-24Ts, x600-24Ts/XP, x600-48Ts, x600-48Ts/XP Series Layer 3 Gigabit Ethernet Switches.

x600-24Ts Switch

The x600-24Ts switch has the following hardware features:

- ❑ 24 10/100/1000Base-T ports
- ❑ Four Gigabit Ethernet small form-factor pluggable (SFP) transceiver slots
- ❑ An RJ-45 style serial terminal port for local (out-of-band) management
- ❑ One SD slot supporting 512KB and 1GB SD cards
- ❑ Status LEDs for the ports, transceiver slots, and system
- ❑ Redundant power supply connector
- ❑ Expansion slot for the AT-StackXG Stacking Module

Figure 1 shows the front and rear panel views of the x600-24Ts switch.

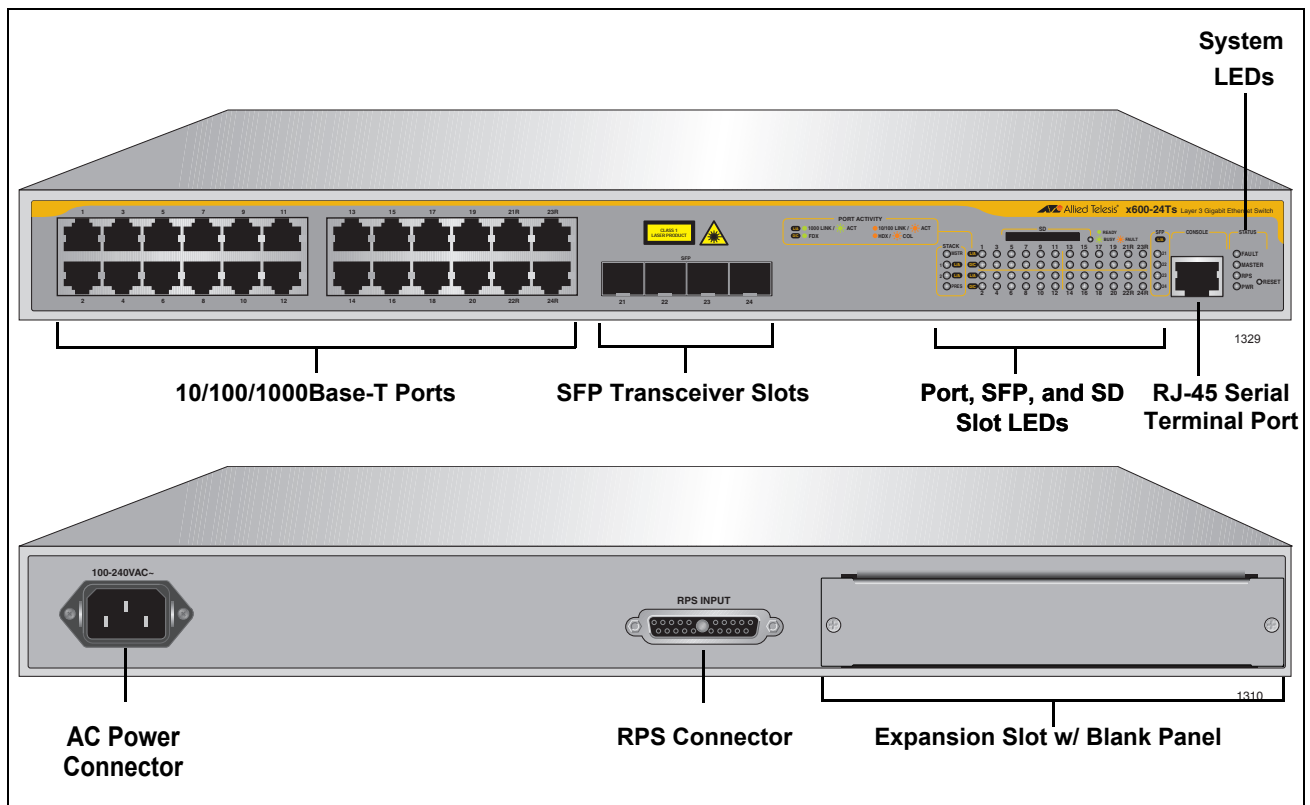

Figure 1. x600-24Ts Switch - Front and Rear Panels

x600-24Ts/XP Switch

The x600-24Ts/XP switch has the following hardware features:

- ❑ 24 10/100/1000Base-T ports
- ❑ Four Gigabit Ethernet small form-factor pluggable (SFP) transceiver slots
- ❑ Two 10 Gigabit Ethernet small form factor pluggable (XFP) transceiver slots
- ❑ An RJ-45 style serial terminal port for local (out-of-band) management
- ❑ One SD slot supporting 512KB and 1GB SD cards
- ❑ Status LEDs for the ports, transceiver slots, and system
- ❑ Redundant power supply connector
- ❑ Expansion slot for the AT-StackXG Stacking Module

Figure 2 shows the front and rear panel views of the x600-24Ts/XP switch.

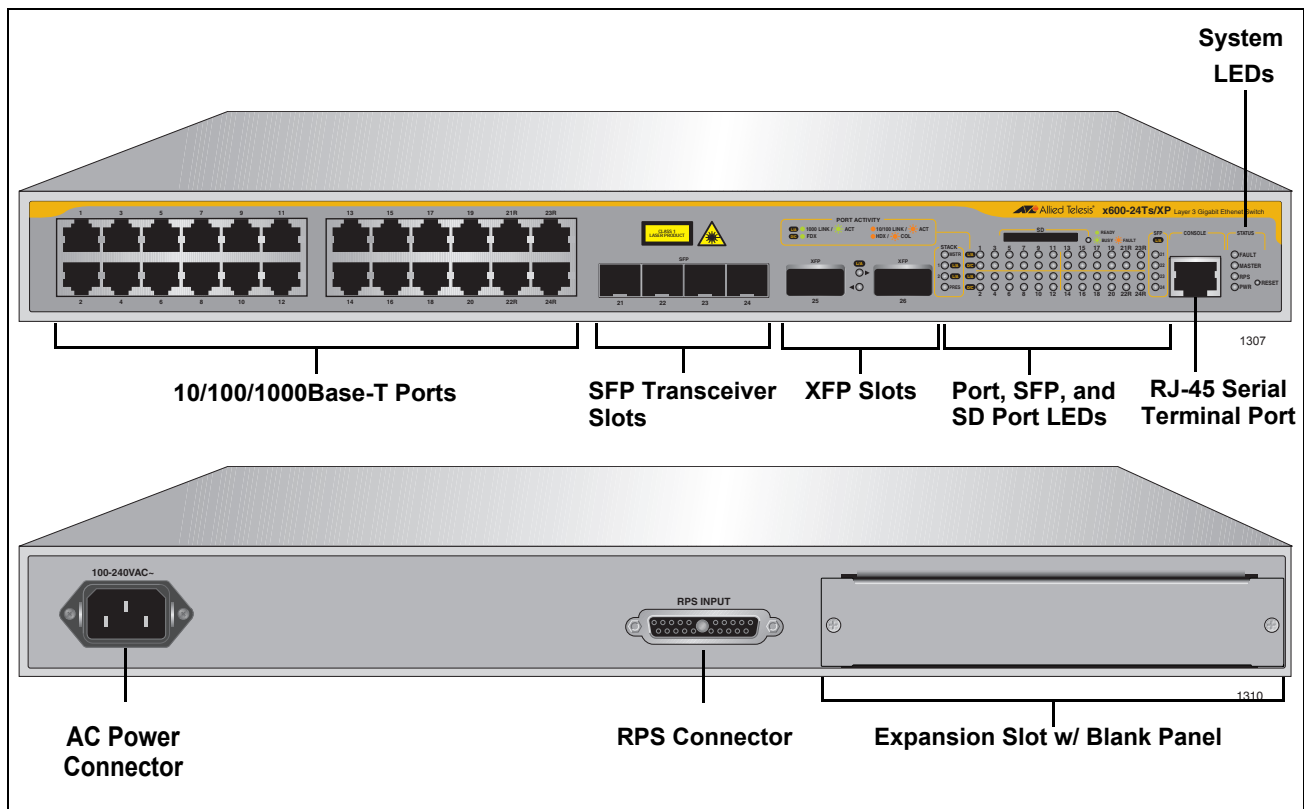

Figure 2. x600-24Ts/XP Switch - Front and Rear Panel

x600-48Ts Switch

The x600-48Ts switch has the following hardware features:

- ❑ 44 10/100/1000Base-T ports
- ❑ Four Gigabit Ethernet small form-factor pluggable (SFP) transceiver slots
- ❑ An RJ-45 style serial terminal port for local (out-of-band) management
- ❑ One SD slot supporting 512KB and 1GB SD cards
- ❑ Status LEDs for the ports, transceiver slots, and system
- ❑ Redundant power supply connector
- ❑ Expansion slot for the AT-StackXG Stacking Module

Figure 3 shows the front and rear panel views of the x600-48Ts switch.

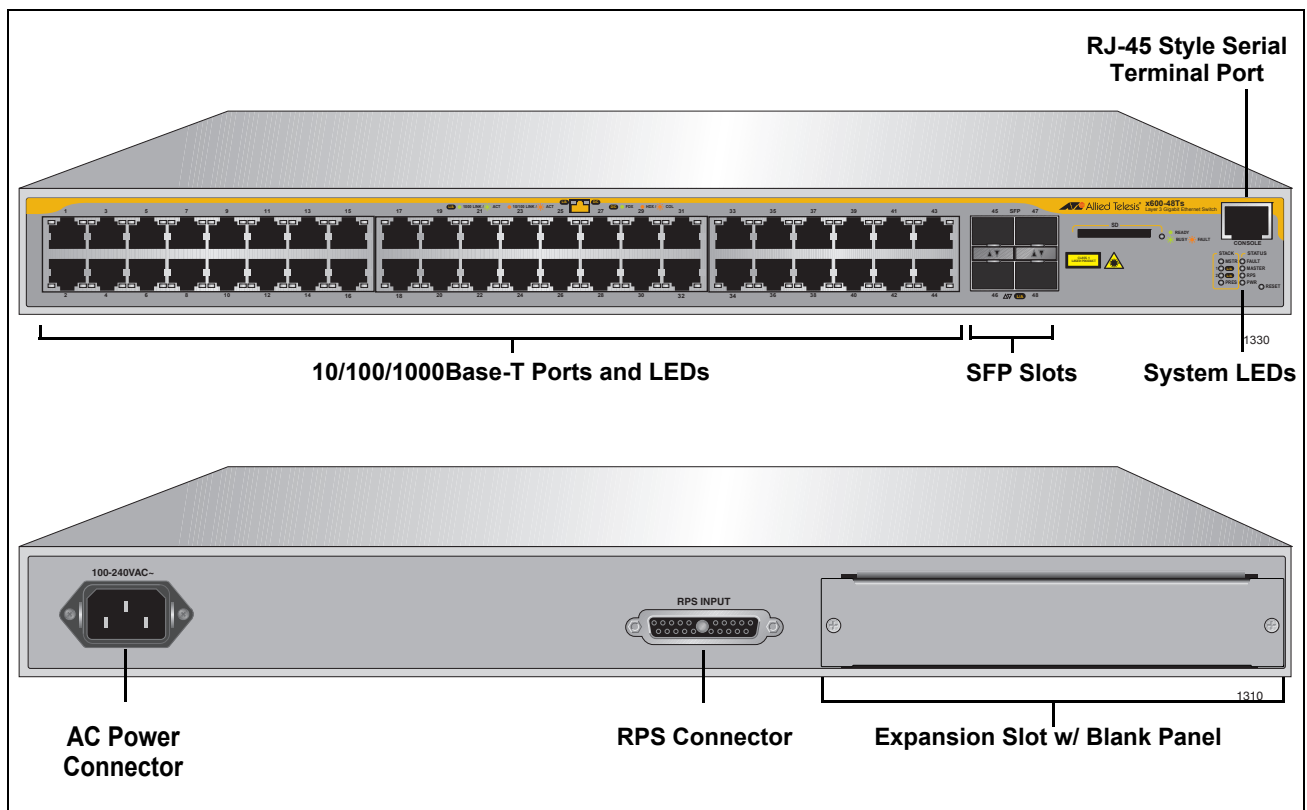

Figure 3. x600-48Ts Switch - Front and Rear Panel

x600-48Ts/XP Switch

The x600-48Ts/XP switch has the following hardware features:

- ❑ 44 10/100/1000Base-T ports
- ❑ Four Gigabit Ethernet small form-factor pluggable (SFP) transceiver slots
- ❑ Two 10 Gigabit Ethernet small form factor pluggable (XFP) transceiver slots
- ❑ An RJ-45 style serial terminal port for local (out-of-band) management
- ❑ One SD slot supporting 512KB and 1GB SD cards
- ❑ Status LEDs for the ports, transceiver slots, and system
- ❑ Redundant power supply connector
- ❑ AT-LBM (Loop Back) module installed in the rear of the switch

Figure 4 shows the front and rear panel views of the x600-48Ts/XP switch.

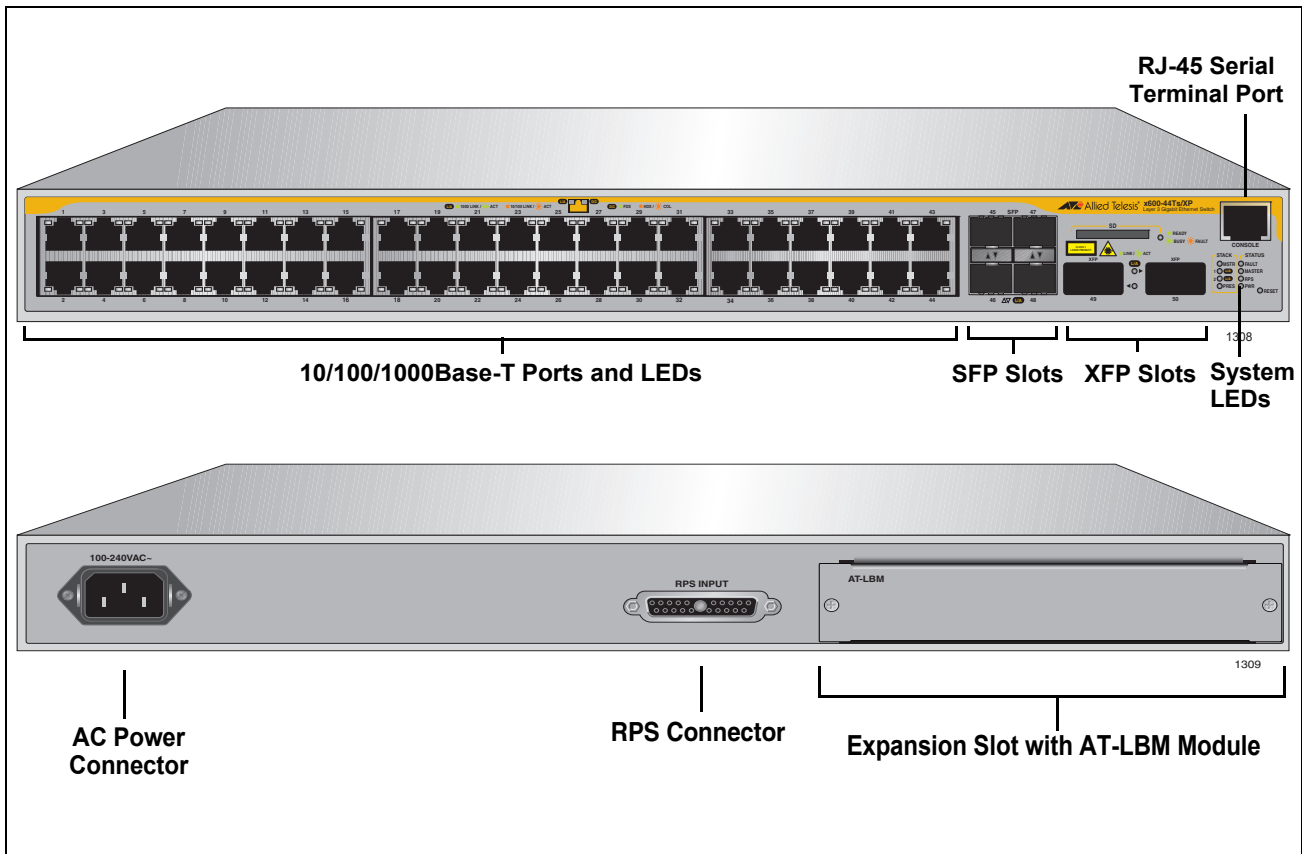

Figure 4. x600-48Ts/XP Switch - Front and Rear Panel

10/100/1000Base-T Twisted Pair Ports

This section describes the twisted pair ports on the switches.

Connector Type The ports are 8-pin RJ-45 connectors that use four pins at 10 or 100 Mbps and all eight pins at 1000 Mbps. For the pin assignments, refer to “RJ-45 Twisted Pair Port Pinouts” on page 89.

Speed A port’s speed can be 10, 100, or 1000 Mbps. The speed can be set automatically through Auto-Negotiation, the default setting, or manually with the *AlliedWare Plus Operating System Software*.

Duplex Mode A twisted pair port can operate in either half- or full-duplex mode. (Full-duplex mode is the only mode available when a port is operating at 1000 Mbps.) The twisted pair ports are IEEE 802.3u-compliant and Auto-Negotiate the duplex mode setting.

You can disable Auto-Negotiation on one or all of the switch ports so that you can set the duplex mode manually through the *AlliedWare Plus Operating System Software*.

Note

In order for a switch port to successfully Auto-Negotiate its duplex mode with a 10 or 100 Mbps end node, the end node must be configured for Auto-Negotiation. Otherwise, a duplex mode mismatch can occur. A switch port using Auto-Negotiation defaults to half-duplex if it detects that the end node is not using Auto-Negotiation. This results in a mismatch if the end node is operating at a fixed duplex mode of full-duplex.

To avoid this problem when connecting an end node with a fixed duplex mode of full-duplex to a switch port, use the *AlliedWare Plus Operating System Software* to disable Auto-Negotiation on the port and set the port speed and duplex mode manually.

Please be aware that disabling Auto-Negotiation will also disable Auto-MDI/MDIX and the port’s wiring configuration defaults to the MDI-X setting. This setting can be configured with the *AlliedWare Plus Operating System Software*.

Maximum Distance The ports have a maximum operating distance of 100 meters (328 feet).

Cable Type

The cabling requirements for a 10/100/1000Base-T port are:

- ❑ For 10 Mbps operation: Standard TIA/EIA 568-B-compliant Category 3 or better shielded or unshielded cabling with 100 ohm impedance and have a frequency range that extends to 16 MHz.
- ❑ For 100 Mbps operation: Standard TIA/EIA 568-A-compliant Category 5 or TIA/EIA 568-B-compliant Enhanced Category 5 (Cat 5e) shielded or unshielded cabling with 100 ohm impedance and have a frequency range that extends to 100 MHz.
- ❑ For 1000 Mbps operation: Standard TIA/EIA 568-A-compliant Category 5 or TIA/EIA 568-B-compliant Enhanced Category 5 (Cat 5e) shielded or unshielded cabling with 100 ohm impedance and have a frequency range that extends to 100 MHz.

Auto-MDI/ MDI-X

The twisted pair ports on the switch are IEEE 802ab-compliant and feature auto-MDI/MDI-X. This feature, available when a port's speed and duplex mode are set through Auto-Negotiation, automatically configures a switch port to MDI or MDI-X depending on the wiring configuration of the port on the end node. This allows you to connect any network device to a port on the switch using a straight-through twisted pair cable.

Disabling Auto-Negotiation on a port and setting the speed and duplex mode manually also disables the auto-MDI/MDI-X feature. A port where Auto-Negotiation has been disabled defaults to MDI-X. Disabling Auto-Negotiation may require manually configuring a port's MDI/MDI-X setting or using a crossover cable.

Port Pinouts

Refer to Table 12 on page 89 for the port pinouts when a twisted pair port operates at 10 or 100 Mbps in the MDI configuration and Table 13 on page 89 for the MDI-X configuration. For port pinouts when a twisted pair port operates at 1000 Mbps, refer to Table 14 on page 90.

SFP Transceiver Slots

All of the x600 Series switches feature slots for four optional Gigabit Ethernet SFP transceivers that interconnect network devices over large distances using fiber optic cable. SFP transceivers are also available with a copper cable interface allowing a host device designed primarily for optical fiber communications to also communicate over unshielded twisted pair networking cable. Figure 5 illustrates an SFP transceiver.

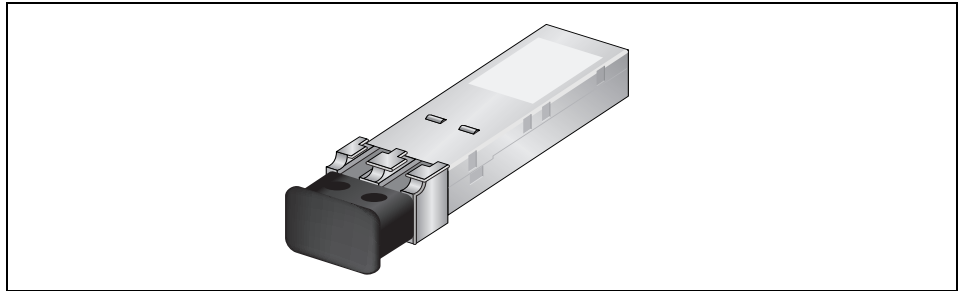

Figure 5. SFP Transceiver

Refer to “Installing an SFP Transceiver” on page 68 for the SFP installation instructions.

Note

For a list of supported SFP transceivers, contact your Allied Telesis sales representative.

XFP Transceiver Slots

The x600-24Ts/XP and the x600-48Ts/XP Switches have two slots for optional XFP 10 Gigabit Ethernet transceivers to connect high speed, 10 gigabit devices to the switch or create high speed backbone networks between switches.

Figure 6 shows an example of an XFP transceiver.

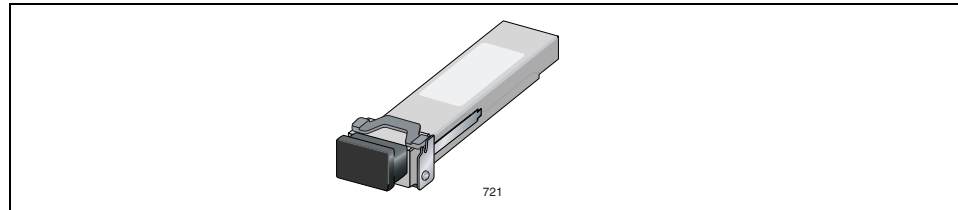

Figure 6. XFP Transceiver

Refer to “Installing an XFP Transceiver” on page 71 for the SFP installation instructions.

Note

For a list of supported XFP transceivers, contact your Allied Telesis sales representative.

Redundant Twisted Pair Ports

Four of the twisted pair ports on the x600-24-Ts and x600-24-Ts/XP switches are paired with SFP slots. The twisted pair ports are identified with the letter “R” for “Redundant” as part of their number on the faceplate of the unit. The ports and slots are listed in Table 1.

Table 1. Twisted Pair Ports Matched with SFP Slots

Models	Ports and Slots
x600-24Ts and x600-24Ts/XP	21R with SFP slot 21 22R with SFP slot 22 23R with SFP slot 23 24R with SFP slot 24

Follow these guidelines when using these ports and slots:

- ❑ Only one port in a pair can be active at a time. It can be either the twisted pair port or the corresponding SFP module.
- ❑ The twisted pair port is the active port when its SFP slot is empty, or when the SFP module is installed but has not established a link to the end node.
- ❑ The twisted pair port automatically changes to the redundant status mode when the SFP module establishes a link with the end node.
- ❑ The twisted pair port automatically transitions back to the active status when the link is lost on the SFP module.
- ❑ In nearly all cases, the twisted pair port and the SFP module share the same configuration settings, including port settings, VLAN assignments, access control lists, and Spanning Tree Protocol settings.
- ❑ An exception to the shared settings is port speed. If you disable Auto-Negotiation on the twisted pair port and set the speed and duplex mode manually, the speed reverts to Auto-Negotiation when the SFP module establishes a link with the end node.

SD Card Slot

All of the x600 Series Switches have an SD card slot which is designed for an SD card which stores configuration files and *AlliedWare Plus Operating System Software* image files. See Figure 7.

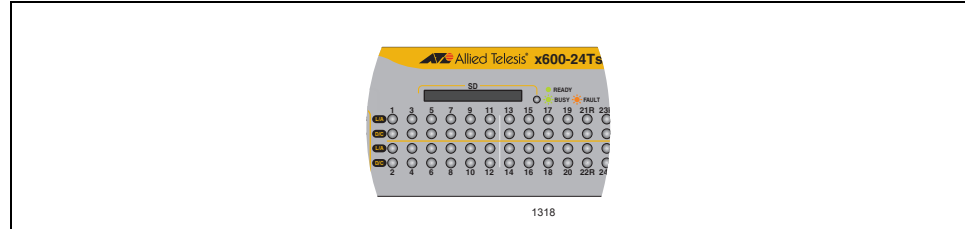

Figure 7. SD Card Slot

An SD card can make it easier for you to upgrade the files on a switch or transfer files between x600 switches. See Figure 8.



Figure 8. SD Card

Note

An SD card is not required for normal operations of the switch.

The x600 switches support various SD cards that are available from many vendors.

To insert an SD card, position it so that the manufacturer's brand label is facing up and press it into the slot until it is flush with the front of the chassis. The SD card is self-ejecting. To remove the SD card, press the card toward the x600 switch and the SD card pops out.

For information on how to transfer files to and from a SD card, refer to the *AlliedWare Plus Operating System Software Reference Guide*.

Port LEDs

The following sections describe the twisted pair port, SFP, and XFP LEDs. See Figure 9 for an illustration of the port LEDs on an x600-24Ts/XP.

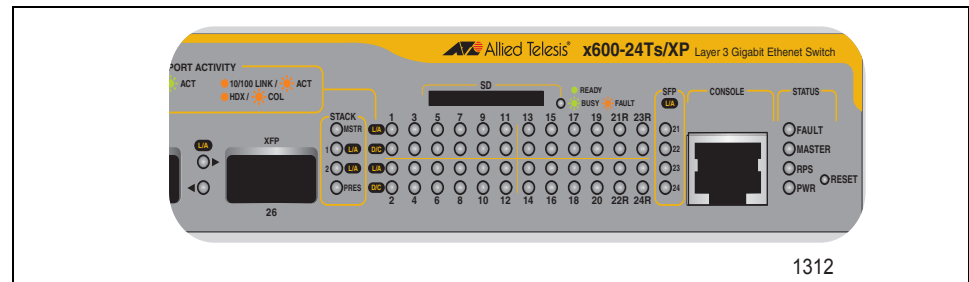

Figure 9. Port LEDs on an x600-24Ts/XP Switch

10/100/1000Base-T Twisted Pair Port LEDs

A twisted pair port has two LEDs labeled L/A (link/activity) and D/C (duplex mode/collisions). The L/A LED indicates the speed and activity on a port. The D/C LED indicates the duplex mode (full- or half-duplex) and the status of collisions on the port.

The twisted pair port LEDs appear on the right side of the x600-24Ts and x600-24Ts/XP faceplates. On the x600-48Ts and x600-48Ts/XP faceplates, the twisted pair port LEDs are interspersed among the twisted pair ports.

Table 2 describes the LEDs for the 10/100/1000Base-T twisted pair ports.

Table 2. Twisted Pair Port LEDs

LED	Function	State	Description
L/A	Link Status and Activity	Off	No link has been established between the port and the end node.
		Green	The port has established a link at 1000 Mbps.
		Flashing green	Packets are being received or transmitted at 1000 Mbps.
		Amber	The port has established a link at 10 or 100 Mbps.
		Flashing amber	Packets are being received or transmitted at 10 or 100 Mbps.

Table 2. Twisted Pair Port LEDs (Continued)

LED	Function	State	Description
D/C	Duplex Mode and Collisions	Green	The port is operating in full-duplex mode.
		Amber	The port is operating in half-duplex mode (only applies when operating at 10 or 100 Mbps).
		Flashing amber	Collisions are occurring on the port (only applies when operating at 10 or 100 Mbps, half duplex mode).

SFP LEDs

Each SFP transceiver slot on the x600 switches has one LED, defined in Table 3.

Table 3. SFP Slot LED

LED	Function	State	Description
L/A	Link Status and Activity	Off	No link has been established between the port and the end node.
		Green	The port has established a link at 1 Gbps.
		Flashing green	Packets are being received or transmitted at 1 Gbps.

XFP Transceiver Slot LEDs

Each 10 Gigabit Ethernet transceiver slot on the x600-24Ts/XP and x600-48Ts/XP switches has one LED, defined in Table 4.

Table 4. XFP Slot LED

LED	Function	State	Description
L/A	Link Status and Activity	Off	No link has been established between the port and the end node.
		Green	The port has established a link at 10 Gbps.
		Flashing green	Packets are being received or transmitted at 10 Gbps.

System Status LEDs

The system status LEDs on the front panel display general status information. To locate these LEDs, Figure 10.

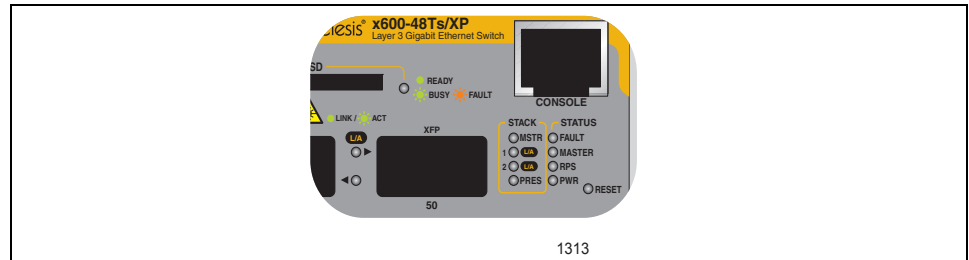

Figure 10. System Status LEDs

See Table 5 for a description of the System Status LEDs.

Table 5. System Status LEDs

LED	State	Description
FAULT	Off	Indicates normal operation.
	Red	Indicates a fault. The switch or the operating system software has malfunctioned. (Refer to Chapter 5, “Troubleshooting” on page 77 for instructions on how to troubleshoot a problem.)
MASTER	Off	Indicates that the switch is not the Stack Master.
	Flashing Green	Indicates the specific stack member’s ID of the switch in response to the ‘show stack indicator’ CLI command. The LED will repeatedly flash n times in quick succession, followed by a longer pause, where n is the stack member's ID.
	Green	Indicates that the switch is the Stack Master.
RPS	Off	No optional redundant power supply is connected to the switch.
	Green	An optional redundant power supply is physically connected to the switch and may be powered on or off.
POWER	Off	The switch is not receiving power.
	Green	The switch is receiving power.

Stack LEDs

The STACK LEDs reflect the status of the two Stack ports on the AT-StackXG Stacking Module. To locate the Stack LEDs, see Figure 11.

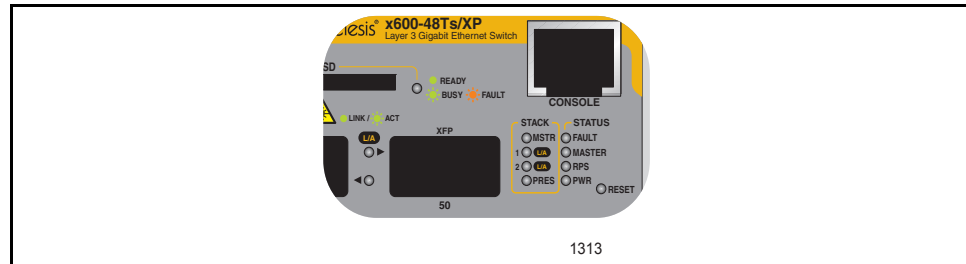

Figure 11. Stack LEDs

These LEDs remain off if the module is not installed. See Table 6 for a description of the STACK LEDs.

Table 6. STACK LEDs

LED	State	Description
MSTR	Off	The switch is not part of a stack or is a member unit of the stack.
	Green	The switch is the master unit of the stack.
1 L/A	Off	Stack Port 1 has not established a link to a stacking port on another AT-StackXG Stacking Module.
	Green	Stack Port 1 has established a link to a stacking port on another AT-StackXG Stacking Module.
	Flashing Green	Stack Port 1 has established a link to a stacking port on another AT-StackXG Stacking Module and is sending or receiving packet traffic.

Table 6. STACK LEDs

LED	State	Description
2 L/A	Off	Stack Port 2 has not established a link to a stacking port on another AT-StackXG Stacking Module.
	Green	Stack Port 2 has established a link to a stacking port on another AT-StackXG Stacking Module.
	Flashing Green	Stack Port 2 has established a link to a stacking port on another AT-StackXG Stacking Module and is sending or receiving packet traffic.
PRES	Off	The expansion slot for the AT-StackXG Stacking Module is empty.
	Green	The AT-StackXG Stacking Module is installed in the switch.

Both the x600-24Ts/XP and x600-48Ts/XP switches have one Secure Digital (SD) LED, defined in Table 7.

Table 7. Secure Digital LED

LED	Function	State	Description
SD	Link Status and Activity	Flashing amber	Indicates a fault has been detected. The SD card is not valid or a read or write procedure was unsuccessful.
		Green	An SD card has been detected.
		Flashing green	An SD card is reading or writing data. Do not eject the SD card when it is in this state.

Terminal Port

The terminal port is used to establish a local (out-of-band) management session with the switch. You establish a local management session by connecting a terminal or a personal computer with a terminal emulation program to the port.

The terminal port has an RJ-45 style connector. An RJ-45 to RS-232 management cable is supplied with the switch.

The terminal port is set to the following specifications:

- Default baud rate: 9600 bps (Range is 9600 to 115200 bps)
- Data bits: 8
- Parity: None
- Stop bits: 1
- Flow control: None

Note

These settings are for a DEC VT100 or ANSI terminal, or an equivalent terminal emulation program.

AT-RPS3204 Redundant Power Supply

The RPS connector on the rear panel of the switch connects to the optional AT-RPS3204 Redundant Power Supply module, shown in Figure 12. The unit can provide power to the switch in the event that the switch's internal power supply fails.

The AT-RPS3204 Redundant Power Supply module features one pre installed AT-PWR3202 Power Supply and three empty slots for additional power supplies. Each power supply can support one x600 switch. When fully populated with AT-PWR3202 Power Supplies, the AT-RPS3204 unit can support up to four x600 switches simultaneously.

The AT-RPS3204 Redundant Power Supply module is hot swappable with the x600 switches. This means that it is safe to connect a powered on AT-RPS3204 module to an x600 switch (which is also powered on) using a 21-pin D-combo connector cable from the module into the RPS connector on the x600 switch.

For information about installing an AT-RPS3204 unit, consult the documentation shipped with the unit.

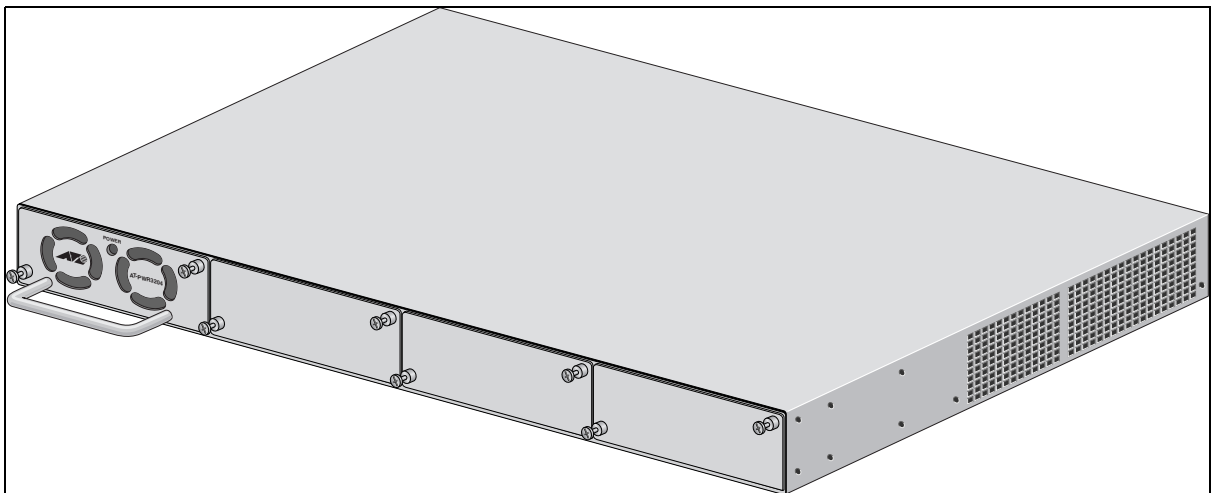

Figure 12. AT-RPS3204 Redundant Power Supply Unit

The pinouts for the redundant power supply's 21-pin D-combo port and connector are described in "RPS 21-pin D-combo Port and Connector Pinouts" on page 92.

AT-LBM (Loop Back) Module

The x600-48Ts/XP switch is shipped from the factory with an AT-LBM module installed in its expansion slot on the rear panel as shown in Figure 13. This module provides the capability for a full line rate, nonblocking switching configuration when there are connections on the x600-48Ts/XP switch to all 44 copper ports, two SFP ports, and two XFP ports.

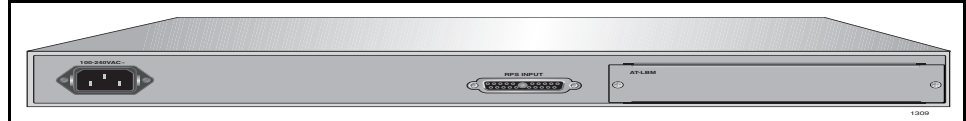

Figure 13. AT-LBM Module installed in x600-48Ts/XP Expansion Slot

Note

The x600-24Ts, x600-24Ts/XP, and x600-48Ts are all shipped from the factory with a blank panel installed in the expansion slot.

VCS Stacking Module

A Virtual Chassis Stack (VCS) is a group of x600 Layer 3 Gigabit Ethernet Series switches with a VCS Stacking module installed in each switch. This module with its two full-duplex, 12 Gbps stacking ports, unifies the individual switches into a single, logical unit so that the network operations of the devices encompass all of the Gigabit Ethernet ports. This can simplify network management and augment network bandwidth. Figure 14 shows the VCS Stacking Module (AT-StackXG).

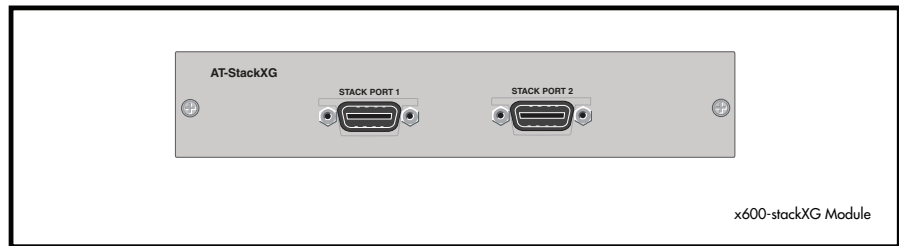

Figure 14. VCS Stacking Module (AT-StackXG)

Refer to “AT-StackXG Module Installation” on page 61 for the AT-StackXG module installation instructions. For further information on stacking, refer to the Allied Telesis Inc. website (www.alliedtelesis.com) for the *Overview of Virtual Chassis Stacking (VCS)* and the Virtual Chassis Stacking section of the *AW+ Software Reference for x600 Series Switches*.

AC Power Connector

The x600 switches have a single AC power supply socket on the rear panel, which has autoswitch AC inputs. To power the switch on or off, connect or disconnect the power cord.

Refer to “Technical Specifications” on page 87 for the input voltage range.

Chapter 2:

Virtual Chassis Stacking

This chapter contains the following sections:

- ❑ “VCStack™ Introduction” on page 40
- ❑ “Features of VCStacking” on page 40
- ❑ “The Physical Stack” on page 40
- ❑ “Resiliency Link” on page 42
- ❑ “VCStack Recovery States” on page 42
- ❑ “Resiliency Link Configurations via Switch Ports” on page 44
- ❑ “Resilient Stacked Topology” on page 45
- ❑ “Stack Formation” on page 46
- ❑ “The Role of the Stack Master” on page 46
- ❑ “Stack Member Failure and Recovery” on page 49
- ❑ “VCS Failure Recovery” on page 50
- ❑ “Stack Maintenance” on page 51

VCStack™ Introduction

A Virtual Chassis Stack (VCStack) is a group of physically separate switches that are connected so as to function as a single logical switch. In order to function as a VCStack, its component switches are connected using high-speed stacking links.

Switches must be of the same product type to exist within the same stack. The principles of product / stack compatibility is shown in the Table 8.

Table 8. Stacking Compatibility by Product Type

Product Types	x900-24XS, x900-24XT, x900-24XT-N	Via XEM-STK ports.
Product Type	x900-12XT/s	Via XEM-STK ports.
Product Type	SwitchBlade® x908	Via either XEM-STK ports, or high speed rear chassis ports.
Product Type	x600 (all variants)	Via AT-StackXG ports.

Features of VCStacking

Creating a VCStack (or VCS) greatly eases network management, because you can configure all the stacked devices via a single IP address. Creating a VCS will often eliminate your need to configure protocols such as VRRP and Spanning Tree. VCS also enables you to create highly resilient networks. This resiliency can be applied in several ways.

Within the stack itself, switch interconnection is via two links. The second link is able to provide an alternative data path, thus the stack will continue to function if a single link fails. Degraded performance might occur however, due to the reduced VCS bandwidth.

User ports can also be made extremely resilient by utilizing link aggregation. Aggregated links can span ports, modules, and even switches within the stack. Creating aggregated links that span multiple switches within a stack creates an extremely resilient configuration. Communication will still exist even if a switch and its aggregated ports fail.

The Physical Stack

A stack - depending on the switch types used - can comprise from 2 to 4 individual stack members interconnected via high speed stacking links. A stack always has a primary stack member called the **stack master**, and can contain up to 3 other stack members.

AT-StackXG Modules, Cables, and Connections

The stacks are connected via the stacking ports on the VCS Stacking Modules (AT-StackXG), which are installed in the back of each switch.

The following cables are used to connect the stacking ports of x600 series switches:

- ❑ High Speed Stacking Cables (0.5 meter) - StackXG/0.5
- ❑ High Speed Stacking Cables (1.0 meter) - StackXG/1

This configuration, shown in Figure 15, uses two switches that are connected back to back via two high-speed stacking links. Note that stacking ports labeled 1 must connect to stacking ports labeled 2. In this configuration the stack can still function using only a single high speed link.

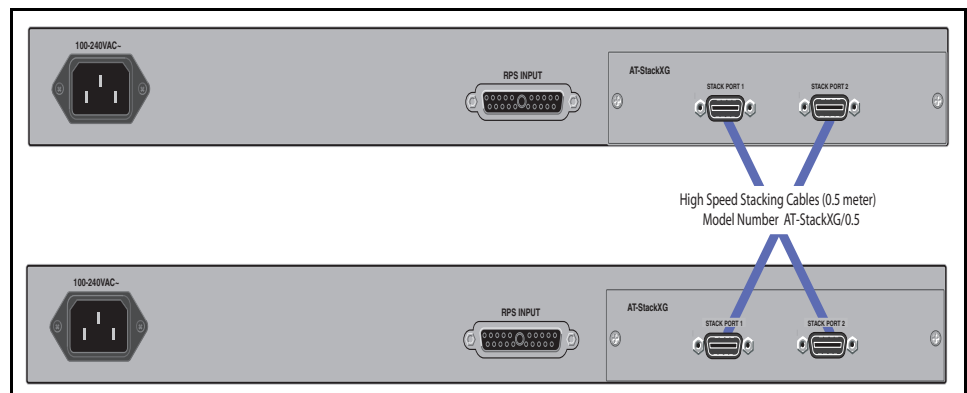

Figure 15. Back-to-Back Topology (x600 Switches)

Ring Configuration

A virtual stack using x600 switches can comprise up to 4 stack members connected in a ring topology. Figure 16 shows a ring comprising 3 stacked x600 series switches. Because an alternate path is provided between the stack members, this topology offers a very resilient configuration

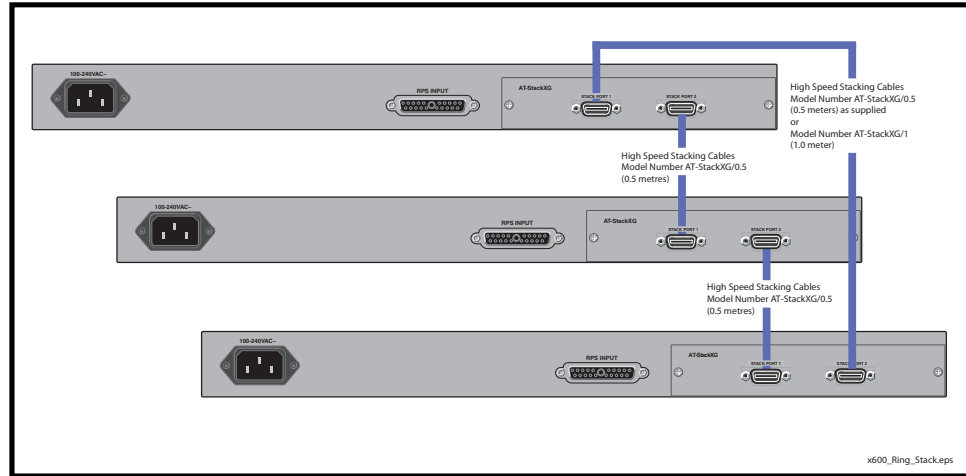

Figure 16. VCS Ring Topology Using x600 Switches

Resiliency Link Stack Resiliency Link

The purpose of the resiliency link is to provide the stack members with status information that enables them to detect whether the stack master is still operational after it has suffered either a power-down or software lock-up. This enables the other stack members to either operate in the fall-back mode, or to re-elect a new stack master. The state change table, Table 9, “State Change Table” on page 43 shows how the stack members respond to various problems occurring on the master node.

A resiliency link operates using a resiliency link VLAN to which resiliency link switch ports can become members.

VCStack Recovery States

The following state-change-table shows stack member failure conditions and recovery actions in situations where the resiliency link is present or absent.

Table 9. State Change Table

Event on Master Node	Reaction on Master	Reaction on Stack Member	Reaction on Stack Member
		With Resiliency Link	Without Resiliency Link
Both stack links removed	No change	Fallback action ¹	Re-elect master ²
XEM-STK Removed or Faulty	No change	Fallback action ¹	Re-elect master ²
Hardware reset (or fault)	Reset / offline	Re-elect master	Re-elect master ²
Run the <code>no stack enable</code> command ³	No change	Fallback action ¹	Not allowed Displays Error Message
Software application problem (lock-up or continual crashes)	Reboot as stack member	Re-elect master	Re-elect master
Software crash or lock-up	Frozen ⁴	Re-elect master	Re-elect master
Power-down or PSU failure	Powered down	Re-elect master	Re-elect master
Event on Stack Member Node	Reaction on Master	Reaction on Stack Member	Reaction on Stack Member
Both stack links removed	No change	Fallback action ¹	Re-elect master ²
XEM-STK removed or faulty	No change	Fallback action ¹	Re-elect master ²
Hardware reset (or fault)	No change	Reset/offline	Reset/offline
Run the <code>no stack enable</code> command ³	No change	Fallback action ¹	Fallback action ¹
Software application failover (lock-up or continual crashes)	No change	Re-boot as slave	Reboot as stack member
software crash or lock-up	No change	Frozen ⁴	Frozen ⁴
Power-down / PSU failure	No change	Powered Down	Powered down

1. The fallback action on a slave is first to run the fallback config script. Where there is no fallback script, the switch will disable all its switch ports.
2. The stack member assumes the role of stack master. In specific situations this condition could result in a stack containing two masters. This would present problems with network management and the control of links that were previously aggregated.
3. The following situation will apply to a switch that has been removed from the stack by the using the “no stack enable” command
 - a. The switch will be unaware of further faults within the stack it was previously a member of.
 - b. Should this switch then be powered down, all links previously shutdown (as a result of running the “no stack enable command”) will remain down.
4. If the slave’s ports are still up, this may cause downstream switches with trunked ports to operate incorrectly.

Resiliency Link Configurations via Switch Ports

Two resiliency-link configurations that connect to switch ports are shown below: Figure 17 shows the resiliency link connecting in a ring topology, whilst Figure 18 shows the resiliency link connecting to its switch ports via a network hub. In both configurations, the resiliency link connections are made using the ResiliencyLink VLAN and attaching the switch ports to the VLAN. For more information on using the resiliency link commands go to the Software Reference for the x600 Series Switches which can be found at www.alliedtelesis.com. The specific commands are the stack resiliencylink command on page 86.27 and the switchport resiliencylink command on page 86.30.

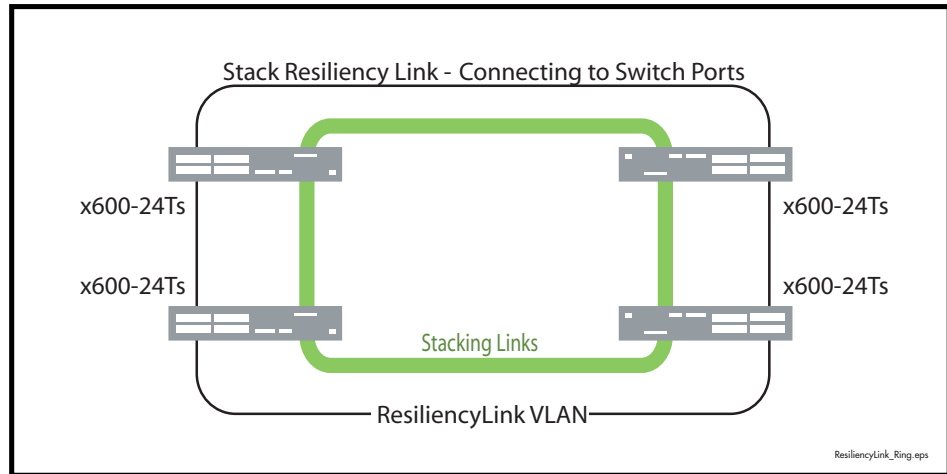

Figure 17. Resiliency link connecting to switch ports over the ResiliencyLink VLAN

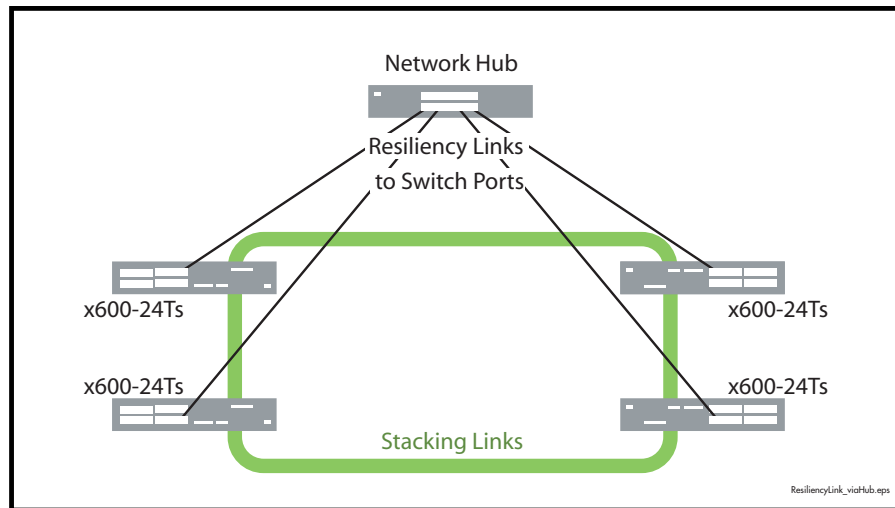

Figure 18. Resiliency link connecting to switch ports over the ResiliencyLink VLAN using a network hub

Resilient Stacked Topology

Where network connectivity uptime is a major criteria, you can use virtual chassis stacking to create highly reliable network configurations.

Employing link aggregation rather than spanning tree to manage the parallel paths, enables the bandwidth of both data links to be utilized under normal conditions, whilst enabling a single data link to operate should its partner link fail.

Stack Formation

A virtual chassis stack (VCS) always contains a master plus a number of stack members. To be part of a stack, a switch must connect to other potential stack members via dedicated stacking ports on the VCS Stacking module located in the rear of the switch. Figure 19 shows a stacking AT-StackXG module. Refer to “AT-StackXG Module Installation” on page 61 to install this module.

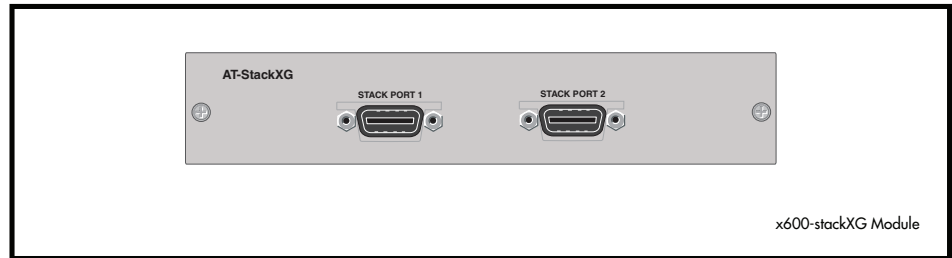

Figure 19. VCS Stacking Module

Once the switches have been physically connected to form a stack, powering all the members on automatically sets off a number of processes that enable the stack members to detect the presence of the other stack members and form themselves into a VCS.

The Role of the Stack Master

In addition to being a member of its VCS stack, the stack master manages functions such as software version control and distribution, routing processing, and network management.

Selecting the Stack Master

The stack members are able to automatically select which switch will become the stack master. This selection is based on two components:

1. The stack member's priority setting.
2. The stack member's MAC address.

For both components, the lower the number the higher the priority. To set the stack priority, run the stack priority command. Note that changes to these settings will not take effect until the next master re-election. To display these components run the show stack command.

The master is the switch with the lowest 'priority setting', or if no 'priority settings' are configured, the switch with the lowest MAC address will become the stack master. When a stack member is initially booted, its priority value defaults to 128. Therefore if all switches retain their defaults, then the stack master will be determined by MAC address comparison.

The stack also assigns a Stack Member-ID number to each member. This number provides a unique reference number for switches within the stack; it plays no part in selecting the stack master. The Stack Member-ID is the entity used as the first digit of the three component port identifier numbers. For example, port number 2.0.14 has the Stack Member-ID of 2.

Note

This last point is an important one to remember when using configuration scripts. You should ensure that you modify your configuration scripts to match any changes you have made to the Stack Member-ID assignments.

Note

The ability to independently set both a stack member's priority and its ID means that the stack master does not need to have an ID of 1; although configuration is simplified by arranging for ID 1 to be the device with the lowest priority value - and thereby forcing it to be the stack master. If you create a stack using new switches, the following (simplified) process should ensure that the master member has an ID of 1.

New switches are shipped with a Stack Member-ID of 1 and a priority of 128. If four such switches are created as a stack, the switch with the lowest MAC address will be selected to be the stack master (because all priority settings are 128). The remaining three stack member devices will then reboot and automatically be assigned IDs values of between 2 and 4. The stack master does not reboot and retains its Stack Member-ID of 1.

You can change the Stack Member-ID by using the stack renumber command.

Common Stack Configuration

Once the switches have configured themselves into a VCS stack, they all share the same configuration information and startup scripts.

Stack Management VLAN

Managing the stack is the same as managing an individual switch. You can connect to the asynchronous console port of any stack member, or you can set an IP address on a network VLAN (for example, VLAN1) and use SSH or Telnet for remote access.

As the switches form themselves into a stack, each switch creates a common stack management VLAN and a management IP address. Both the VLAN ID and the IP address are internal entities that are used between

the stacked switches, via the AT-StackXG interfaces, and therefore do not appear on the user network.

Initially the stack assigns the default VLAN tag ID of 4094 to the management VLAN, and assigns an IP address from the subnet 192.168.255.0 / 28 to this VLAN as the management IP address. Once the stack has formed, you can change both these settings. To change the VLAN ID use the stack management vlan command. To change the management IP address use the stack management subnet command. Note however, that you must keep the 28 bit subnet mask, (/28 or 255.255.255.240). Also note that because the stack's internal address mapping tables will register the management VLAN ID and the management IP address, these must be unique across the stack's internal and external network. To view the current settings for the stack management VLAN ID and IP address, use the show stack command

Stack Member Identification

When a switch becomes a member of a VCS Stack it is assigned a Stack Member-ID. Stack status information is displayed on the STACK LEDs shown on the switch's front panel shown in Figure 20. The following LEDs indicate the switch's status within the stack.

To observe the Stack Member-ID of the switch, you first run the show stack indicator command. Running this command causes the MASTER LED (located within the STATUS LED column) to initially turn off. A flash sequence then appears followed by a pause. The number of flashes within each sequence is the same as the Stack Member-ID of the switch. For example, if the switch had the Stack Member-ID 4, then the MASTER LED would flash 4 times followed by a pause, then 4 times again. Note that the MSTR LED that is located within the STACK LED column, does not perform this function.

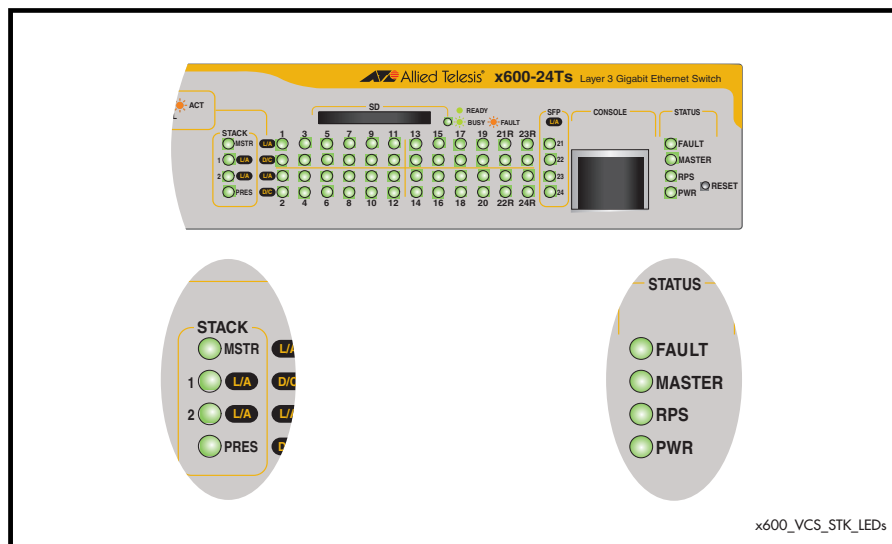

Figure 20. Stack and Status LEDs

Table 10. Stacking LED Functions

LED	State	Description
STACK LEDs		
MSTR	Green ON	The switch is the Stack Master.
	Green OFF	The switch is acting as a stack back-up member.
1- L/A	Green ON	Link on stacking port 1 is active.
	Green Flashing	Indicates traffic flowing through stacking port 1
	Green OFF	Link on stacking port 1 is inactive.
2- L/A	Green ON	Link on stacking port 2 is active.
	Green Flashing	Indicates traffic flowing through stacking port 2.
	Green OFF	Link on stacking port 2 is inactive.
PRES	Green ON	VCS Stacking Module (AT-StackXG) or Loopback Module (AT-LBM) has been inserted, i.e. is PRESENT.
STATUS LEDs		
MASTER	Green ON	The switch is the Stack Master.
	Green Flashing	When the show stack indicator command is activated, this LED will flash with a pattern that indicates the stack member ID of the switch.

Running QoS within a VCS stack

In general you can apply the same principles when configuring QoS on a VCS stack as you would for single switch; however there are a few specific changes that you will need to make. See the *AlliedWare Plus Software Reference* more information on this topic.

Stack Member Failure and Recovery

Management IP Addresses

A single virtual MAC address, from the current Master, will be used as the stack MAC address. If the stack master fails, the stack MAC address changes to reflect the new master's MAC address. If the stack MAC address does change, ARP tables of devices on the network will update to reflect the change in MAC address via *gratuitous ARP*.

VCS Failure Recovery

If the stack master either fails, or is removed, the other stack members will decide which of two actions to take.

1. Fallback action.
2. Re-elect a new stack master.

Note that a master fail-over will be slower than a stack member failure, and will require the restart (reconvergence) of routing protocols such as RIP.

Table 9, “State Change Table” on page 43 shows how the stack (non-master) members would respond to various problems occurring on the stack master stack.

Fallback Action

To initiate this action, the remaining stack members will disable all ports, then re-enable them using the fallback config file.

In order to provide an efficient alternative configuration, you should create a fallback config file that reflects the most appropriate working configuration for the failures that you feel are most likely to occur. One way to do this is to create a fall back file from your working system, then edit this file to provide an appropriate backup system configuration. See stack fallback-config command in the *AlliedWare Plus Software Reference*.

Re-elect New Stack Master

The stack members automatically determine which of them becomes the new VCS master.

Recombining Separated Stacks

When two separated stack units (stubs) are reconnected, a condition known as ‘*multiple master*’ will be detected. In this situation, a new VCS master is elected based upon the lowest Priority ID or (where both members have the same Priority ID) the lowest MAC address. The 'losing' master and the other prospective stack members will then reboot and join the new stack as ordinary stack members.

Stack Maintenance

Adding a Stack Member

An unstacked switch can be added to an existing stack (hot swapped in) with minimal impact on traffic. To do this, power down the new member switch, then connect its stacking ports and power on the switch. The switch will boot as a member of the stack.

Note

The existing Stack Member-ID and the device MAC address will have no effect on the status of the new member switch. The stack will admit the new device as ordinary stack member and allocate it a new Stack Member-ID if its ID is one that already exists.

However, for good practice we recommend pre-configuring the new member with settings that are appropriate for when the new switch becomes a stack member. This is to avoid unexpected situations occurring when the stack is rebooted. For example, if the new member had a priority setting that was lower than 128 and all the existing stack members were configured with the default; then, when the stack is rebooted, the new member would be elected as the stack master.

Replacing a Stack Member

A stack member can be removed from a stack (hot swap out) with minimal impact on stack traffic. To do this power-down the stack member, disconnect its AT-StackXG ports. Insert the new stack member, reconnect the stacking ports and power-up the new stack member.

You can seamlessly swap a stack member switch into the stack to replace another with the same configuration. This provides a simple way to replace an out of service switch with minimal impact, and minimal administration requirement. You should configure the replacement switch with the same member ID as its replacement prior to its insertion into the stack.

Repairing a Broken Stub

Stack stubs occur when a fault results in stack splitting into two, with one of the stack members takes on the role of stack master. Where (unknown to some of the stack members) the master is still active, the result can be two independently operating stacks. These are termed stubs.

When two stub stacks are reconnected, a dual master situation will be detected, and the console log will display the message, 'duplicate master' was detected. This situation results in the re-election of the stack master. The losing master will return to being a stack member.

Chapter 3

Installing the Hardware

This chapter provides procedures to install an x600 switch. The chapter contains the following sections:

- ❑ “Reviewing Safety Precautions” on page 54
- ❑ “Unpacking a Switch” on page 56
- ❑ “Installing the Power Cord Retaining Clip” on page 57
- ❑ “Installing the Switches in an Equipment Rack” on page 58
- ❑ “Resetting the Switch” on page 60
- ❑ “AT-StackXG Module Installation” on page 61

Reviewing Safety Precautions

Please review the following safety precautions before you begin to install the switches or any of their components.

Note

The  indicates that a translation of the safety statement is available in a PDF document titled “Translated Safety Statements” (613-000990) posted on the Allied Telesis website at www.alliedtelesis.com.



Warning: Class 1 Laser product.  L1



Warning: Do not stare into the laser beam.  L2



Warning: To prevent electric shock, do not remove the cover. No user-serviceable parts inside. This unit contains hazardous voltages and should only be opened by a trained and qualified technician. To avoid the possibility of electric shock, disconnect electric power to the product before connecting or disconnecting the LAN cables.  E1





Warning: Do not work on equipment or cables during periods of lightning activity.  E2



Warning: Power cord is used as a disconnection device. To de-energize equipment, disconnect the power cord.  E3



Warning: Class I Equipment. This equipment must be earthed. The power plug must be connected to a properly wired earth ground socket outlet. An improperly wired socket outlet could place hazardous voltages on accessible metal parts.  E4

Pluggable Equipment. The socket outlet shall be installed near the equipment and shall be easily accessible.  E5



Caution: Air vents must not be blocked and must have free access to the room ambient air for cooling.  E6

Warning: Operating Temperature. This product is designed for a maximum ambient temperature of 40° degrees C.  E7

All Countries: Install product in accordance with local and National Electrical Codes. *↪* E8

Circuit Overloading: Consideration should be given to the connection of the equipment to the supply circuit and the effect that overloading of circuits might have on overcurrent protection and supply wiring. Appropriate consideration of equipment nameplate ratings should be used when addressing this concern. *↪* E21

Caution: Risk of explosion if battery is replaced by an incorrect type. Replace only with the same or equivalent type recommended by the manufacturer. Dispose of used batteries according to the manufacturer's instructions.

Attention: Le remplacement de la batterie par une batterie de type incorrect peut provoquer un danger d'explosion. La remplacer uniquement par une batterie du même type ou de type équivalent recommandée par le constructeur. Les batteries doivent être éliminées conformément aux instructions du constructeur. *↪* E22



Warning: Mounting of the equipment in the rack should be such that a hazardous condition is not created due to uneven mechanical loading. *↪* E25

If installed in a closed or multi-unit rack assembly, the operating ambient temperature of the rack environment may be greater than the room ambient temperature. Therefore, consideration should be given to installing the equipment in an environment compatible with the manufacturer's maximum rated ambient temperature (T_{mra}). *↪* E35

Caution: Installation of the equipment in a rack should be such that the amount of air flow required for safe operation of the equipment is not compromised. *↪* E36



Warning: Reliable earthing of rack-mounted equipment should be maintained. Particular attention should be given to supply connections other than direct connections to the branch circuits (e.g., use of power strips). *↪* E37

Unpacking a Switch

To unpack a switch, perform the following procedure:

1. Remove all components from the shipping packages.

Note

Store the packaging material in a safe location. You must use the original shipping material if you need to return the unit to Allied Telesis.

2. Place the switch on a level, secure surface.
3. Make sure the following components are included in your switch package. If any item is missing or damaged, contact your Allied Telesis sales representative for assistance.
 - One x600 Series Layer 3 Gigabit Ethernet Switch
 - Two rack-mount brackets
 - Eight flathead Phillips rack-mount bracket screws
 - AC power cord (Americas, Australia, EU, Japan, and UK only)
 - AC power cord retaining clip
 - Management cable for local management

Installing the Power Cord Retaining Clip

Perform the following procedure to install the power cord retaining clip on the switches:

1. Locate the power cord retaining clip, shown in Figure 21.

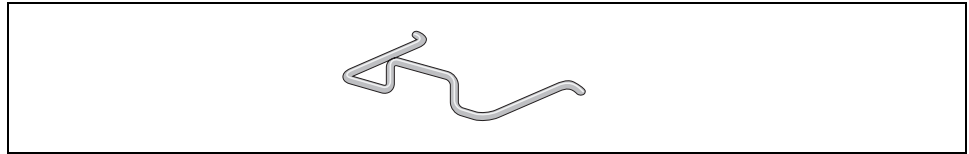

Figure 21. Power Cord Retaining Clip

2. Install the clip on the AC power connector on the rear panel of the switch. With the “u” of the clip facing down, press the sides of the clip toward the center and insert the short ends into the holes in the retaining bracket, as shown in Figure 22.

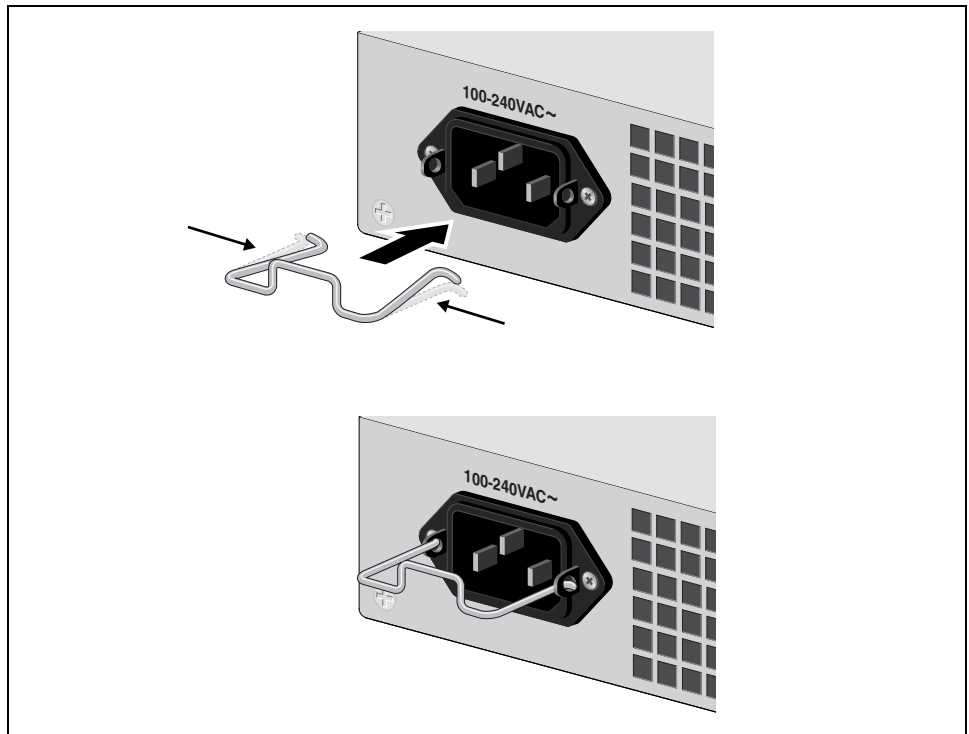

Figure 22. Inserting the Retaining Clip into the Retaining Bracket

You are now ready to install the switches in the equipment rack, as explained in the next procedure.

Installing the Switches in an Equipment Rack

Perform the following procedure to install each switch in a standard 19-inch rack:

Note

Steps 1, 2, and 3 are optional. These steps provide instructions on how to remove the snap-on plastic feet from the bottom of a switch. You can leave the feet on.

1. Place the switch upside down on a level, secure surface.
2. Using a flat-head screwdriver, remove the snap-on plastic feet from the bottom of the switch, as shown in Figure 23.

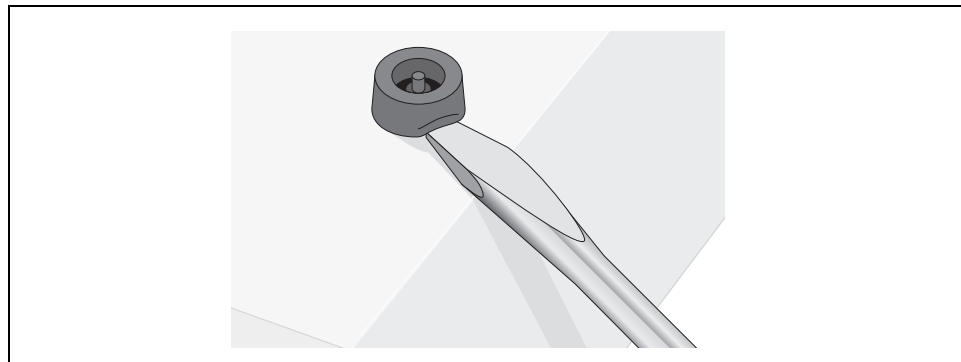

Figure 23. Removing the Feet

3. Turn the switch over.
4. Attach a rack-mount bracket to one side of the switch using four of the screws that come with the switch, as shown in Figure 24.

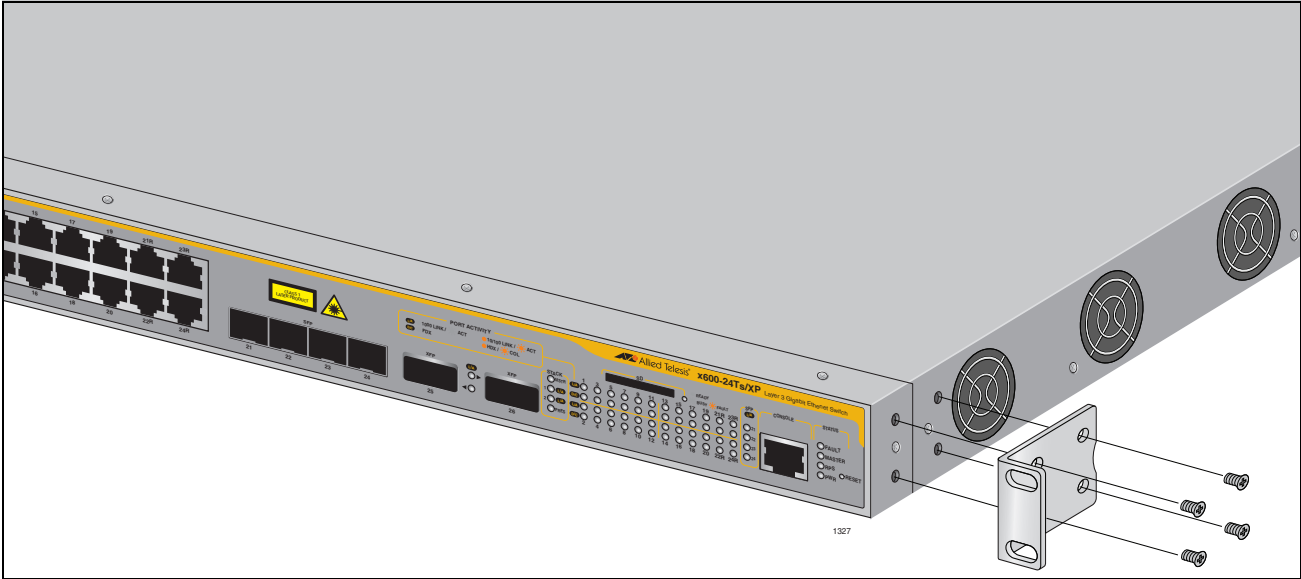

Figure 24. Attaching Rack-Mount Brackets

- 5. Install the second rack-mount bracket on the other side of the switch with the four remaining screws.
- 6. Mount the switch in a 19-inch rack using standard screws (not provided), as shown in Figure 25.

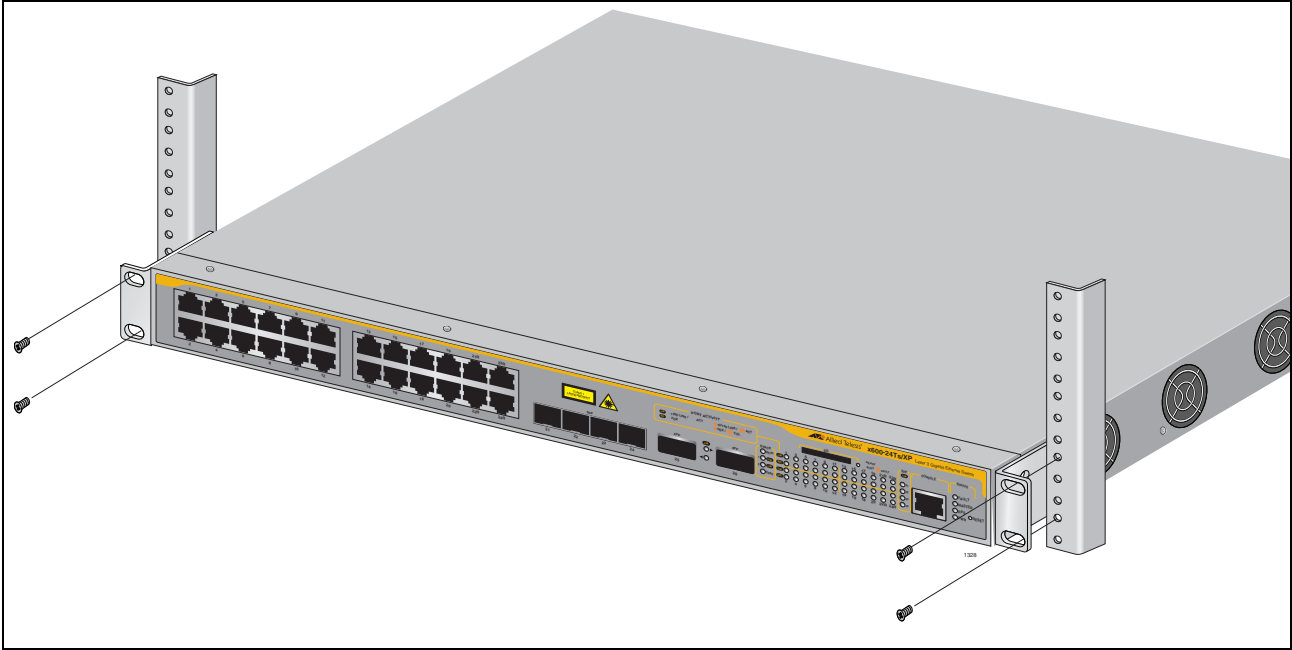

Figure 25. Mounting the Switch in a Rack

Resetting the Switch

You may need to reset the switch after upgrading the firmware or after you have made a configuration change that requires resetting the switch to activate the change.

To reset the x600 switch, perform the following procedure:

1. Locate the RESET button which is on the right hand side of the faceplate.
2. Press the RESET button with the tip of a pen or a similar nonconducting object as shown in Figure 26.



Figure 26. Resetting the Switch

AT-StackXG Module Installation

Overview A Virtual Chassis Stack (VCS) is a group of x600 Layer 3 Gigabit Ethernet Series switches with a VCS Stacking module installed in each switch. This module with its two full-duplex, 12 Gbps stacking ports, unifies the individual switches into a single, logical unit so that the network operations of the devices encompass all of the Gigabit Ethernet ports. This can simplify network management and augment network bandwidth. Figure 14 shows the VCS Stacking Module (AT-StackXG).

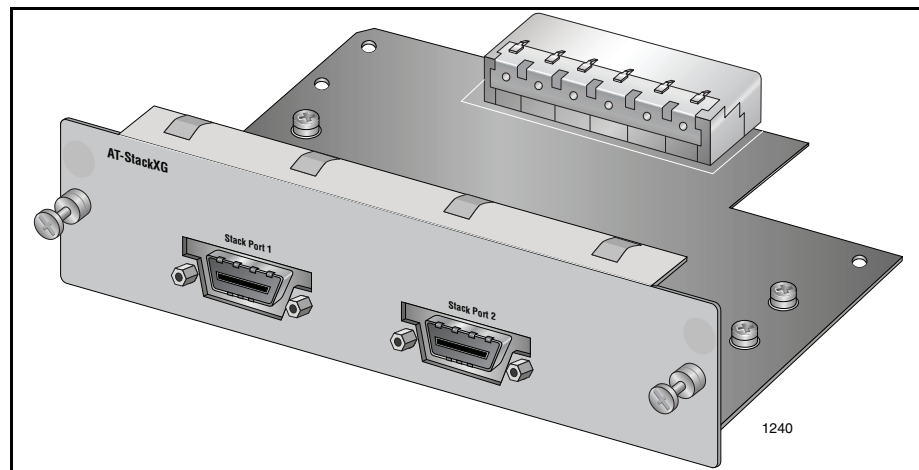

Figure 27. AT-StackXG Module

Preparation Review the following information before installing the AT-StackXG Stacking Module:

- The AT-StackXG Stacking Module is hardware hot-swappable. You can install or replace the module while the switch is powered on.



Caution

If the stacking module is added or replaced in an operating stack, the stack topology may change and cause the stack to reboot and interrupt network traffic.

- The AT-StackXG module is supported in all x600 series products.
- Do not install AT-StackXG module until you have read the latest version of the AW+ Software Release Notes and the x600 Series product documentation.
- Support for the AT-StackXG module requires software version 5.3.1 or later of *AlliedWare Plus Operating System Software*.

Installing the AT-StackXG Module

To install the AT-StackXG module, perform the following procedure:

1. Remove the module from the shipping package.

Note

Store the packaging material in a safe location. You must use the original shipping material if you need to return the unit to Allied Telesis.

2. Remove the blank panel from the expansion slot on the rear panel of the switch by loosening the two captive screws on the panel with a cross-head screwdriver.

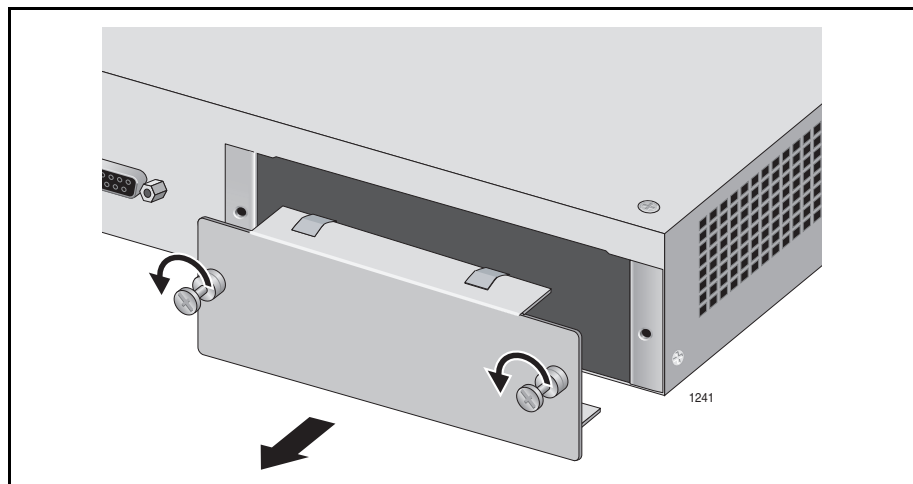

Figure 28. Removing the Blank Panel from the Expansion Slot

Note

All X600 Series Layer 3 Switch models are shipped from the factory with a Blank Panel installed in the rear panel Expansion Slot except for the x600-48Ts/XP, which is shipped with an AT-LBM (Loop Back) module instead.

Note

Do not remove the blank panel from the chassis until you are ready to install a module. An open slot allows dust to enter the unit and reduces proper airflow and cooling.

3. Align the edges of AT-StackXG module with the guides in the slot and carefully slide the module into the chassis until it is flush with the rear panel of the chassis, as shown in Figure 29. Light pressure may be needed to seat the module on the connector on the rear panel of the chassis.



Caution

Do not force AT-StackXG module into place. Doing so may damage the connector pins on the backplane inside the chassis. If there is resistance, remove the module and reinsert it after verifying that the edges of the card are properly aligned in the guides in the chassis' module slot.

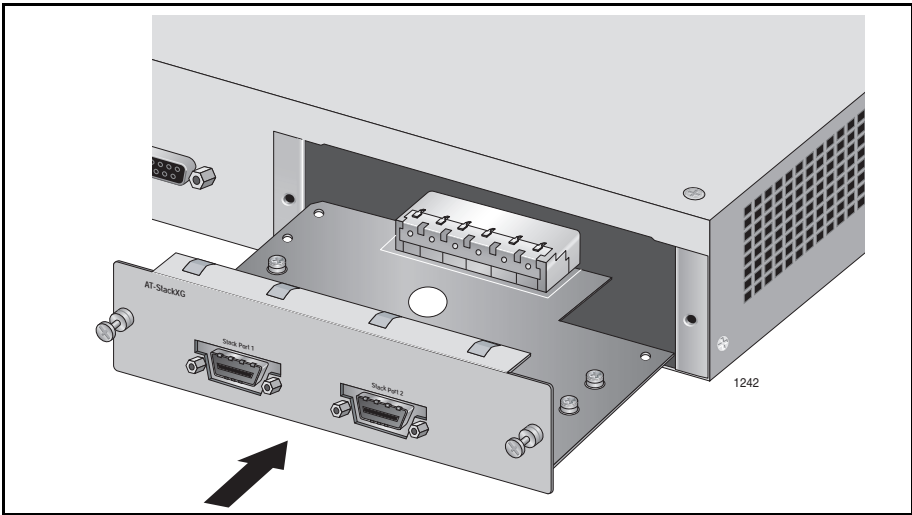

Figure 29. Installing the AT-StackXG Stacking Module

- 4. Secure AT-StackXG module to the chassis by tightening the two captive screws with a cross-head screwdriver.

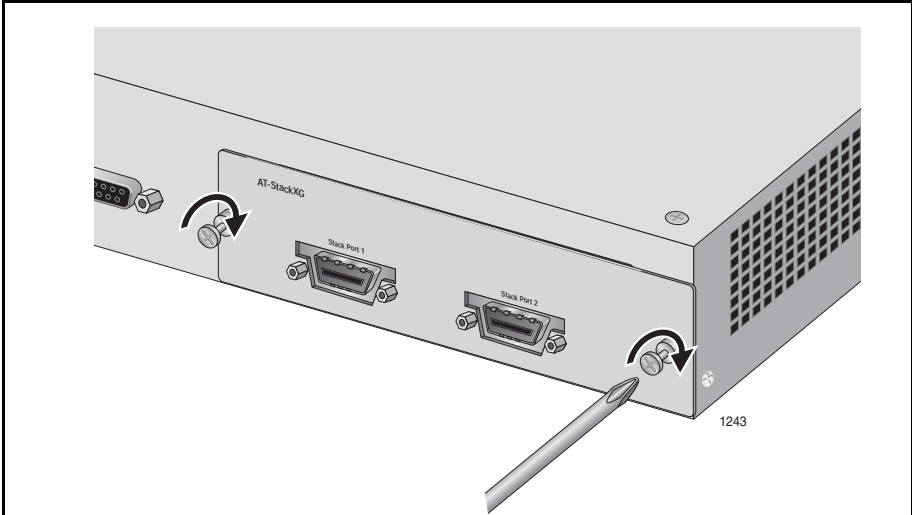

Figure 30. Securing the AT-StackXG Stacking Module

Note

Do not cable AT-StackXG module until you have prepared the switch's *AlliedWare Plus Operating System* software on the x600 Series Switches as explained in the *x600 series AlliedWare Plus 5.3.1 Software Reference*.

5. Remove the plastic protector from the connector at one end of the stacking cable.

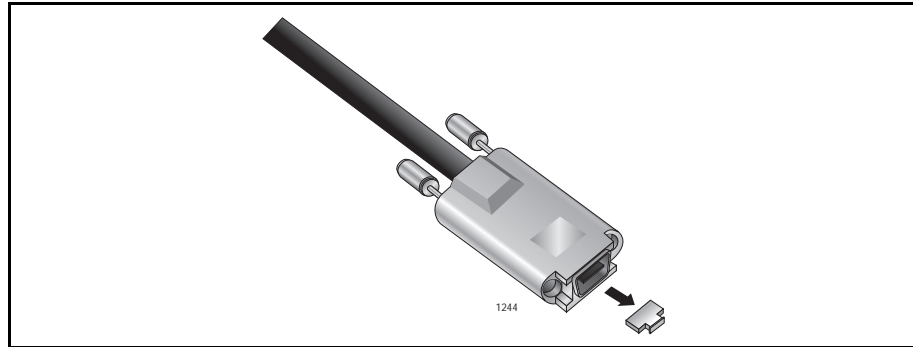

Figure 31. Removing the Plastic Protector

6. Connect the cable to either Stack Port 1 or Stack Port 2 on the stacking module and secure by tightening the two captive thumbscrews.
7. Remove the plastic protector from the connector at the other end of the stacking cable and connect it to a Stack Port on the stacking module in the next switch of the stack. A stacking cable must crossover and connect to a different port on the next stacking module. Stack Port 1 on a module must connect to Stack Port 2 on the next module. Do not connect two Stack Port 1 ports or Stack Port 2 ports together.

Chapter 4

Cabling the Network Ports

This chapter contains the instructions for attaching network cables to an x600 switch. The chapter contains the following sections:

- ❑ “Twisted Pair and Fiber Optic Cable Specifications” on page 66
- ❑ “Installing SFP/XFP Transceivers” on page 68
- ❑ “Cabling the Twisted Pair and Fiber Optic Ports” on page 73
- ❑ “Powering on a Switch” on page 74
- ❑ “Warranty Registration” on page 76

Twisted Pair and Fiber Optic Cable Specifications

Twisted Pair Cable Specifications

Table 11 lists the cabling specifications for the 10/100/1000Base-T twisted pair ports.

Table 11. Twisted Pair Cabling and Distances

Speed	Cable Type	Maximum Operating Distance
10 Mbps	Standard TIA/EIA 568-B-compliant Category 3 or better shielded or unshielded cabling with 100 ohm impedance and have a frequency range that extends to 16 MHz.	100 m (328 ft)
100 Mbps	Standard TIA/EIA 568-A-compliant Category 5 or TIA/EIA 568-B-compliant Enhanced Category 5 (Cat 5e) shielded or unshielded cabling with 100 ohm impedance and have a frequency range that extends to 100 MHz.	100 m (328 ft)
1000 Mbps	Standard TIA/EIA 568-A-compliant Category 5 or TIA/EIA 568-B-compliant Enhanced Category 5 (Cat 5e) shielded or unshielded cabling with 100 ohm impedance and have a frequency range that extends to 100 MHz.	100 m (328 ft)

Note

The auto-MDI/MDI-X feature on the twisted pair ports automatically configures the MDI/MDI-X setting when a link is established with an end node. Available when a port is at the default setting of Auto-Negotiation, this feature allows you to use a straight-through twisted pair cable when connecting any type of network device to a port.

Disabling Auto-Negotiation on a port and setting the speed and duplex mode manually also disables the auto-MDI/MDI-X feature. A port where Auto-Negotiation has been disabled defaults to MDI-X. Disabling Auto-Negotiation may require manually configuring a port's MDI/MDI-X setting or using a crossover cable.

**SFP/XFP
Transceiver
Cable
Specifications**

The cable specifications for an optional SFP or XFP transceiver can be found in the transceiver's installation guide that is shipped with the device.

Installing SFP/XFP Transceivers

Review the following guidelines before installing an optional SFP or XFP transceiver in a switch:

- ❑ A transceiver can be hot-swapped; the switch can be powered on when you install it. However, you should always disconnect the cables first before removing a transceiver.
- ❑ You must install the transceiver before you connect the cables to it.
- ❑ Fiber optic transceivers are dust sensitive. When a fiber optic cable is not installed, or when you store the transceiver, always keep the plug in the optical bores. When you do remove the plug, keep it for future use.
- ❑ Unnecessary removal and insertion of a transceiver can lead to premature failure.



Warning

A transceiver can be damaged by static electricity. Be sure to observe all standard electrostatic discharge (ESD) precautions, such as wearing an antistatic wrist strap, to avoid damaging the device.

Installing an SFP Transceiver

To install an SFP transceiver in an x600 switch, perform the following procedure:

1. Remove the dust plug from a transceiver slot on the switch, as shown in Figure 32.

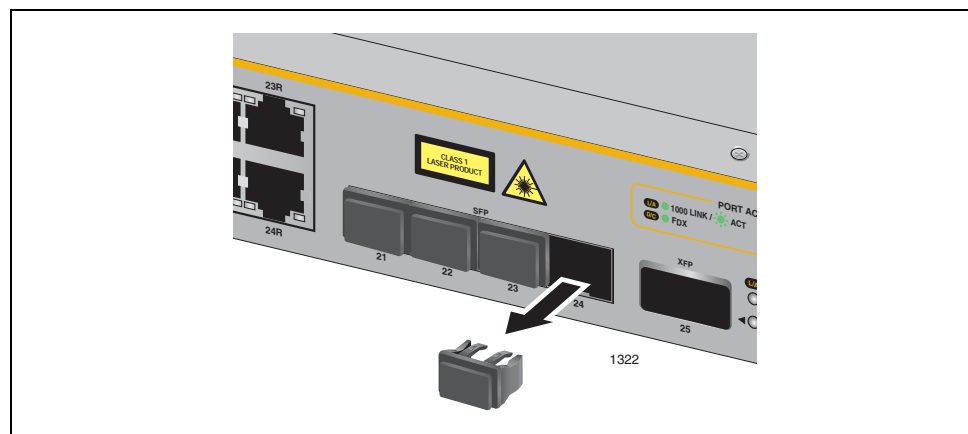

Figure 32. Removing a Dust Plug from an SFP Slot

2. Remove the transceiver from its shipping container and store the packaging material in a safe location.

- 3. Position the transceiver with the label facing up.
- 4. Slide the transceiver into the slot until it clicks into place.

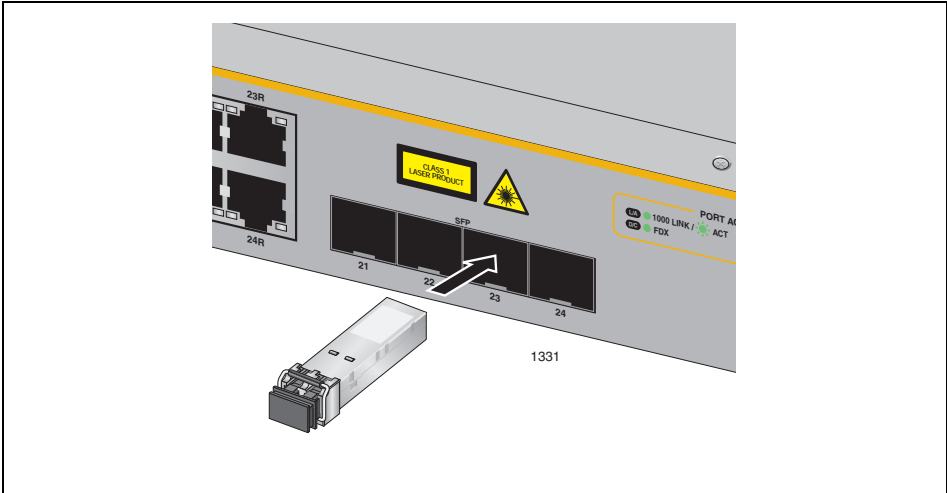

Figure 33. Installing an SFP Transceiver

- 5. For the x600-24Ts and x600-24Ts/XP switches, verify that the handle on the SFP transceiver is in the upright position, as shown in Figure 34, to prevent inadvertently removing the transceiver.

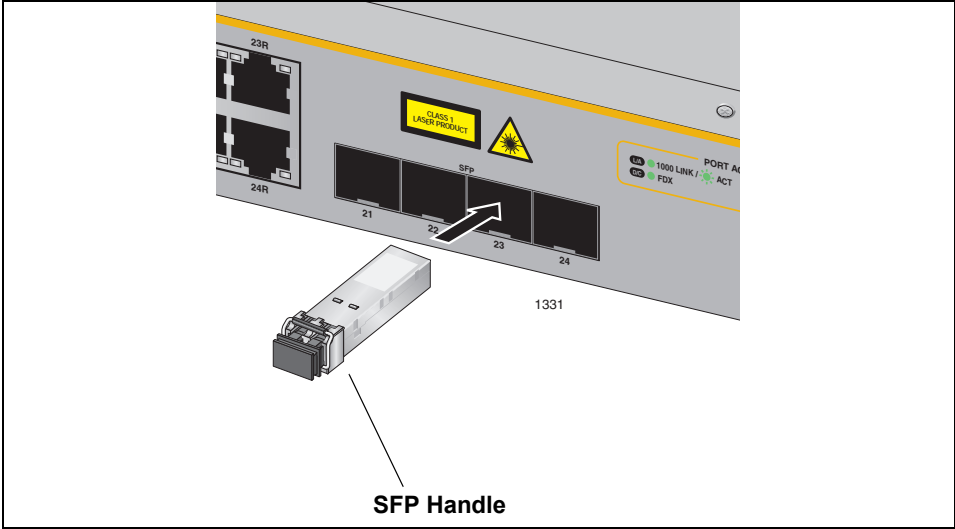

Figure 34. Positioning Handles on the x600-24Ts and x600-24Ts/XP Switches

6. For the x600-48Ts and x600-48Ts/XP switches, verify that handles on the top two SFP modules are in the up position and the bottom two SFP modules are in the down position as show in Figure 35.

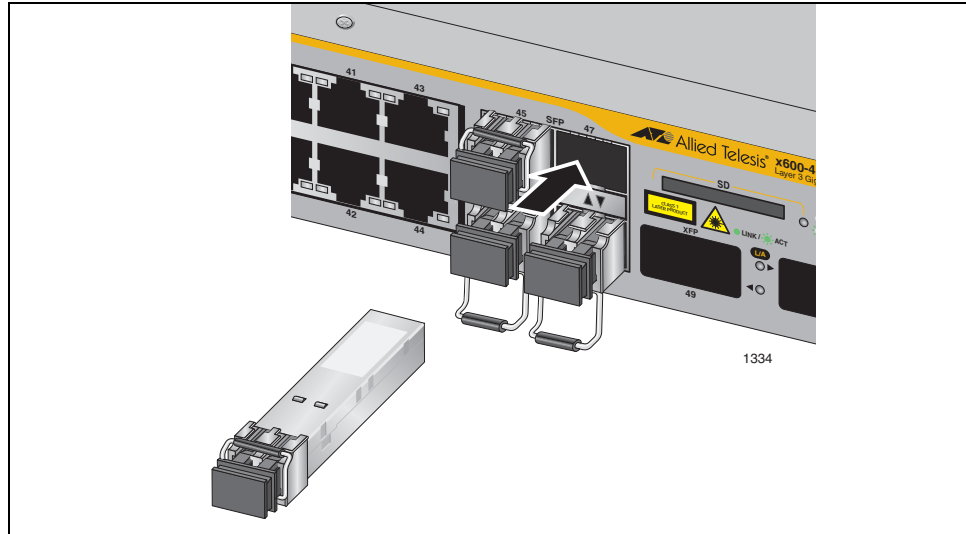

Figure 35. Positioning SFP Handles on the x600-48Ts and x600-48Ts/XP Switches

7. Repeat this procedure to install another SFP transceiver or go to “Cabling the Twisted Pair and Fiber Optic Ports” on page 73.

For SFP optical and cabling specifications, consult the documentation shipped with the module.

Installing an XFP Transceiver

To install an XFP transceiver in an x600 switch, perform the following procedure:

1. Remove the dust plug from a transceiver slot on the switch. Refer to Figure 36.

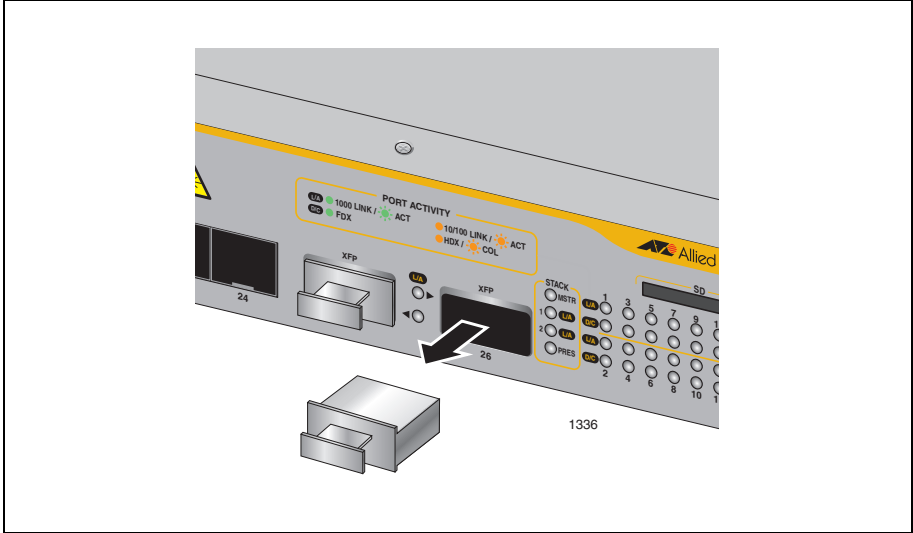

Figure 36. Removing an XFP Dust Plug

2. Remove the transceiver from its shipping container and store the packaging material in a safe location.
3. Position the transceiver with the label facing down.
4. Slide the transceiver into the slot until it clicks into place.

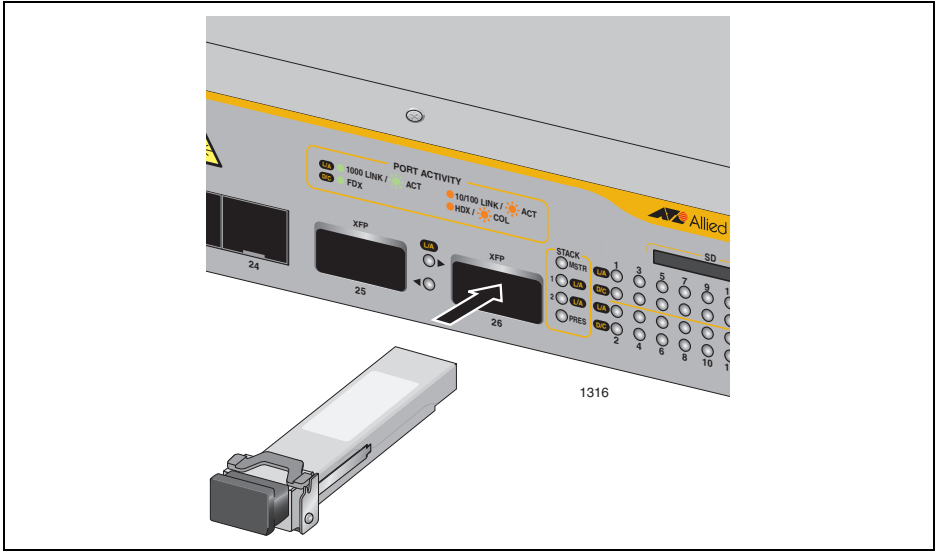

Figure 37. Installing an XFP Transceiver

5. Repeat this procedure to install a second XFP transceiver or go to “Cabling the Twisted Pair and Fiber Optic Ports” on page 73.

For XFP optical and cabling specifications, consult the documentation shipped with the module.

Cabling the Twisted Pair and Fiber Optic Ports

Observe the following guidelines when connecting a twisted pair or fiber optic cable to a port on the switch:

- ❑ The connector on the cable should fit snugly into the port on the switch. The tab on the connector should lock the connector into place.
- ❑ Because the twisted pair ports on the switch are auto-MDI/MDI-X, any type of network device can be connected to a port on the switch using a straight-through twisted pair cable. If you disable Auto-Negotiation on the port, the port defaults to MDI-X.
- ❑ If your network topology contains a loop where two or more network devices can communicate with each other over more than one network path, make sure that your switch is properly configured with the appropriate protocol(s); i.e., STP, ESPR, LACP, etc. Data loops without these protocols enabled can adversely affect network performance.
- ❑ In order for a switch port to successfully Auto-Negotiate its duplex mode with an end node, the end node should also be using Auto-Negotiation. Otherwise, a duplex mode mismatch can occur. A switch port using Auto-Negotiation defaults to half-duplex if it detects that the end node is not using Auto-Negotiation. This can result in a mismatch if the end node is operating at a fixed duplex mode of full-duplex.

To avoid this problem, disable Auto-Negotiation on a switch port and set the port's speed and duplex mode manually if the end node has a fixed duplex mode of full-duplex.

Powering on a Switch

To power on a switch, perform the following procedure:

1. Position the power cord retaining clip in the up position, as shown in Figure 38.

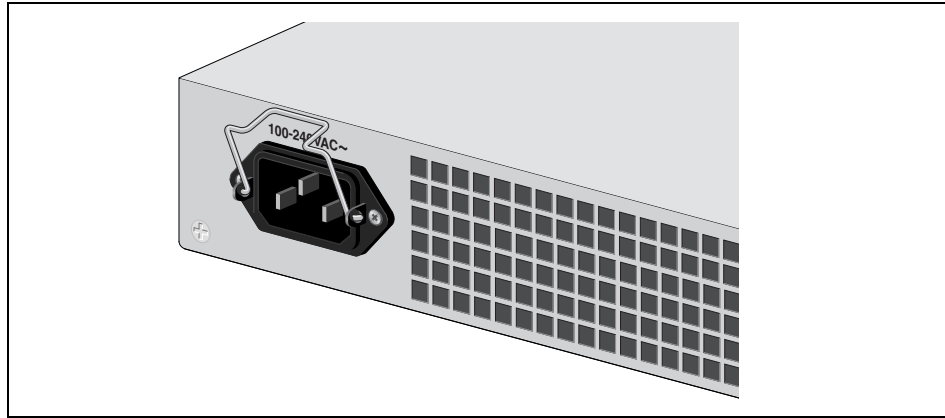

Figure 38. Power Cord Retaining Clip in the Up Position

2. Plug the power cord into the AC power connector on the rear panel of the unit (see Figure 39).



Warning: Power cord is used as a disconnection device. To de-energize equipment, disconnect the power cord. ⚡ E3

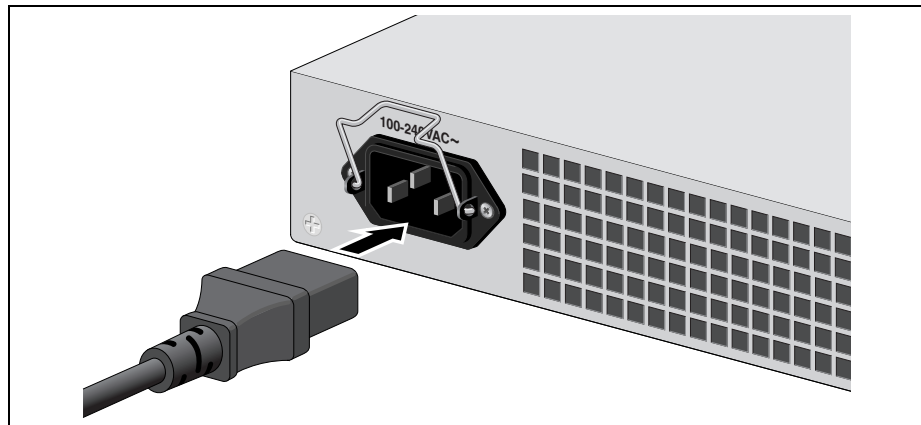

Figure 39. Connecting the AC Power Cord

3. Connect the other end of the power cord to an appropriate AC power outlet. For power specifications for the switch, refer to “Power Specifications” on page 88.

4. Start a local management session on the unit by performing the next procedure.

Starting a Local Management Session

The following procedure describes how to connect an RJ-45 cable to an x600 switch. For information about how to log onto the AlliedPlus™ Operating System Software, see the *AlliedWare Plus Operating System Software Reference Guide*.

To start a local management session on the unit, perform the following procedure:

1. Connect the RJ-45 end of the management cable included with the x600 switch to the Terminal Port on the front panel of the switch, as shown in Figure 40.

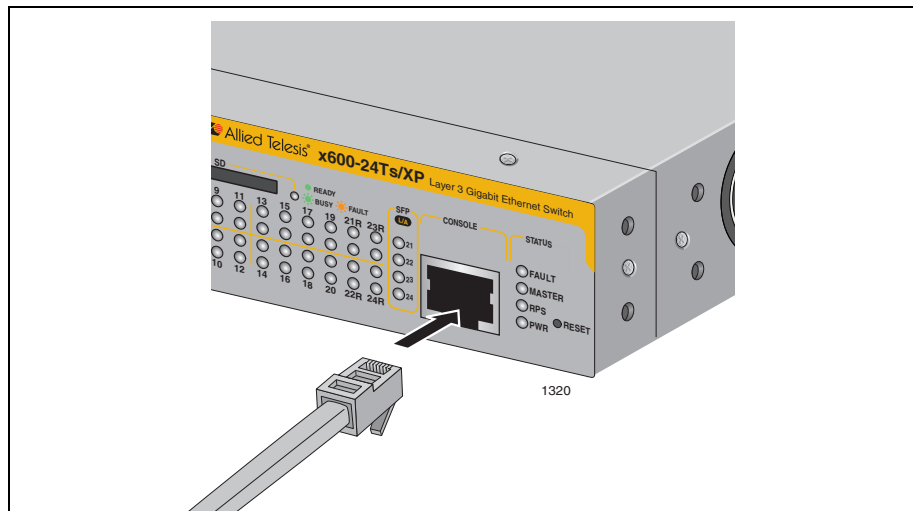

Figure 40. Connecting the Management Cable to the RJ-45 Terminal Port on the Switch

2. Connect the other end of the cable to an RS-232 port on a terminal or a personal computer with a terminal emulation program.
3. Configure the terminal or terminal emulation program as follows:
 - Baud rate: Default is 9600 bps (Range is 9600 to 115200 bps)
 - Data bits: 8
 - Parity: None
 - Stop bits: 1
 - Flow control: None

Note

The port settings are for a DEC VT100 or ANSI terminal, or an equivalent terminal emulator program.

Warranty Registration

For warranty information and registration, go to the Allied Telesis web site at www.alliedtelesis.com/warranty.

Chapter 5

Troubleshooting

This chapter contains information about how to troubleshoot a switch in the event a problem occurs. Sections in the chapter include:

- ❑ “Power LED is Off” on page 78
- ❑ “Twisted Pair Port Link LED is Off” on page 79
- ❑ “SFP or XFP LED is Off” on page 80
- ❑ “Transceiver is Installed but the Status is “Not Present”” on page 81
- ❑ “System Fault LED is Blinking” on page 82
- ❑ “System Fault LED is Steadily On” on page 83
- ❑ “Cannot Establish a Local (Out-of-Band) Management Session” on page 84
- ❑ “Switch Functions Intermittently” on page 85
- ❑ “Issues with Virtual Stacking Chassis Configuration” on page 86

Note

If you are unable to resolve the problem after following the instructions in this chapter, contact Allied Telesis Technical Support for assistance. Refer to “Contacting Allied Telesis” on page 8 for contact information.

Power LED is Off

Check the PWR LED on the front of the switch. If the LED is off, indicating that the unit is not receiving power, do the following:

- ❑ Make sure the power cord is securely connected to the power source and to the AC connector on the rear panel of the switch.
- ❑ Verify that the power outlet has power by connecting another device to it.
- ❑ Connect the unit to another power source.
- ❑ Use a different power cord.
- ❑ Check that the voltage from the power source is within the required levels for your region.

Twisted Pair Port Link LED is Off

When a twisted pair port on the switch is connected to a properly operating end node, the Link LED for the port should be on. If a Link LED is off, do the following:

Note

A 1000Base-T connection can take from five to ten seconds to establish a link.

- ❑ Verify that the end node connected to the port is powered ON and is operating properly.
- ❑ Check that the twisted pair cable is securely connected to the port on the switch and to the port on the end node.
- ❑ Make sure that the twisted pair cable does not exceed 100m (328 ft).
- ❑ Verify that you are using the appropriate category of twisted pair cable. For information, refer to Table 11 on page 66.
- ❑ Determine if a crossover cable is required. Since the twisted pair ports feature auto MDI/MDI-X, you should be able to use a straight-through cable regardless of the type of device you connect to a port. However, if you disable Auto-Negotiation on a port and set a port's speed and duplex mode manually, the port defaults to MDI-X. Disabling Auto-Negotiation may require manually configuring a port's MDI/MDI-X setting or using a crossover cable.
- ❑ Make sure that the operating parameters of a port on the switch are compatible with the end node to which the port is connected. This may require using the switch's operating system software.
- ❑ For a switch port to successfully Auto-Negotiate its duplex mode with an end node, the end node should also be using Auto-Negotiation. Otherwise, a duplex mode mismatch can occur. A switch port using Auto-Negotiation defaults to half-duplex if it detects that the end node is not using Auto-Negotiation. This can result in a mismatch if the end node is operating at a fixed duplex mode of full-duplex.

To avoid this problem, disable Auto-Negotiation on a switch port and set the port's speed and duplex mode manually if the end node has a fixed duplex mode of full-duplex.

- ❑ The switch has a bad cable detection feature that enables it to determine if a twisted pair cable has a electrical short that might cause a network loop. If the switch detects a bad cable on a port, it does not establish a link on that port. In this situation, replace the cable.

SFP or XFP LED is Off

When a fiber optic port on the switch is connected to a properly operating end node, the Link LED for the port should be on. If a Link LED is off, do the following:

- ❑ Verify that the end node connected to the port is powered ON and is operating properly.
- ❑ Check that the fiber optic cable is securely connected to the port on the switch and the port on the end node.
- ❑ If the fiber optic port is on a SFP or XFP transceiver, check that the transceiver is firmly inserted into the slot on the switch.
- ❑ Make sure that you are using the appropriate type of fiber optic cable and that the cable length does not exceed the allowed maximum distance. For cable specifications for an SFP transceiver, refer to the installation instructions shipped with the module.
- ❑ Use a fiber optic tester to test the attenuation on the cable and the strength of the optical signal. For operating specifications for an SFP transceiver, refer to the installation instructions shipped with the module.
- ❑ Check that the operating specifications (for instance, wavelength and maximum operating distance) of the fiber optic port on the remote end node are compatible with the fiber optic port on the switch.
- ❑ Check that the fiber optic ports on the switch and on the end node are operating at the same speed and duplex mode.
- ❑ A fiber optic cable contains two separate fiber strands. One strand is for receiving data and the other is for transmitting data. When you connect a fiber optic cable to a port, be sure that the receive fiber connector is connected to the transmit connector on the remote end node. In addition, check that the transmit fiber connector is connected to the receive connector on the remote node.

Note

The L/A LED for an SFP transceiver slot may remain ON if you remove the transceiver when it has a link to an end node without first disconnecting the fiber optic cable. The L/A LED will change to OFF the next time an SFP module is installed in the slot. To avoid this, always disconnect the fiber optic cable before removing a transceiver.

Transceiver is Installed but the Status is “Not Present”

If a SFP or XFP transceiver is installed in a transceiver slot but the Uplink Information menu in the AlliedWare Plus Operating System Software interface displays “Not Present” for that port, do the following:

- ❑ Verify that the transceiver is completely inserted in the slot on the front of the switch.

Note

The uplink status does not reflect whether a fiber optic cable is connected to the transceiver.

System Fault LED is Blinking

A blinking FAULT LED indicates that the switch is updating the active boot configuration file or a new version of the operating system software is in the process of being downloaded to the switch. The LED stops blinking after the switch has completed updating the boot configuration file or downloading the operating system software.

System Fault LED is Steadily On

If the system FAULT LED is steadily on, a problem has occurred in the switch. Do the following:

- ❑ Reset the switch by disconnecting and reconnecting the AC power cord.
- ❑ If the FAULT LED remains ON, download a new version of the switch's operating system software. For instructions, refer to the *AlliedWare Plus Operating System Software Reference Guide*.

Note

If the FAULT LED remains steadily on, contact Allied Telesis Technical Support for assistance. See "Contacting Allied Telesis" on page 8.

Cannot Establish a Local (Out-of-Band) Management Session

If you are unable to establish a local (out-of-band) management session with the switch through the terminal port on the front panel, do the following:

- ❑ Check that the RJ-45 serial management cable is securely connected to the serial terminal port on the switch and to the RS-232 port on the terminal or personal computer.
- ❑ Check that the operating parameters on the terminal or the terminal emulation program have been set correctly. The default settings for the RJ-45 serial terminal port can be found in “Starting a Local Management Session” on page 75.

Switch Functions Intermittently

If a switch functions intermittently, check the system hardware status through the management interface:

- ❑ Note the current voltage for the power supply compared to the optimum rating.
- ❑ Verify that the system temperature is within the operating range.

Issues with Virtual Stacking Chassis Configuration

For information on issues with stacking, refer to the Allied Telesis Inc. website (www.alliedtelesis.com) for the *Overview of Virtual Chassis Stacking (VCS)* and the Virtual Chassis Stacking section of the *AW+ Software Reference for x600 Series Switches*.

Appendix A

Technical Specifications

Physical Specifications

Dimensions (H x W x D):

x600-24Ts	44 mm x 440 mm x 305 mm (1.72 in. x 17.34 in. x 12.0 in.)
x600-24Ts/XP	44 mm x 440 mm x 305 mm (1.72 in. x 17.34 in. x 12.0 in.)
x600-48Ts	44 mm x 440 mm x 305 mm (1.72 in. x 17.34 in. x 12.0 in.)
x600-48Ts/XP	44 mm x 440 mm x 305 mm (1.72 in. x 17.34 in. x 12.0 in.)

Weight:

x600/24Ts	3.86 kg (8.50 lb.)
x600-24Ts/XP	4.35 kg (9.60 lb.)
x600-48Ts	4.88 kg (10.75 lb.)
x600-48Ts/XP	4.90 kg (10.80 lb.)

Recommended Minimum Ventilation on All Sides:	100 mm (4.0 in)
--	-----------------

Environmental Specifications

Operating Temperature:	0° C to 40° C (32° F to 104° F)
Storage Temperature:	-25° C to 70° C (-13° F to 158° F)
Operating Humidity:	5% to 90% noncondensing
Storage Humidity:	5% to 95% noncondensing
Maximum Operating Altitude:	3,048 m (10,000 ft)
Maximum Nonoperating Altitude:	4,000 m (13,100 ft)

Power Specifications

Maximum Power Consumption:

x600-24Ts	76 watts
x600-24Ts/XP	76 watts
x600-48Ts	123 watts
x600-48Ts/XP	123 watts

Input Voltage:

AC	100-240V AC, 2.0 A maximum, 50/60 Hz
----	--------------------------------------

Certifications

EMI (Emissions):	FCC Class A, ICES-003 Class A, EN55022 Class A, EN61000-3-2, EN61000-3-3, VCCI Class A, C-TICK, CE
EMC (Immunity):	EN55024
Electrical and Laser Safety:	EN60950-1 (TUV), EN60825-1 (TUV), UL 60950-1 (CULUS), CSA-C22-2 No. 60950-1 (CULUS)
Quality and Reliability (MTBF):	x600-24Ts 130,000 hrs. x600-24Ts/XP 130,000 hrs. x600-48Ts 90,000 hrs. x600-48Ts/XP 90,000 hrs.
Compliance Marks:	CE, CULUS, TUV, C-Tick

RJ-45 Twisted Pair Port Pinouts

Figure 41 illustrates the pin layout of an RJ-45 connector and port.

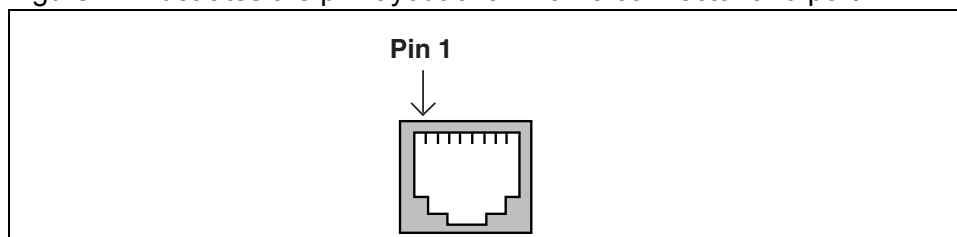

Figure 41. RJ-45 Connector and Port Pin Layout

Table 12 lists the pin signals when a port is operating in the MDI configuration at 10 or 100 Mbps.

Table 12. MDI Pin Signals - 10 or 100 Mbps

Pin	Signal
1	TX+
2	TX-
3	RX+
6	RX-

Table 13 lists the pin signals when a port is operating in the MDI-X configuration at 10 or 100 Mbps.

Table 13. MDI-X Pin Signals - 10 or 100 Mbps

Pin	Signal
1	RX+
2	RX-
3	TX+
6	TX-

The MDI/MDI-X setting is established automatically when a port is set to Auto-Negotiation. If a port's speed and duplex are set manually, the MDI/MDI-X setting defaults to the MDI-X setting.

Table 14 lists the pin signals when a port operating at 1000 Mbps.

Table 14. Pin Signals - 1000 Mbps

Pinout	Pair
1	Pair 1 +
2	Pair 1 -
3	Pair 2 +
4	Pair 3 +
5	Pair 3 -
6	Pair 2 -
7	Pair 4 +
8	Pair 4 -

RJ-45 Style Serial Terminal Port Pinouts

Table 15 lists the pin signals on the RJ-45 style serial terminal port.

Table 15. RJ-45 Style Serial Terminal Port Pin Signals

Pin	Signal
4	Data Carrier Detect
3	Transmit Data
6	Receive Data
7	Data Set Ready
5	Ground
2	Data Terminal Ready
8	Clear to Send
1	Request to Send

RPS 21-pin D-combo Port and Connector Pinouts

Figure 42 illustrates the pin layout of the RPS 21-pin D-combo port and connector.

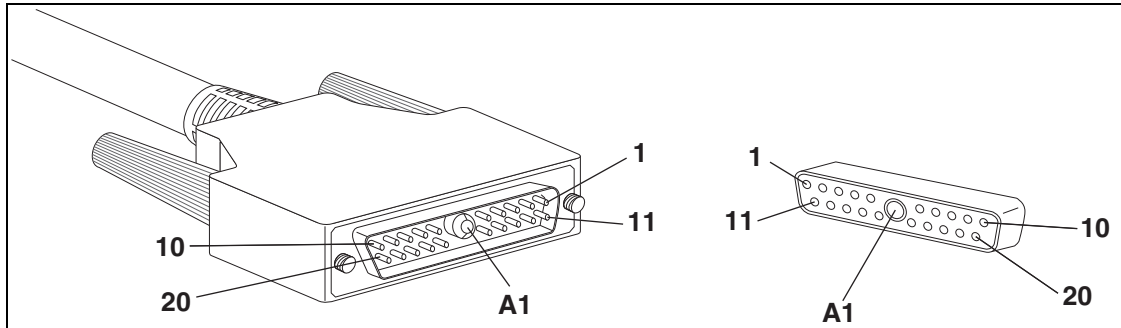

Figure 42. RPS 21-pin D-combo Connector and Port Pin Layout

Table 16 lists the definitions for the RPS 21-pin D-combo port and connector pins.

Table 16. RPS 21-pin Connector Pin Definitions

Pin	Definition
1	Power supply ID
2	Fan 2 status
3	Fan 1 status
4	RPS status
5	Ground
6	Ground
7	RPS status
8	+12.0 VDC sense
9	Primary 12V
10	No connect
11	Ground
12	Ground
13	Ground
14	Ground
15	Ground

Table 16. RPS 21-pin Connector Pin Definitions (Continued)

Pin	Definition
16	Ground
17	Ground
18	+12.0 VDC sense
19	Ground
20	No connect
A-1	+12.0 VDC

